

# E-box Remote

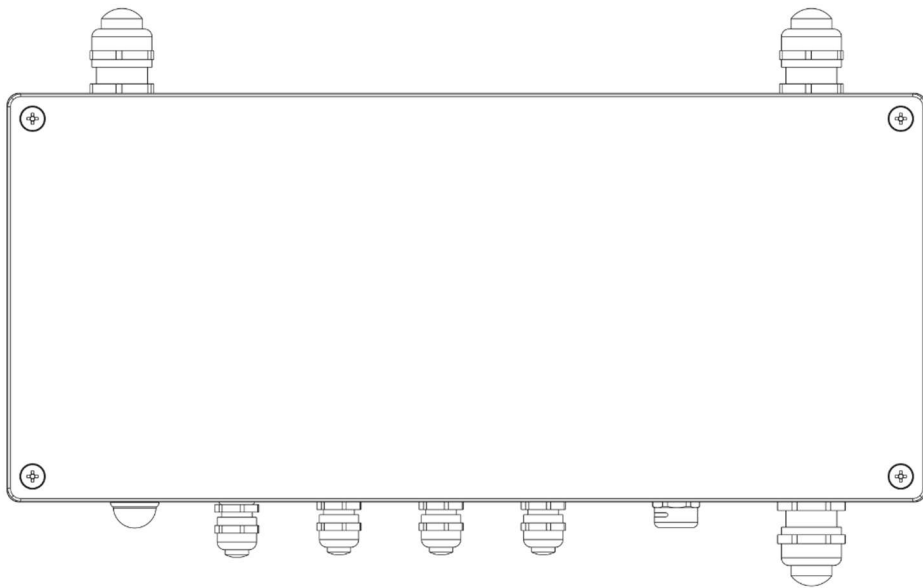

QR code for user manual



# E-box Remote

## Table of contents

<b>1. Safety information</b> .....	<b>3</b>
<b>2. Fixture description</b> .....	<b>5</b>
<b>3. Mounting</b> .....	<b>7</b>
<b>4. Eminere Remote modes</b> .....	<b>10</b>
<b>5. E-box Remote menu</b> .....	<b>16</b>
5.1 DMX Addr .....	16
5.2 Info .....	16
5.3 Personality .....	17
5.4 Special settings .....	18
<b>6. Robe Ethernet Access Portal (REAP)</b> .....	<b>19</b>
6.1 Settings on computer .....	19
6.2 Settings on fixtures.....	19
6.3. REAP menu screens .....	19
6.4 Status screen .....	19
6.5 Personality screen.....	20
6.6 Devices screen.....	20
6.7 Settings screen.....	21
<b>7. Software update</b> .....	<b>22</b>
<b>8. Technical specifications</b> .....	<b>26</b>
<b>9. Disposing of the product</b> .....	<b>27</b>
<b>10. Change Log</b> .....	<b>27</b>

# 1. Safety information

**FOR YOUR OWN SAFETY, PLEASE READ THIS USER MANUAL CAREFULLY  
BEFORE POWERING OR INSTALLING YOUR E-box Remote!  
Save it for future reference.**

## **DANGEROUS VOLTAGE CONSTITUTING A RISK OF ELECTRIC SHOCK IS PRESENT WITHIN THIS UNIT!**

Make sure that the available voltage is not higher than stated on the fixture. Always disconnect the fixture from AC power before removing its cover.

Do not install the fixture near an open flame.

This fixture falls under protection class I. Therefore, this fixture has to be connected to a mains socket outlet with a protective earthing connection.

Do not connect this fixture to a dimmer pack.

Do not cover the fixture with cloth or other materials.

The fixture was designed for outdoor use, and it is intended for professional application only. It is not for household use.

When choosing the installation spot, please make sure that the fixture is not exposed to extreme heat or dust.

Only operate the fixture after having checked that the housing is firmly closed, and all screws are tightly fastened.

Operate the fixture only after having familiarized yourself with its functions. Do not permit operation by persons not qualified to operate the fixture. Most damages are the result of unprofessional operation!

Please consider that unauthorized modifications on the fixture are forbidden due to safety reasons! Please use the original packaging if the fixture is to be transported.

If this device will be operated in any way different to the one described in this manual, the product may suffer damages and the warranty becomes void. Furthermore, any other operation may lead to dangers like short-circuit, burns, electric shock etc.

The product (covers and cables) must not be exposed to a high frequency electromagnetic field higher than 3V/m.

Immunity of the equipment is designed according to the standard EN 55035 Electromagnetic compatibility of multimedia equipment - Immunity requirements

Emission of the equipment complies with the standard EN55032 Electromagnetic compatibility of multimedia equipment – Emission Requirements according to class B.

This device complies with part 15 of the FCC Rules. Operation is subject to the following two conditions: (1) This device may not cause harmful interference, and (2) this device must accept any interference received, including interference that may cause undesired operation.

Changes or modifications not expressly approved by the party responsible for compliance could void the user's authority to operate the equipment.

The [Device] wireless operation is safe and complies to RF Exposure requirements.

This equipment has been tested and found to comply with the limits for a Class B digital device, pursuant to part 15 of the FCC Rules. These limits are designed to provide reasonable protection against harmful interference in a residential installation. This equipment generates, uses and can radiate radio frequency energy and, if not installed and used in accordance with the instructions, may cause harmful interference to radio communications. However, there is no guarantee that interference will not occur in a particular installation. If this equipment does cause harmful interference to radio or television reception, which can be determined by turning the equipment off and on, the user is encouraged to try to correct the interference by one or more of the following measures:

- Reorient or relocate the receiving antenna.
- Increase the separation between the equipment and receiver.

- Connect the equipment into an outlet on a circuit different from that to which the receiver is connected.
- Consult the dealer or an experienced radio/TV technician for help.

**ATTENTION!**  
**Risque de choc. Couper L'alimentation avant L'entretien.**  
**Non destine a à un usage domestique**

Convient aux emplacements mouillés.

Ce produit doit être installé selon le code d'installation pertinent, par une personne qui connaît bien le produit et son fonctionnement ainsi que les risques inhérents.

## 2. Fixture description

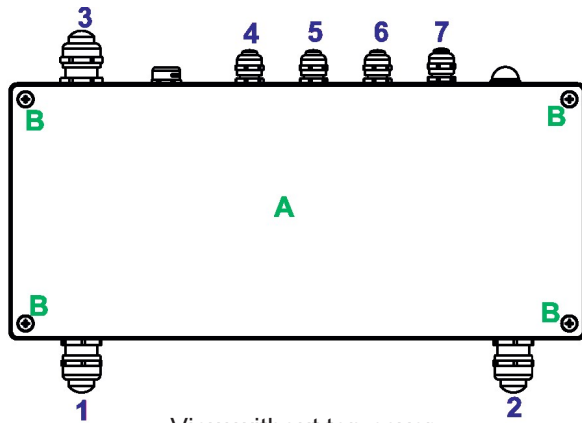

View without top cover

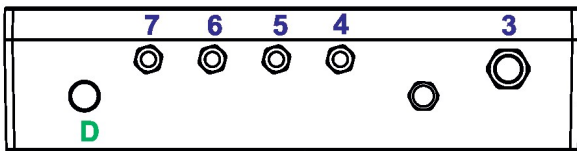
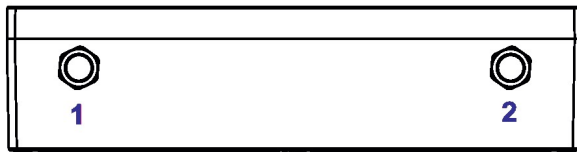
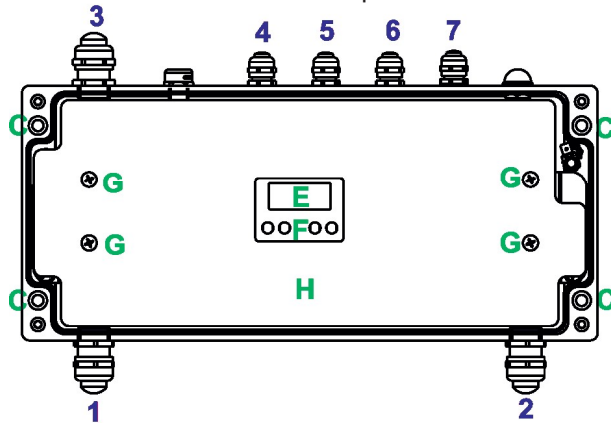

- A - Top cover
- B - Top cover screws
- C - Mounting holes
- D - Antenna cover
- E - Display
- F - Control buttons
- G - Screws of terminal blocks cover
- H - Terminal blocks cover

- 1 - LED Output 1 (cable gland M20x1.5)
- 2 - LED Output 2 (cable gland M20x1.5)
- 3 - Power IN (cable gland M20x1.5)
- 4 - DMX OUT (cable gland M12x1.5)
- 5 - DMX IN (cable gland M12x1.5)
- 6 - Ethernet OUT (cable gland M12x1.5)
- 7 - Ethernet IN (cable gland M12x1.5)

Connection points on DPS RB4175

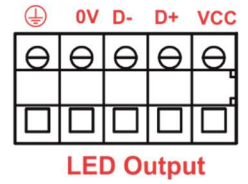
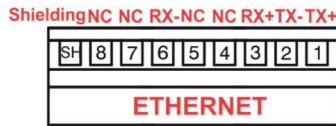
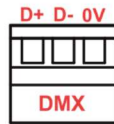
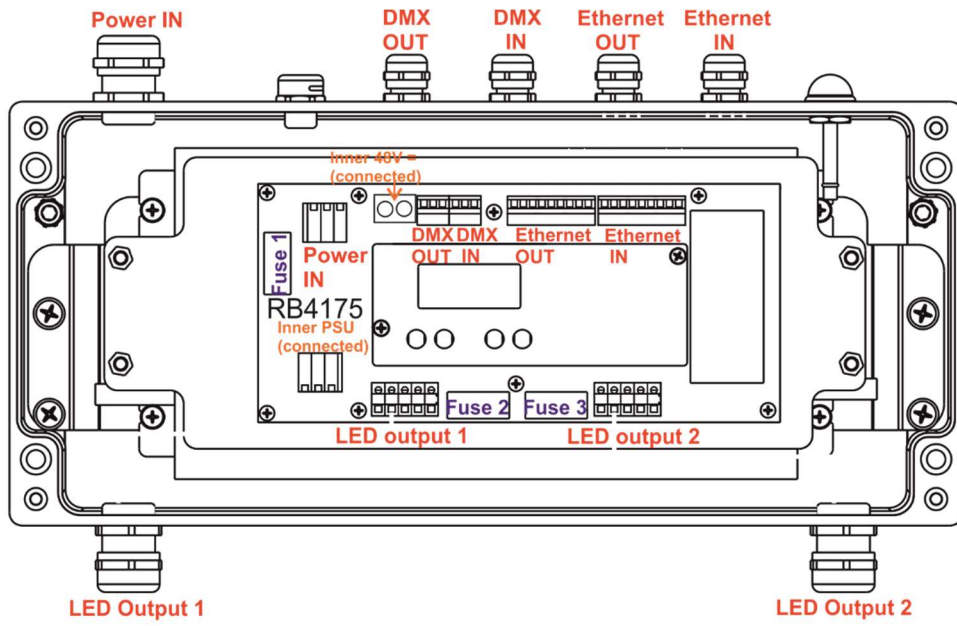

### 3. Mounting

**Fixture must be installed by a qualified electrician in accordance with all national and local electrical and construction codes and regulations.**

**Setting and addressing the E-box Remote without top cover can be done by a qualified person only!**



**Note for cable glands.**

We recommend applying an adequate layer of the paste LOCTITE 5331 on the plastic holder of the cable gland before inserting it into the body of the gland.

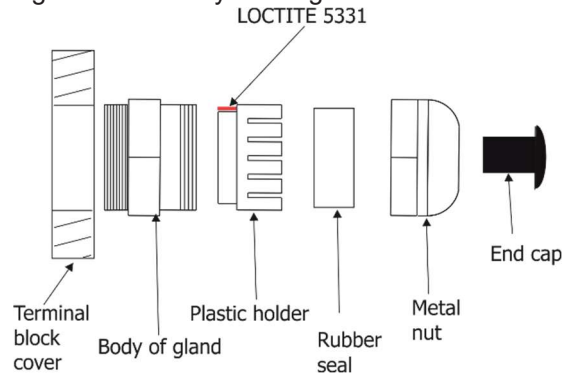

1. Remove the top cover (A) from the E-box Remote by unscrewing four fastening screws (B) in order to get access to the display (E), control buttons (F).
2. Fasten the E-box Remote on a non-flammable flat surface via four mounting holes (C) of a diameter of 7 mm in its housing.
3. Remove the terminal blocks cover (H) from the E-box Remote by unscrewing four fastening screws (G) in order to get access to the terminal blocks.
4. Remove end caps from cable glands before passing cables. To keep declared IP rating of the device, every cable gland has to be covered with the end cap if the cable gland is not used.

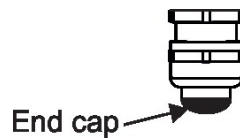

5. Pass cables for DMX and Ethernet through cable glands M12x1.5 and connect them to the terminal blocks and tighten the cables in the cable glands.
6. Pass cables for Power and LED outputs through cable glands M20x1.5 and connect them to the terminal blocks and tighten the cables in the cable glands.  
 Cable glands serve for cables of the following diameters:  
Cable gland M12x1.5 (DMX IN/OUT, Ethernet IN/OUT) - for cable of a diameter of 3-7mm.  
Cable gland M20x1.5 (Power IN, LED Output) - for cable of a diameter of 7-13mm. For smaller diameter of cable (4-8mm) you have to remove original seal from the cable gland M20 and use the reducing seal (P/N 13051388) instead of it. Reducing seals are enclosed to the product.  
 Check that all screws and cable glands are firmly tightened.
7. Screw the terminal blocks cover (H) back to the E-box Remote.
8. Connect the E-box Remote to mains.
9. Set the E-box Remote by means of the control panel (E) and buttons (F).
10. Disconnect the E-box Remote from mains and screw the cover (A) back on the box.

**ALWAYS DISCONNECT THE E-BOX REMOTE FROM MAINS BEFORE CONNECTING/DISCONNECTING LED MODULES**

**This device falls under protection class I. Therefore, every E-box Remote has to be connected to a mains socket outlet with a protective earthing connection**

**Power connection**

	<b>L</b>	<b>N</b>	
Wire (CE)	Brown	Blue	Green/yellow
Wire (US)	Black	White	Green

**DMX connection**

<b>D+</b>	<b>D-</b>	<b>0V</b>
Data +	Data -	Data ground (shielding)

**Ethernet connection**

Pin	<b>1</b>	<b>2</b>	<b>3</b>	<b>4</b>	<b>5</b>	<b>6</b>	<b>7</b>	<b>8</b>
Function	TX+	TX-	RX+	NC	NC	RX-	NC	NC

**Eminere Remote connection**

CE version:

Mark	Function	Wire
Vcc	LEDs +	Red
D+	DATA +	Orange
D-	DATA -	White
0V	LEDS -	Black
⊕	Ground	Not connected

US version:

Mark	Function	Wire
Vcc	LEDs +	Red
D+	DATA +	Orange
D-	DATA -	White
0V	LEDS -	Black
⊕	Ground	Green

Example of connection

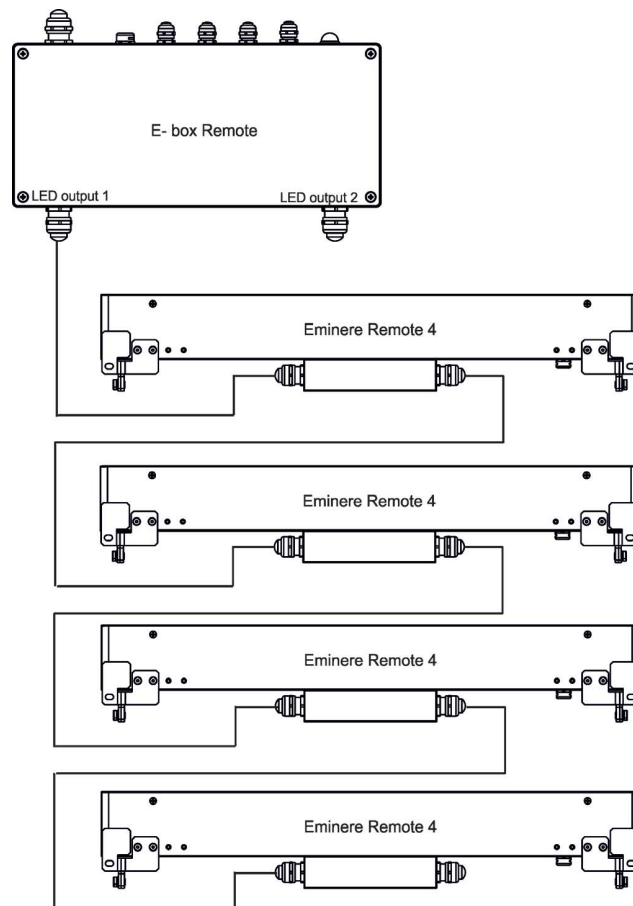

**NOTE:** Each line of Emineres Remote connected to the LED output of the E-box Remote has to be terminated at the last fixture.

**EITHER** connect a 120 Ohm resistor between terminals D+ and D- in the last fixture, **OR** terminate via RDM as described on page 14.



Ensure **ONLY** the last fixture in the line is terminated using **ONE** of the above methods!

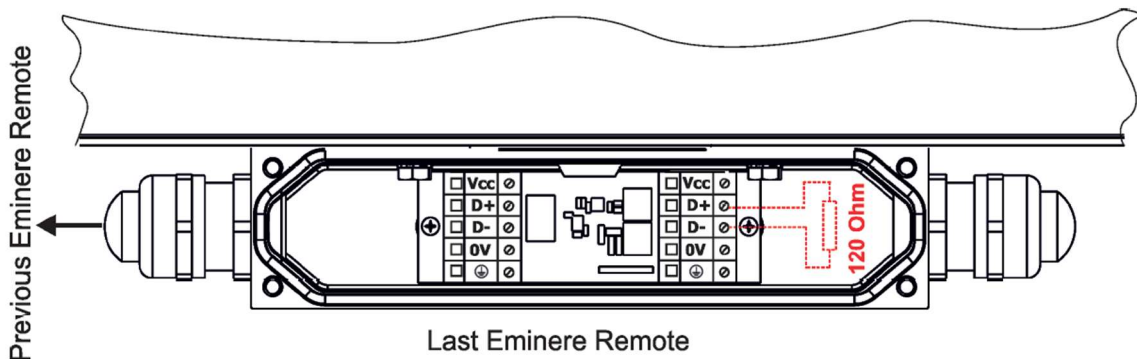

Number of connected Emineres to one LED output of the E-box Remote depends on the type of Eminere Remote and cable length.

The table states max. number of Eminere Remote modules connected to the E-box Remote.

Cable length *	Max. number of Emineres Remote connected to the E-box Remote			
	Eminere Remote 1	Eminere Remote 2	Eminere Remote 3	Eminere Remote 4
25 m	20	10	6	5
50 m	16	8	5	4
75 m	13	6	4	3
100 m	10	5	3	2

\* Cable length is the total cable length between E-box Remote and last connected Eminere Remote.  
Example: Total cable length = L1+L2+L3+L4

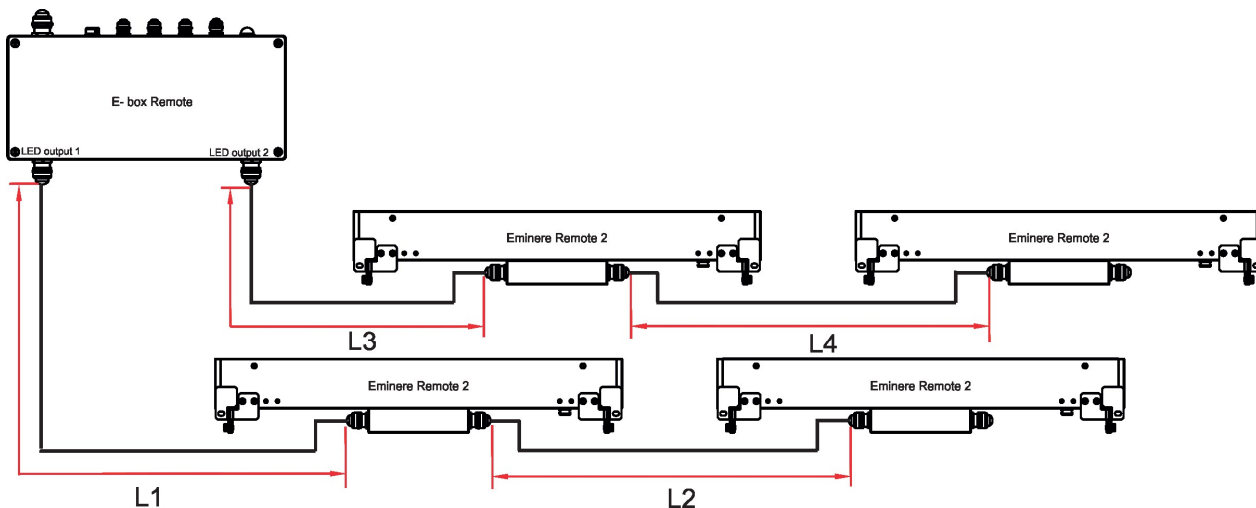

Max. number of Eminere Remote modules connected to the one output of the E-box Remote/E-box Remote Basic is stated in the following table:

Max. number of Emineres Remote connected to the one output of the E-box Remote			
Eminere Remote 1	Eminere Remote 2	Eminere Remote 3	Eminere Remote 4
16	8	5	4

Example: if you want to connect 20 Emineres Remote 1 to the E-box Remote, you may connect 16 Emineres Remote 1 to output 1 and 4 Emineres Remote 1 to output 2 (at total cable length of 25 m).

## 4. Eminere Remote modes

The E-box Remote menu allows you to switch connected Emineres Remote to the two modes:

**Standard** - LED modules are switched to an internal serial connection. DMX addressing of connected LED modules is made automatically (default DMX address = 1, changes can be done by the E-box Remote or by RDM). The Standard mode is set as default.

E-box Remote and connected LED modules will be shown in the RDM Manager.  
DMX address is shown on display, e.g "0001".

**Pass-Thr** - (Pass through). LED modules are switched to an internal parallel connection. DMX addressing of connected LED modules has to be done manually by means of the Robe Universal Interface (or its wireless version Robe Universal Interface WTX) and the software RDM Manager.

Only connected LED modules will be shown in the RDM Manager.  
Notice "Pass Thru" is shown on display.

Note: RDM manager and DMX controller cannot be connected to the E-box Remote at the same time.

Example of RDM manager connection:

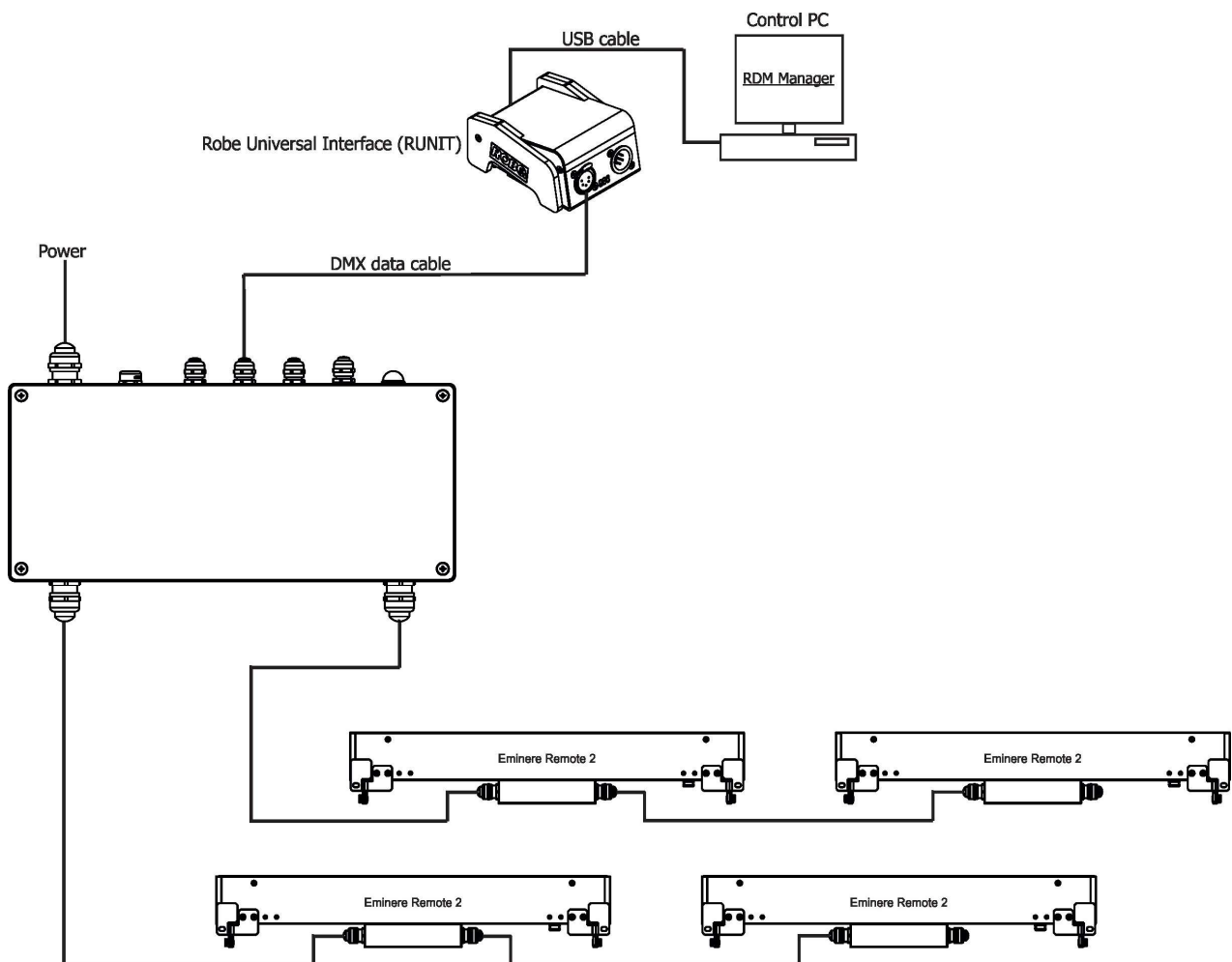

## Examples of RDM manager screenshots for Emineres.

Initial screen of the RDM manager – Standard mode:

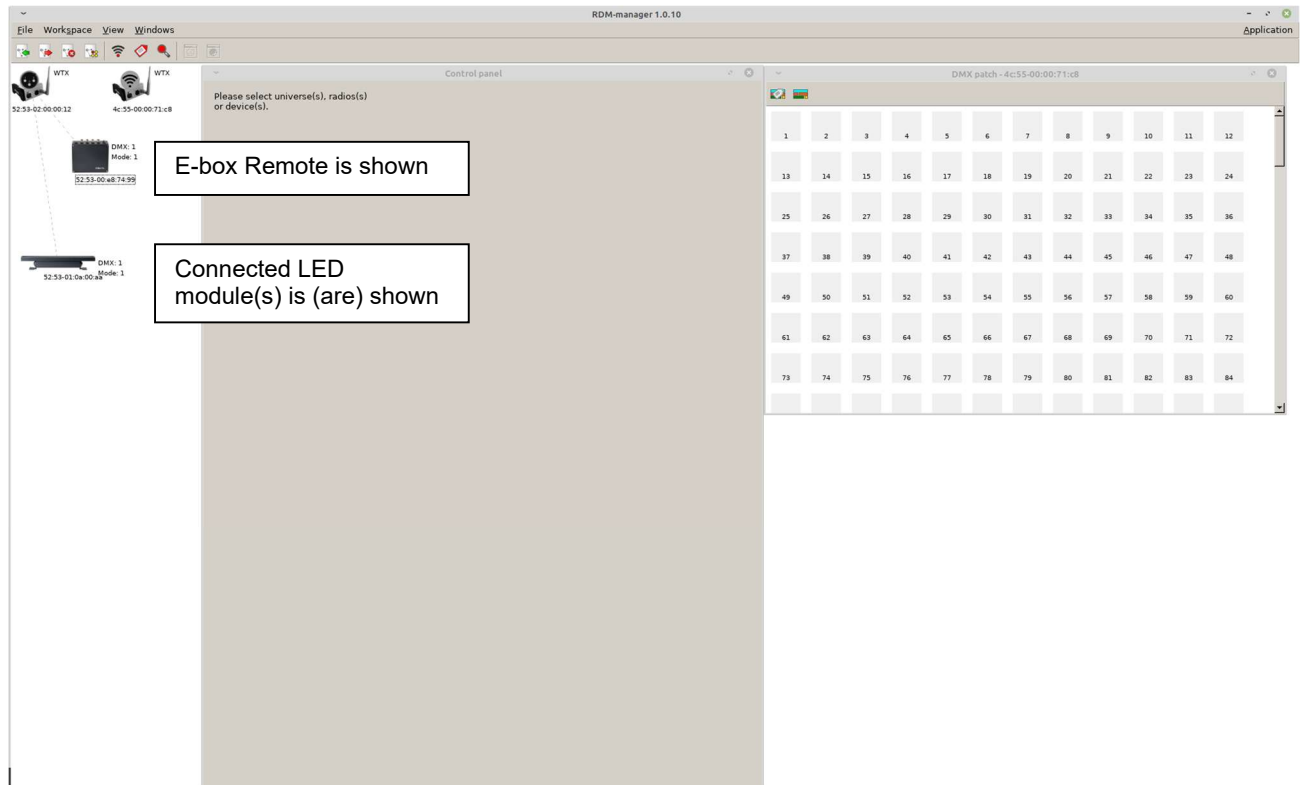

Initial screen of the RDM manager – Pass Through mode:

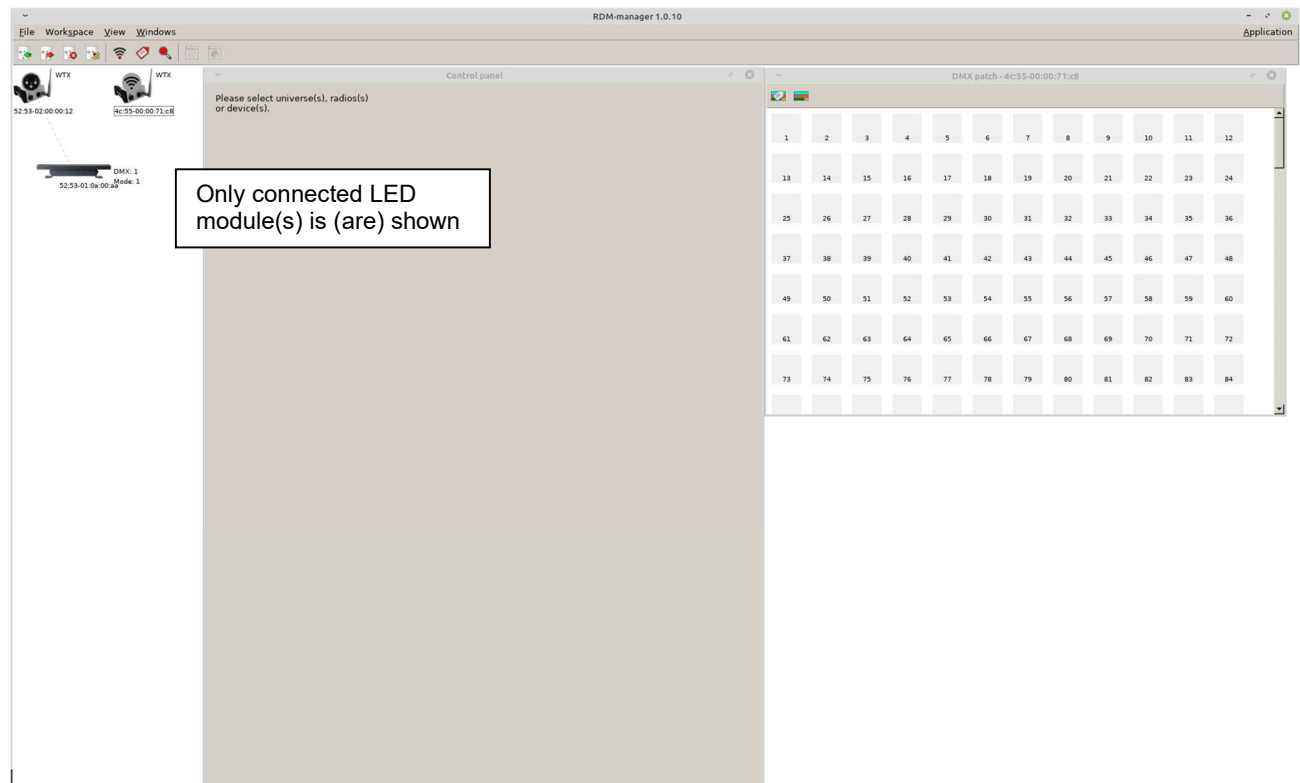

Click on the LED device to show and set options in the Control panel:

Occupied channels are displayed in the window DMX patch

Click on the green arrow to save adjusted values to the fixture

DMX preset and number of used channels

DMX address

Option Pixel swap is not available at Calumma modules

If some DMX Preset shows xx instead of number of channels, it means that DMX preset is reserved for future using (e.g. DMX Presets 8-10).

DMX Preset 01-4

DMX Preset 02-3

DMX Preset 03-12

DMX Preset 04-3

DMX Preset 05-6

DMX Preset 06-xx

DMX Preset 07-xx

DMX Preset 08-xx

DMX Preset 09-xx

DMX Preset 10-xx

DMX Preset 11-3

DMX Preset 12-4

DMX Preset 13-2

DMX Preset 14-xx

DMX Preset 15-xx

DMX Preset 16-xx

DMX Preset 17-4

DMX Preset 18-3

DMX Preset 19-2

DMX Preset 20-2

DMX Preset 21-xx

DMX Preset 22-xx

DMX Preset 23-xx

Options in the control panel:

The screenshot shows a 'Control panel' window with the following sections and options:

- Device:** 52:53-01:2e:00:7f (with a green play button icon)
- Product information:**
  - RDM protocol version: 0x0100
  - Device model ID: 0x010a
  - Product category: 0x0102
  - Software version: 18
  - Subdevice count: 0
  - Sensor count: 2
  - Manufacturer label: ROBE lighting s.r.o.
  - Device model description: Eminere
  - Device label:
- DMX512 setup:**
  - DMX512 footprint: 12
  - Current personality:  (dropdown)
  - Personalities count: 23
  - DMX address:  (spinner)
- Power/Lamp setup:**
  - Device hours: 0
- Configuration:**
  - Factory defaults:
- Control:**
  - Identify device:  (dropdown)
- Display settings:** (empty section)
- Manufacturer PIDs:**
  - Wireless Unlink 1-unlink:  (hex)
  - LED calibration 4byte HEX! (RGBW/RGBA):  (hex)
  - Insect friendly light (0 = off, 1 = on):  (hex)
  - Pixel swap (0-dis 1-act):  (hex)
  - Terminator active (0-dis 1-en):  (hex)

### Manufacturer PIDs

Wireless unlink - the item allows you to unlink the Eminere from a DMX transmitter (Wireless DMX version of the Eminere only).

LED calibration 4byte HEX! (RGBW/RGBA) - the item shows 4 bytes of calibration values for

calibrated white colours of RGBW(RGBA) Eminere.

E.g.



LED calibration 4byte HEX! (RGBW/RGBA):  (hex)

CTC channel has to be set to some calibrated white colour (21 DMX-1800K, 66 DMX-2700K, 91 DMX-3200K, 141 DMX-4200K, 211 DMX-5600K, 255 DMX-6500K) otherwise the item shows values

"ff ff ff ff" (and calibration values cannot be saved to the Eminere).

**Warning!**

**Changing and saving values in this item will effect calibrated white colour(s) of the Eminere .**

Insect friendly light - the item effects RGBA Eminere only. If the item is on, blue colour is not used in calibrated white colours. This modification of white lights results in a smaller attraction of white light for insects (mosquitos, moths..). The function is also available from DMX chart (channel Special Function, range 7-10 DMX).

Pixel Swap – the item allows you to swap the pixel order (for Eminere 2/3/4 only).

Terminator active - the item allows you to terminate line of Emineres at last Eminere.

Last Eminere on each DMX line may be terminated by setting the 'Manufacturer PID' 'Terminator active' to '1'.



But ensure that the fixture is not already terminated with a 120 Ohm resistor as described on page 9.



Terminator active (0-dis 1-en):  (hex)

The function "Pixel swap" from RDM control panel allows you to swap the pixel order.  
 Example:

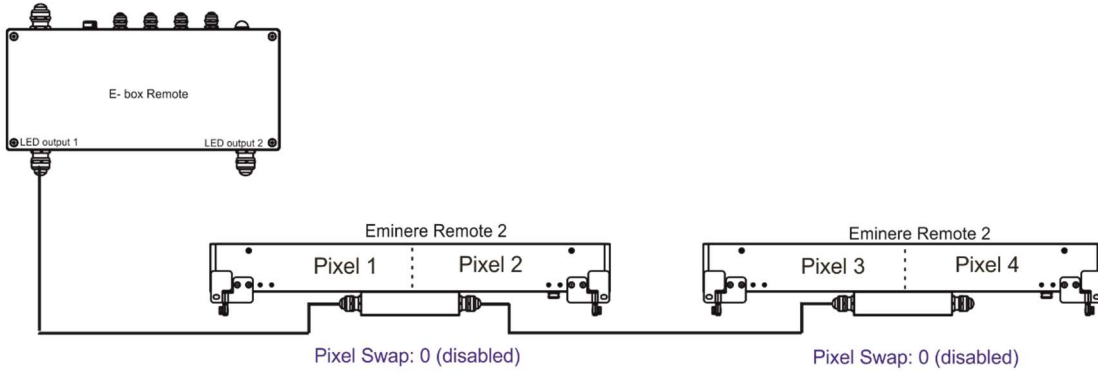

In case of reconnecting the E-box Remote on the other end of Emineres Remote line,  
 the pixel order is not in succession:

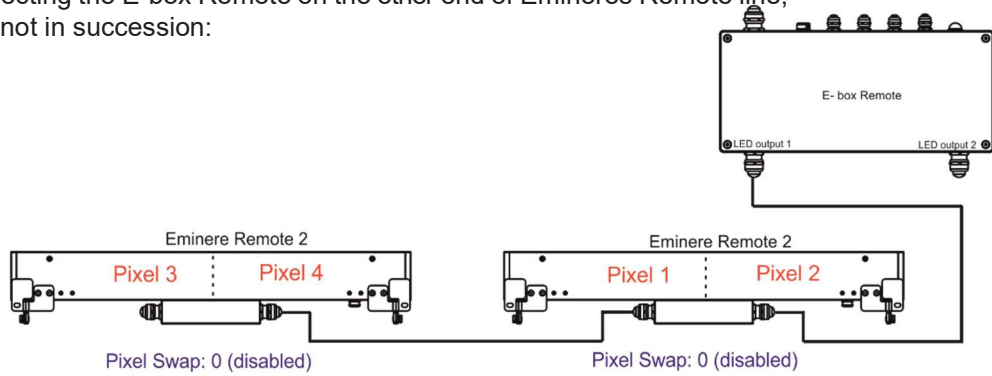

By means of the function "Pixel swap" you can rearrange pixels order.

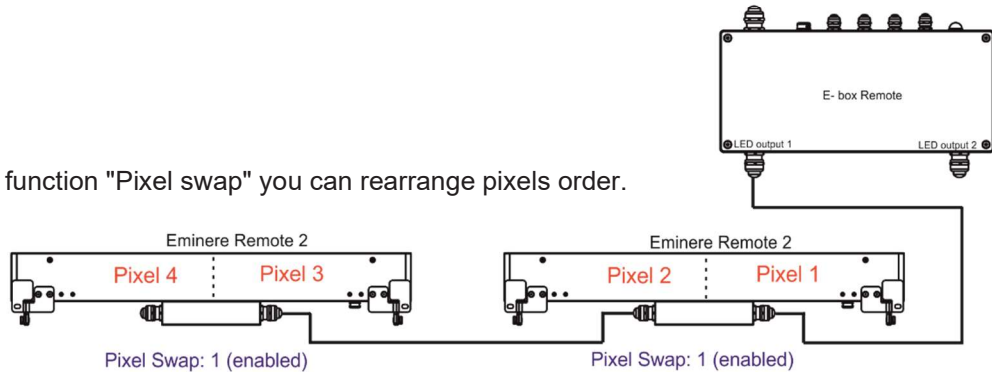



## 5. E-box Remote menu

The E-box Remote is equipped with 2-row LCD display and four buttons which allows to address the fixture and set the fixture's behaviour according to your needs.

The four control buttons have the following functions:

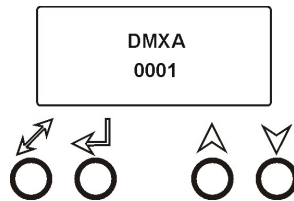
 - ESCAPE button - to escape function or menu.



 - ENTER button - to select a function or confirm adjusted value.

 - UP and DOWN buttons - to move within the menu.



**When you changed any setting of the E-box Remote, disconnect the E-box Remote from power and connect it to power again to activate changes in the E-box Remote setting.**



**Some menu items are not accessible if the option Pass-Thr is selected from the menu E-box mode (menu Personality).**

**These menu items are marked by # in the text below.**

### 5.1 DMX Addr

**# Set DMX Address** - use this menu item to set the DMX start address of the fixture, which is defined as the first channel from which the E-box Remote will respond to a DMX controller.

Note: if the option Pass-Thr is selected from the menu E-box mode, the sign "Pass-Thr" is displayed instead of the sign "DMX Addr", and the menu item Set DMX Address is not available.

**IP address** - select this menu item to set desired IP address. IP address is the Internet protocol address.

The IP uniquely identifies any node (fixture) on a network. There cannot be 2 fixtures with the same IP address on the network!

**Default Address.** This address is derived from fixture's MAC address and cannot be changed. Confirm the item "**Set Address**" to select this address.

**Custom Address.** IP address consists of four decimal numbers, each ranging from 0 to 255, separated by dots, e.g., 172.16.254.1. Each part represents a group of 8 bits (octet) of the address.

The following items "**IP Adr 1**", "**IP Adr 2**", "**IP Adr 3**", "**IP Adr 4**" allow you to set each part (number) of the address. After setting desired IP address, confirm the item "**Set Address**" to save this address.

**Network mask** - select this menu item to set desired network mask. A network mask is a 32-bit mask used to divide an IP address into subnets and specify the network's available hosts.

The following items "**Net.M.1**", "**Net.M.2**", "**Net.M.3**", "**Net.M.4**" serve for setting of each part (number) of the net mask.

After setting desired network mask, confirm the item "**Set Net M.**" to save adjusted values.

### 5.2 Info

Use this menu to read useful information about the fixture.

**Software version** - select this menu item to read software versions of the E-box Remote and connected Emineres Remote.

**Databox** - version of the E-box Remote

**WL** - version of wireless DMX module (if installed).

**IP Addr** - this menu item shows the current IP address (the IP address "runs" on display).

**RDM UID** - select this menu item to read the RDM UID (the RDM UID "runs" on display).

**MAC Adr** - select this menu item to read the MAC address (the MAC address "runs" on display).

**# Outputs Info** - information about Emineres Remote connected to the LED outputs.

Example:

**Output 1 Info** .....information about E-box Remote output 1

**Fixtures Cnt: 12**.....Number of connected Emineres to the selected output.

If some LED output is not used, the message "No output" will be displayed.

**Temp** - temperature inside the E-box Remote.

## 5.3 Personality

Use this menu to modify the E-box Remote operating behaviour.

**# Devices** - use this menu to find and set connected LED modules.

**Search** – The menu item finds connected Emineres Remote. After finishing searching procedure, number of found LED modules will be displayed and if you want to founded LED modules save, select the option Y (option N leaving the menu without saving) and press the ENTER button.

**Sort** – The option allows you to sort LED modules according selected DMX preset for colour variant.

Option **Default** means that LED modules will be sorted according last DMX preset (LED module remembers its last DMX mode, in case of change of the E-box you do not need to set DMX mode for each LED module, sorting will be done according last DMX mode).

Note: Default DMX mode for new LED modules (default from factory) is first DMX mode for corresponding colour variant of the LED module (Mode 1-for RGBW/RGBA variant, Mode 11-for TW and PW variant).

**Settings** – The menu item allows you to select desired LED output and display LED modules connected to the LED outputs. The LED modules are identified by RDM UID. At every LED module you can change DMX address and DMX preset.

Note: If you change DMX address or DMX preset, you will need to run the procedure **Sort** again and new footprint will be saved.

**Locate** – The menu item allows you to identify LED modules, selected LED module will light.

**DMX Input** - this menu allows you to choose desired DMX data input:

**Wired DMX** - DMX signal is received by means of the standard DMX cable.

**Wireless\*** - DMX signal is received by means of the inbuilt wireless DMX module.

**Wireless Out DMX\***- the fixture receives wireless DMX and sends the signal to its wired DMX output. The fixture behaves as a " Wireless/Wired" adaptor.

**Ethernet** - DMX signal is received by means of the Ethernet cable.

\* If wireless DMX module is installed.

**Ethernet Settings** - use the menu item to select and set desired operating mode.

**Ethernet mode** - use the menu to select a protocol.

**Artnet** - fixture receives Artnet protocol

**sACN** - fixture receives sACN protocol

**gMAI** - fixture receives MANet I protocol

**gMAII** - fixture receives MANet 2 protocol

**ArtNet Settings** - use the menu item to set parameters for ArtNet operation.

**ArtNet Uni.** - selection of the ArtNet Universe (1-12)

**Net** - selection of a network (0-127)

**Sub-Net** - selection of a subnet (0-15).

**Universe** - selection of a Universe (0-15).

Menu items "ArtNet Uni. " and "Universe" allow a "crossing of Universes".

**sACN Settings** - use the menu item to set parameters for sACN operation.

**sACN Uni.** - selection of the sACN Universe (1-1...12-12). A universe from a range of 1-63999 can be assigned to the selected universe. It allows a "crossing of Universes".

**MANet Settings** - Use this menu to set parameters for MANet operation.

**MA Uni** - MANet I (II) universe. The value of this item can be set in range of 1-256.

**MA S. ID** - MANet I(II) session ID. The value of this item can be set in range of 1-32.

**IGMP rep** - repeating time for Internet Group Management Protocol (Off, 1s-10s).

**Display Settings** - this menu allows you to change the display settings.

**Display Off Timer** - if this item is on, the display will be switched off 2 minutes after last pressing any button on the control panel.

**Display Lightness** - select this menu item to adjust the display intensity (0-100%).

**Display Contrast** - select this menu item to adjust contrast of the display (0-100%).

**# DMX Hold** - if the function is on, the fixture keeps last received DMX values in case that DMX data receiving was interrupted (e.g., disconnected DMX cable or DMX controller).

**E-box mode** - this menu item allows you to select a way of Emineres Remote connection.

**Standard** - Emineres Remote are switched to the internal serial connection.

**Pass-Thr** - Emineres Remote are switched to the internal parallel connection.



**Important: Switch Off/On the E-box Remote after changing the E-box mode.**

**Output Data** - this menu item allows you to block sending data to the LED outputs of E-box Remote.

**Enabled** - The E-box Remote sends data to the connected LED modules.

**Disabled** - Sending data to the connected LED modules is blocked. This option has to be selected if you wish to use Initial DMX values saved in the LED modules.

#### Setting and running initial DMX values in connected LED module

1. Switch the connected LED module to DMX mode 7 (by RDM Manager or by REAP).
2. Set desired effects (by DMX console)
3. Save effects to the LED module by using command "Save current DMX values to fixture as initial DMX values" (DMX range 1-2, channel 1).
4. Set the item "Output Data" to **disabled** (by the E-box Remote menu or by REAP).

Note: after disabling output data by the REAP screen, click on the red button "Reset Now):



5. Switch the E-box Remote and on. Connected LED module (modules) should light with initial DMX values.

**Default setting** - select this option to set fixture personalities to the default (factory) values.

## 5.4 Special settings

**Wireless\*** - wireless DMX information. The menu allows to read some information about wireless DMX operation

**Stat** - wireless status. Use the menu to read wireless DMX status.

**Unlink** - use this item to unlink the fixture from wireless DMX.

\* If wireless DMX module is installed

**Software Update** - the menu item switches the E-box Remote to the update mode.

If the software update is done by means of the software ROBE RDM Uploader, switching the E-box Remote to the update mode will be done automatically.

## 6. Robe Ethernet Access Portal (REAP)

### 6.1 Settings on computer

Your computer needs to be connected to the fixtures through the means of Ethernet wired network and a network switch. The computer needs to have configured network settings in order to be able to communicate with the fixtures through the network.

To do this, refer to the manual of your computer how TCP/IP network settings should be done. Set up manual IP address of your computer. The Ethernet network connection (Local LAN) typically needs to be set to 2.x.x.x address, for example 2.0.0.10, assuming that no other computer on the network contains such an address while keeping all ROBE fixtures in default IP settings. Netmask of the computer should be 255.0.0.0

### 6.2 Settings on fixtures

Typically, make sure to use the default 2.x.x.x IP address as provided. There is no need to set the fixture into Art-Net mode.

### 6.3. REAP menu screens

Type the IP address of the ROBE fixture to your web browser, e.g. <http://2.247.92.33>, enter the user name: **robe** and the password: **2479**, the first menu screen of the ROBE fixture will appear.

### 6.4 Status screen

The screen gives you a fast overview of fixture settings.

The screenshot shows the ROBE REAP status screen. At the top, there is a navigation bar with 'Status', 'Personality', 'Devices', and 'Settings'. The main content area is titled 'Device status' and contains several panels:

- DMX/RDM settings** (gear icon):
  - DMX address: 1
  - DMX preset: pixel
  - DMX input: ethernet
  - IP address: 10.244.116.153
  - Network mask: 255.0.0.0
  - MAC address: 00:0d:19:03:74:99
  - RDM UID: 52:53:00:a8:74:99
  - RDM label: Eminere Ebox
- Outputs state**:
  - Receiving data: no
  - Total footprint: 0
- Device temperatures**:
  - Driver board: 36°C current
- Wireless state** (gear icon):
  - State: not installed
  - Signal strength: ...
- Software versions**:
  - Databox: 4.5
- Status messages**: (empty)

The background colour of the top row of the screen with the name and RDM label of the fixture denotes state of the fixture:

- Black colour - fixture is ready for operation
- Yellow colour - fixture does not communicate with computer
- Red colour - fixture with error messages

The icon  allows you to change some values in a corresponding table.

## 6.5 Personality screen

The screen allows you to change some fixture settings by clicking on the icon  in a corresponding table .

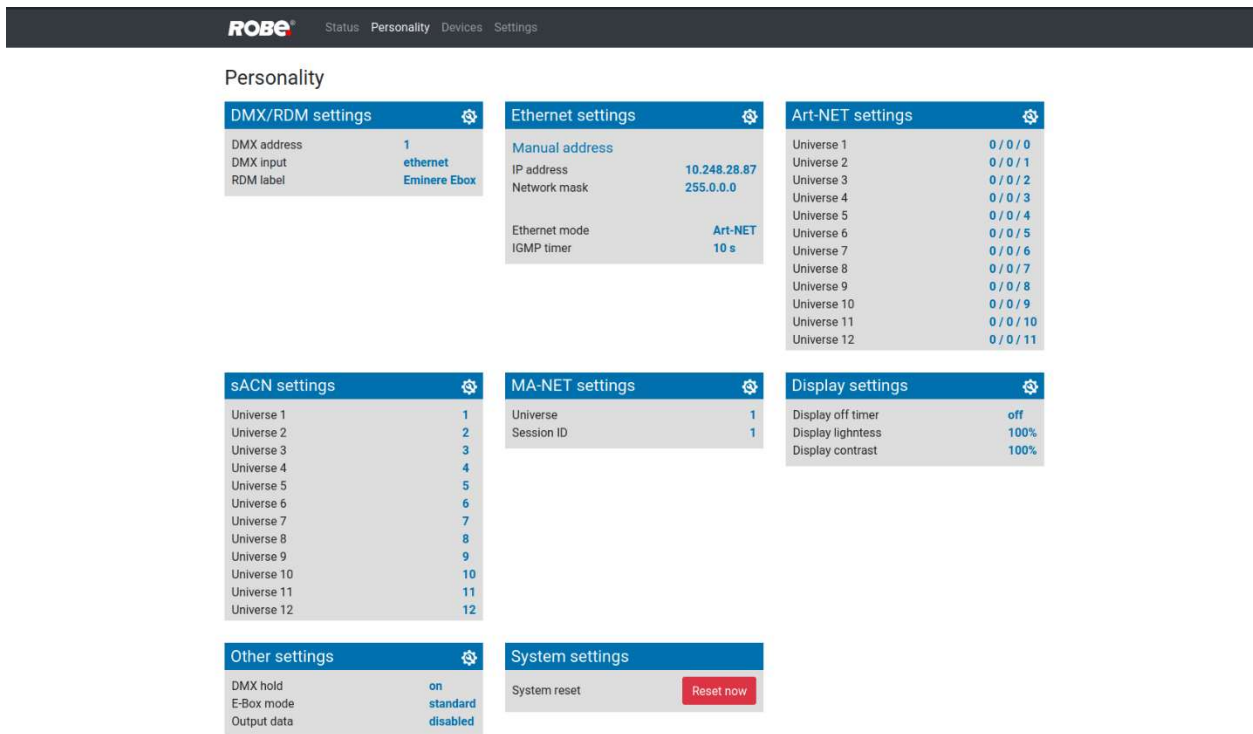

**Personality**

**DMX/RDM settings**

DMX address	1
DMX input	ethernet
RDM label	Eminere Ebox

**Ethernet settings**

Manual address	
IP address	10.248.28.87
Network mask	255.0.0.0
Ethernet mode	Art-NET
IGMP timer	10 s

**Art-NET settings**

Universe 1	0 / 0 / 0
Universe 2	0 / 0 / 1
Universe 3	0 / 0 / 2
Universe 4	0 / 0 / 3
Universe 5	0 / 0 / 4
Universe 6	0 / 0 / 5
Universe 7	0 / 0 / 6
Universe 8	0 / 0 / 7
Universe 9	0 / 0 / 8
Universe 10	0 / 0 / 9
Universe 11	0 / 0 / 10
Universe 12	0 / 0 / 11

**sACN settings**

Universe 1	1
Universe 2	2
Universe 3	3
Universe 4	4
Universe 5	5
Universe 6	6
Universe 7	7
Universe 8	8
Universe 9	9
Universe 10	10
Universe 11	11
Universe 12	12

**MA-NET settings**

Universe	1
Session ID	1

**Display settings**

Display off timer	off
Display lightness	100%
Display contrast	100%

**Other settings**

DMX hold	on
E-Box mode	standard
Output data	disabled

**System settings**

System reset Reset now

Important: if you set the item “Output data” to disabled, click on the red button “Reset now” to reset the E-box

## 6.6 Devices screen

The screen allows you to show connected LED modules to the E-box fixture.

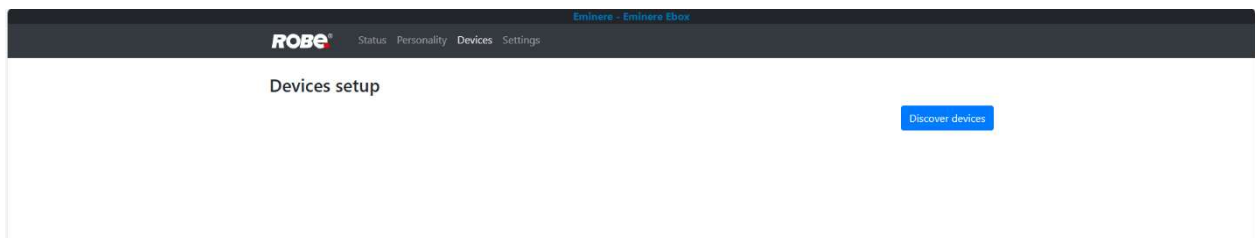

**Devices setup**

Discover devices

Click on the button “Discover devices” and LED modules connected to the E-box fixture will appear.  
Example:

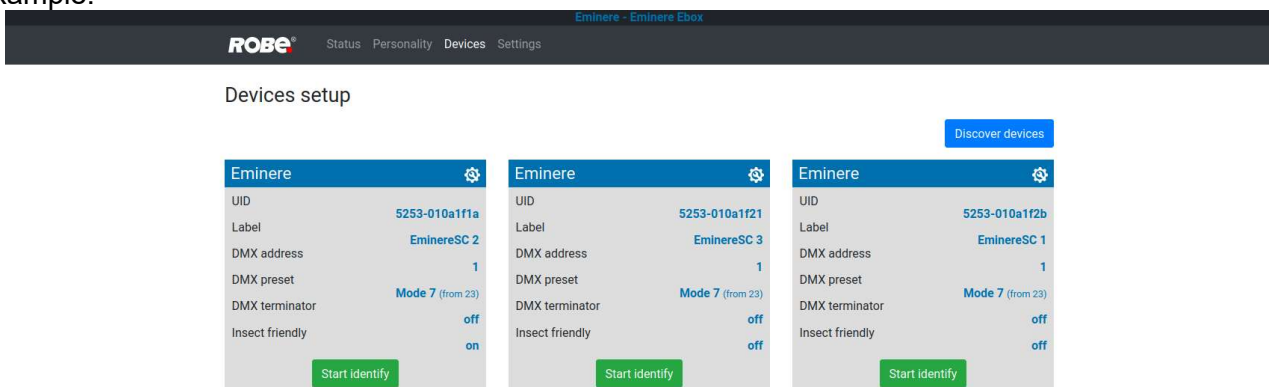

**Devices setup**

Discover devices

Eminere	
UID	5253-010a1f1a
Label	EminereSC 2
DMX address	1
DMX preset	Mode 7 (from 23)
DMX terminator	off
Insect friendly	on
<span style="background-color: #28a745; color: white; padding: 2px 5px; border-radius: 3px;">Start identify</span>	

Eminere	
UID	5253-010a1f21
Label	EminereSC 3
DMX address	1
DMX preset	Mode 7 (from 23)
DMX terminator	off
Insect friendly	off
<span style="background-color: #28a745; color: white; padding: 2px 5px; border-radius: 3px;">Start identify</span>	

Eminere	
UID	5253-010a1f2b
Label	EminereSC 1
DMX address	1
DMX preset	Mode 7 (from 23)
DMX terminator	off
Insect friendly	off
<span style="background-color: #28a745; color: white; padding: 2px 5px; border-radius: 3px;">Start identify</span>	

Click on the icon  to change some values in a corresponding table.

If you click on the green button “Start identify”, the corresponding LED module will start flashing.

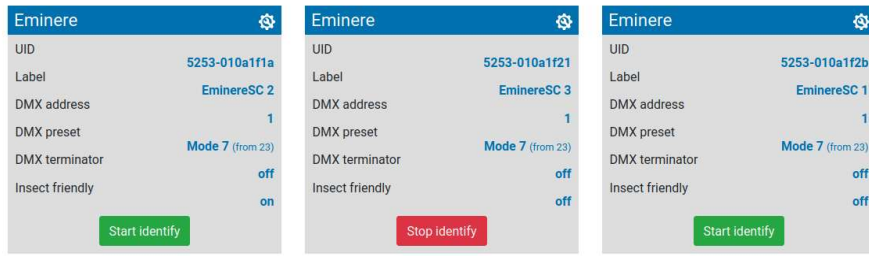

## 6.7 Settings screen

The screen allows you to change password to REAP.

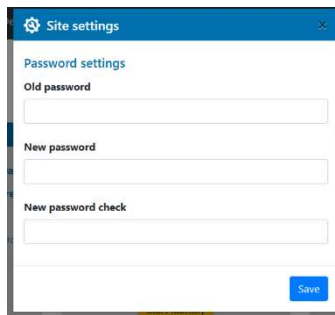

## 7. Software update

Software update of the E-box Remote and connected LED modules can be done via an Ethernet connection between a computer running a ROBE Uploader software and E-box Remote or using the Robe Universal Interface (Robe Universal Interface WTX), DMX connection and the ROBE RDM Uploader software. The ROBE Uploader is a software for automatized software update of ROBE fixtures. The ROBE Uploader switches E-box Remote and connected LED modules to the update mode automatically. Please see <https://www.robe.cz/robe-uploader/> for more information about the ROBE Uploader.



**After updating the E-box Remote from older version to version 4.0, the E-box Remote and connected Eminere Remote modules will be set to default (factory) values including DMX presets and addresses!**

**Setting of Calumma XS modules will not be changed.**

**Update from the version 4.0 to newer version will not affect setting of the E-box Remote and connected Eminere Remote and Calumma XS modules.**

**Version of the Robe uploader has to be 4.16 and higher!**

1. Option “Standard” is selected from the menu “E-box mode” and LED modules are connected in series, the E-box Remote will be updated including connected LED modules. Only E-box Remote will be shown in the ROBE Uploader. You have to use the file EminereEbox.lib in the ROBE Uploader for this operating mode.



**Note:** File EminereEbox.lib includes software for E-box Daisy/Star/Lite, E-box Remote, Emineres, Emineres UV, Emineres Remote, Emineres Remote UV and Calummas XS.

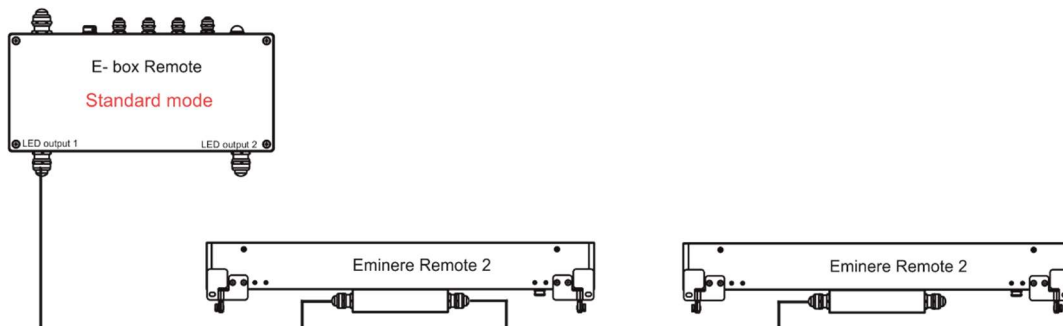

2. Option “Pass-Thr” is selected from the menu “E-box mode” and LED modules are connected in series. Set the E-box Remote to the Standard mode and switch it off/on. Only E-box Remote will be shown in the ROBE Uploader. You have to use the file EminereEbox.lib in the ROBE Uploader for software update of the E-box and connected LED modules.

After updating, set the E-box Remote to the Pass-Thorough mode and switch it off/on.

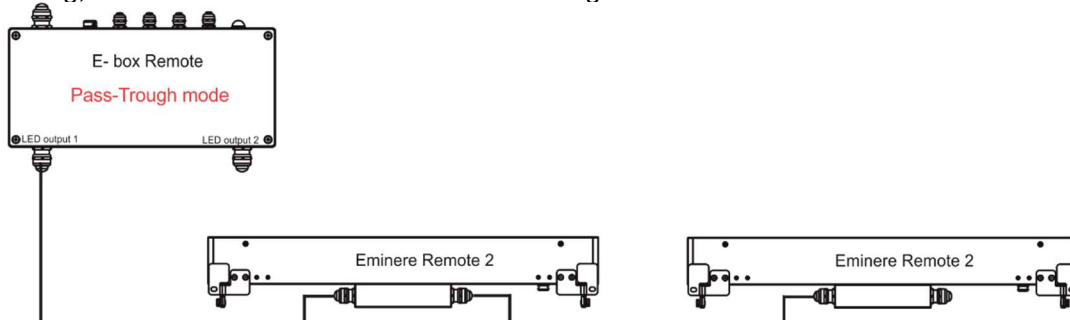

3. Option “Pass-Thr” is selected from the menu “E-box mode” and LED modules are connected in parallel (it is a typical operating mode for Calummas XS).

In the first step you have to update connected LED modules by means of the file Calumma.lib in the ROBE Uploader. In case of combination of Calummas XS and Emineres Remote, after updating of Calummas XS, update Emineres Remote using the file Eminere.lib. Only LED modules will be shown in

the ROBE Uploader. The E-box will not be updated, only connected LED modules.

In the second step you have to set the E-box Remote to the Standard mode and switch it off/on.

Use the file EminereEbox.lib in the ROBE Uploader for software update of the E-box.

Only E-box Remote will be shown in the ROBE Uploader.

After updating the E-box Remote, set the E-box Remote to the Pass-Thorough mode and switch it off/on.

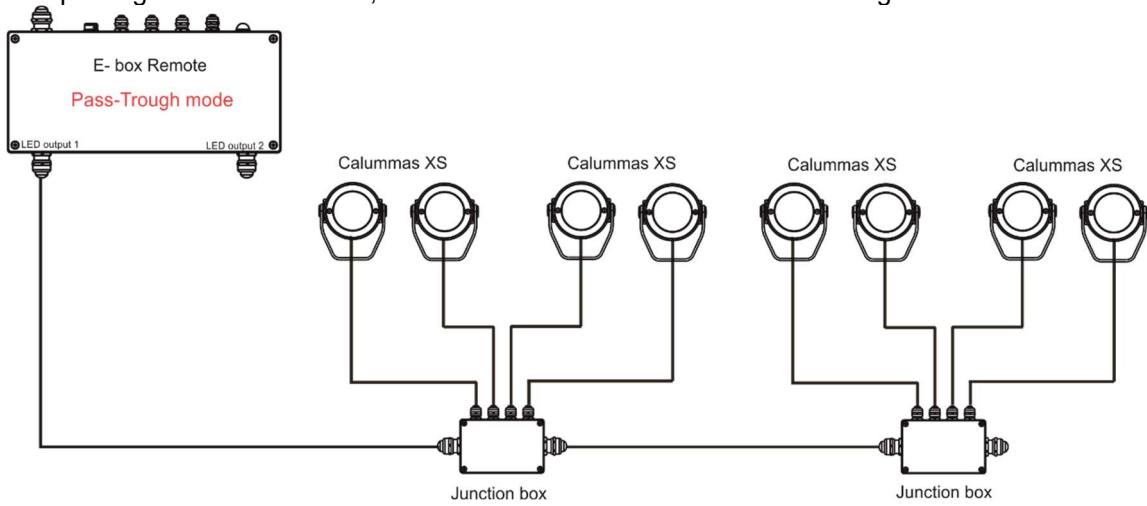

Examples of connections for software update:

By means of the Ethernet connection

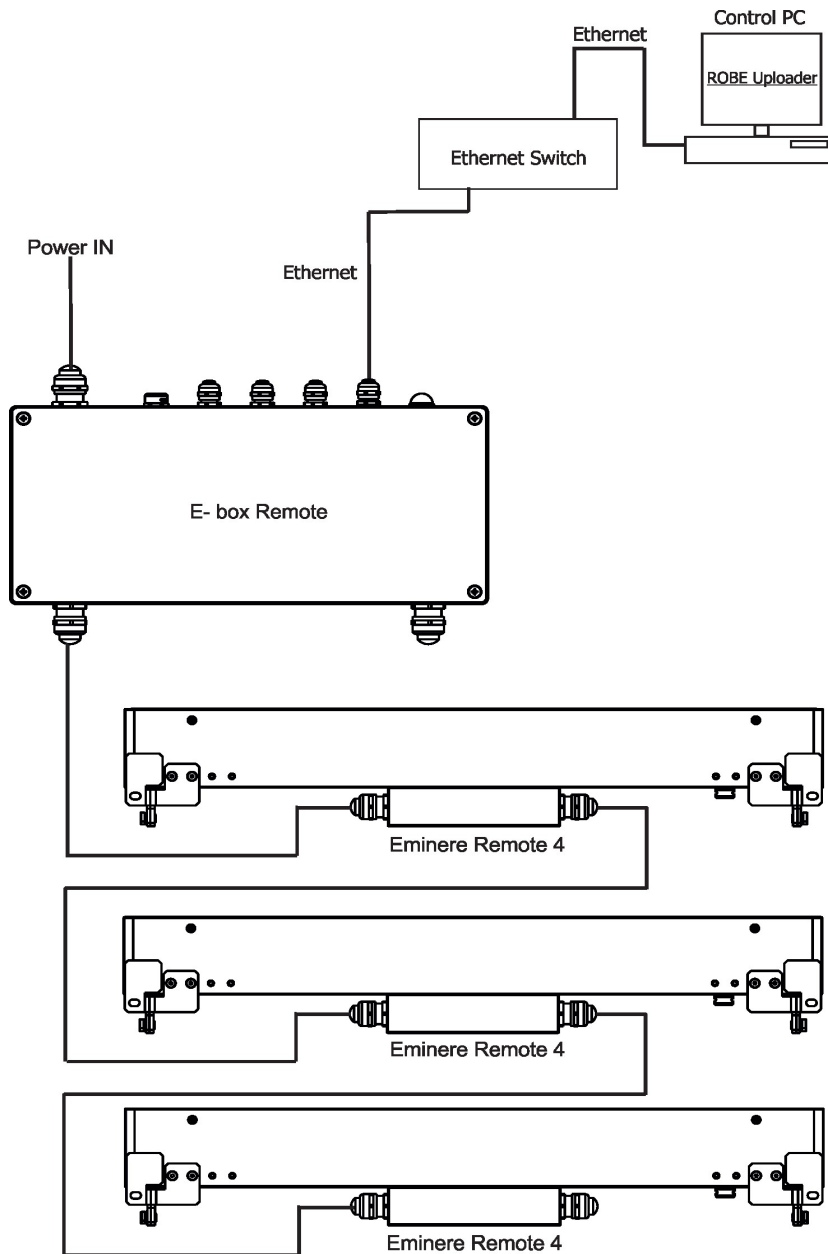

By means of DMX connection and the Robe Universal Interface (Robe Universal Interface WTX)

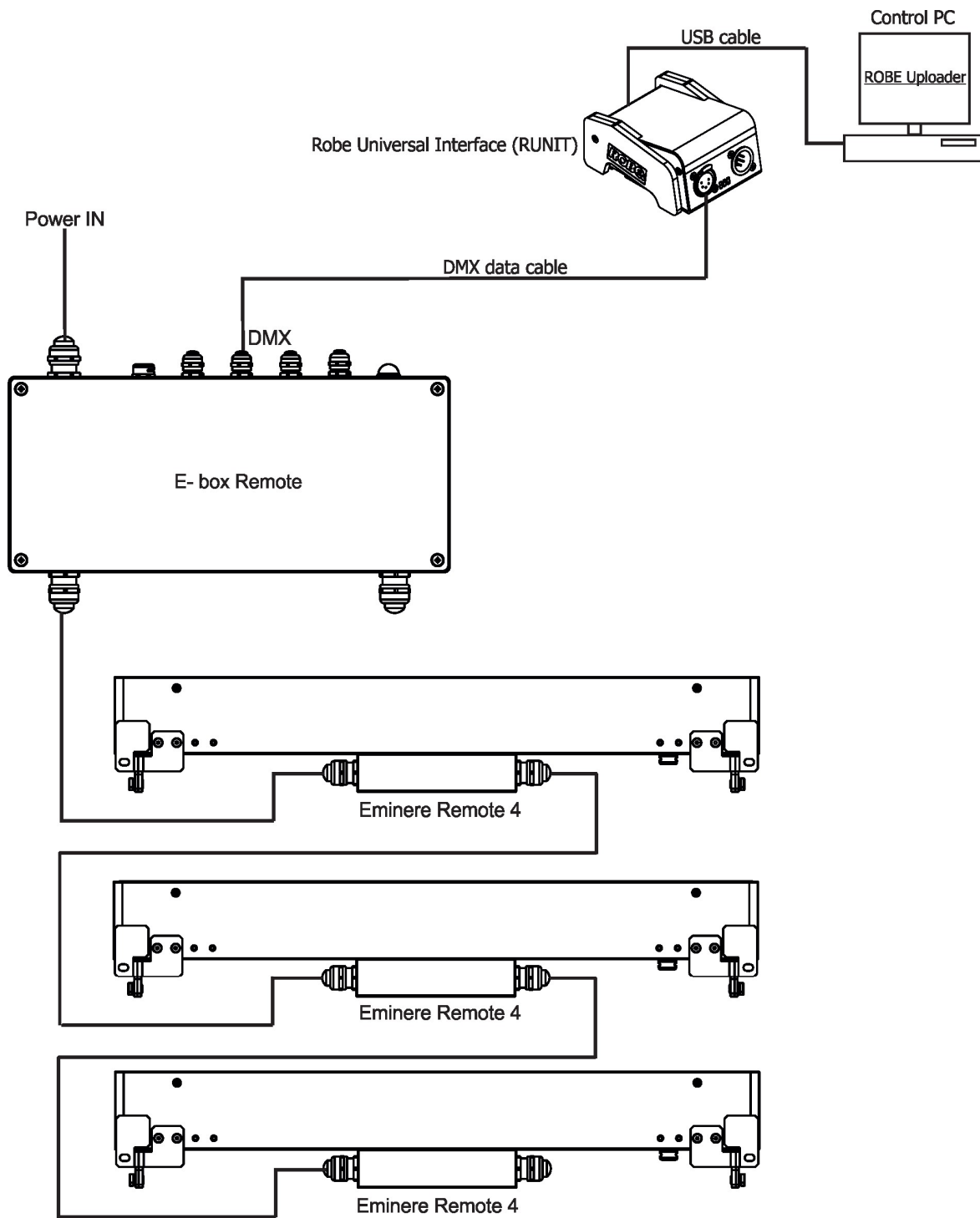

By means of DMX connection and the Robe Universal Interface (Robe Universal Interface WTX) -Calumma XS

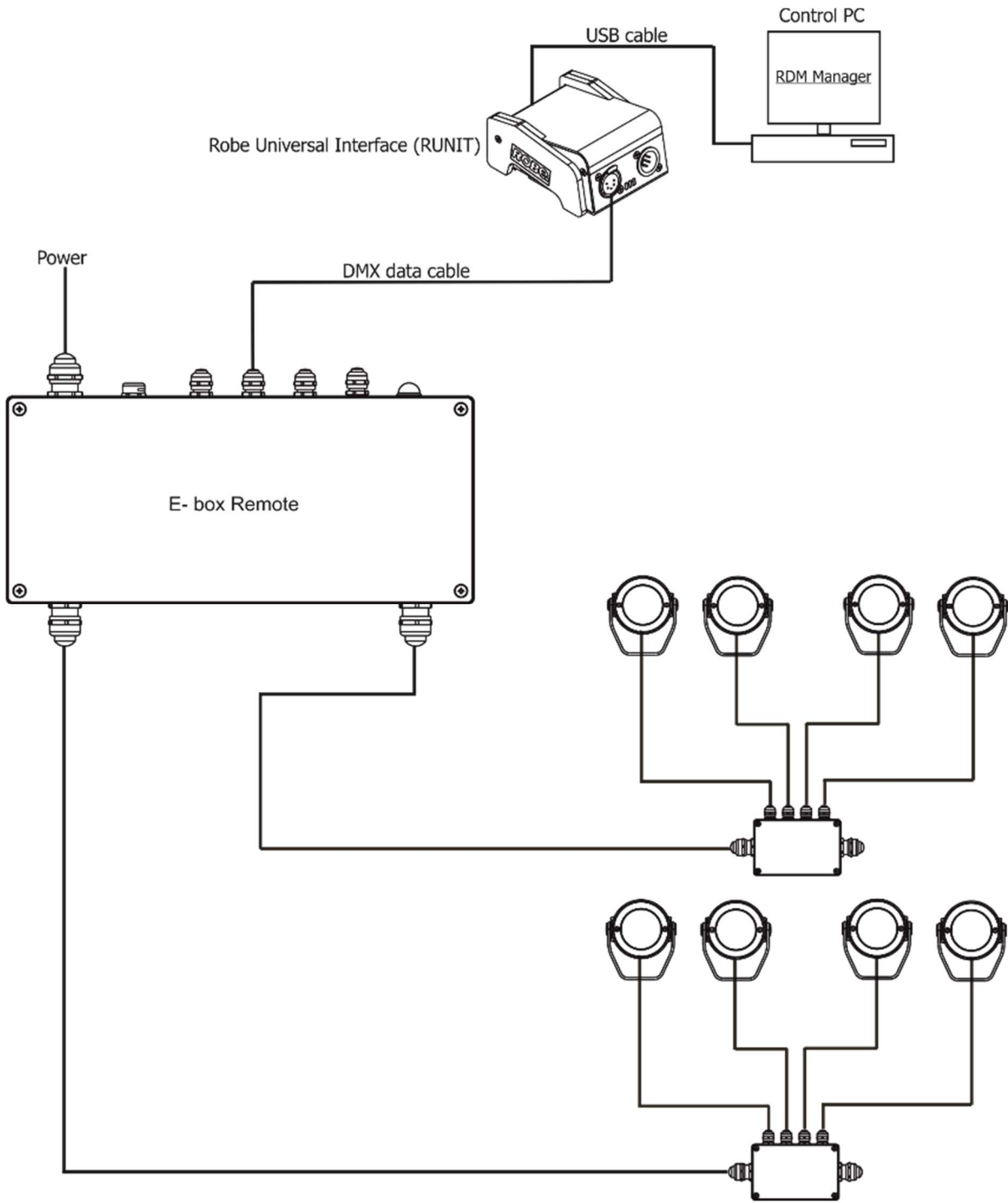

## 8. Technical specifications

Input voltage	120-240 V AC; 277V AC
Frequency	50/60Hz
Power consumption	520W
Fuse 1	T6.3A/500V AC
Fuse 2	T8A/250V AC
Fuse 3	T8A/250V AC
Inrush current	COLD START 35A(twidth=1800µs measured at 50% Ipeak) at 230VAC
LED Output	
Number of outputs	2
Voltage	48V DC
Max output power	380W per output
Total Output power	480W max. per fixtures
Control	2-row LCD display & 4 buttons
Supported protocols	USITT DMX 512, RDM, ArtNet, MA Net, MA Net2, sACN, Kling-Net
Connection	
Power IN	terminal block
Ethernet IN/OUT	terminal block
DMX IN/OUT	terminal block
LED Outputs	terminal block
Operating ambient temperature range	-20/+40°C (-4°F / +104°F)
Cooling System	convection
Protection factor	IP65 (CE), Suitable for Wet Locations (US)
IK Rating	IK10
Weight	5.5 kg (12.13 lbs)

Dimensions  
mm [inch]

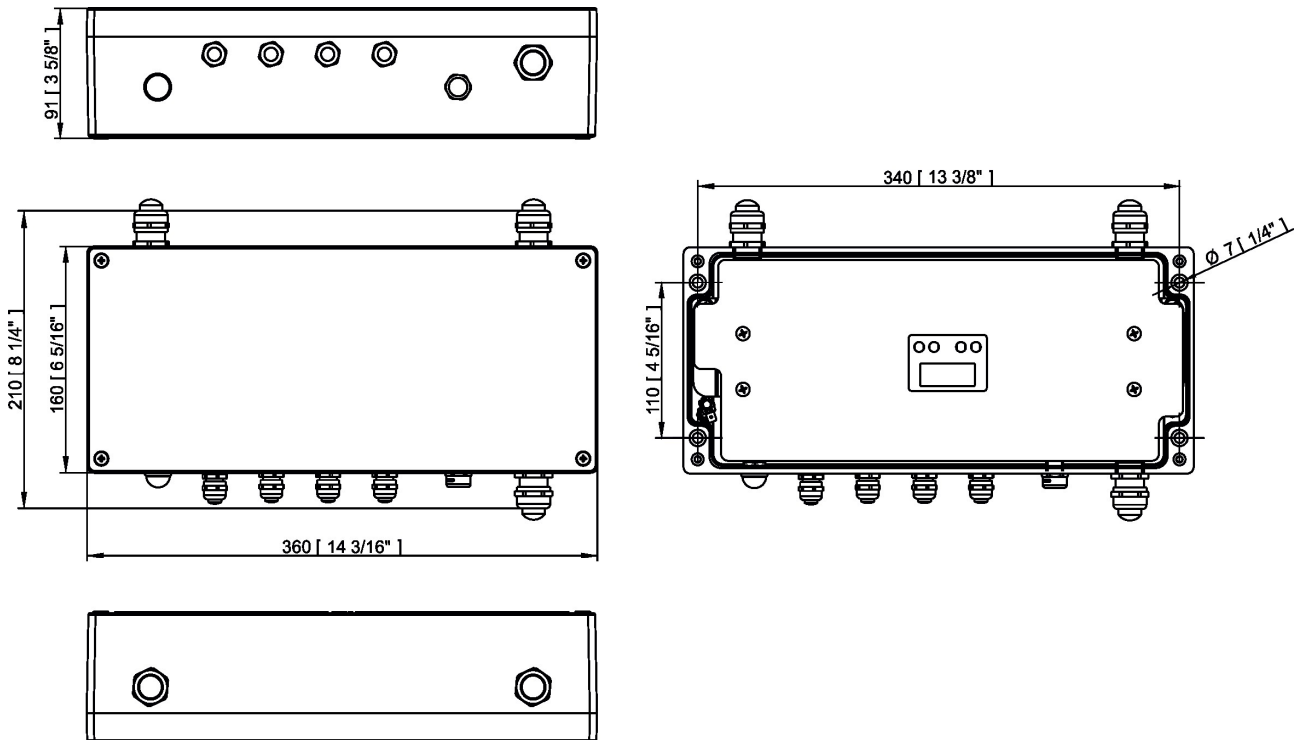

### Included items

- 1 x E-box Remote
- 2 x Reducing seal (P/N 13051388)
- 1 x User manual

## 9. Disposing of the product

To preserve the environment please dispose or recycle this product at the end of its life according to the local regulations and codes.

## 10. Change Log

This section summarizes changes in the user manual.

Version of the manual	Date of issue	Description of changes
1.1	26/01/2022	Description of connection blocks modified
1.2	24/02/2022	Description of the fixture corrected
1.3	14/03/2022	Design of the manual changed
1.4	07/04/2022	Menu DMX preset added, menu Devices removed, Eminere connection changed
1.5	28/04/2022	Eminere connection changed
1.6	17/08/2022	Eminere connection changed
1.7	08/12/2022	DMX chart ver. 3.1 added
1.8	05/01/2023	Description of fixture update changed
1.9	08/02/2023	DMX chart ver. 3.2 (Eminere), DMX chart ver. 1.2 (Calumma), REAP added
2.0	22/02/2023	Cable gland installation changed
2.1	23/06/2023	RB4176 description added
2.2	05/03/2024	Menu item Test program removed
2.3	07/02/2025	Rubber seal P/N 13051388 added
2.4	31/03/2025	Inrush current added to Technical specifications
2.5	19/06/2025	Screens of REAP changed

June 19, 2025

Specifications are subject to change without notice.

Copyright © 2021-2025 Robe Lighting - All rights reserved

Made in CZECH REPUBLIC by ROBE LIGHTING s.r.o. Palackeho 416/20 CZ 75701 Valasske Mezirici

**DMX protocol for: Eminere 1/2/3/4; Eminere Side 1/2/3/4;  
Eminere Inground 2/4; Eminere Remote 1/2/3/4;  
UVinere 2/4; UVinere Remote 1/2/4**

Version: 3.3 (23 modes in total), software version 3.0 and higher

Mode/Channels in all								Mode 1: RGBW(A)-8bit, Mode 2: RGB 8-bit, Mode 3: full RGBW(A)	
1	2	3	4	5	6	7	8-10	Mode 4: White-full control, Mode 5: Reduced RGBW(A)	
4	3	12	3	6	8	15	Reserved	Mode 6- Reduced RGBW(A)+white control	
								Mode 7- full RGBW(A)+virtual colour wheel	
								RGBW(A) / RGB modes	
Mode/channels							DMX Value	Function	Type of control
1	2	3	4	5	6	7			
-	-	-	-	-	-	1	0	<b>Special functions</b> No function	step
								<i>To activate following functions , stop in DMX value for at least 3 sec.</i>	
							1-2	Save current DMX values to fixture as initial DMX values.	step
							3-4	Show saved initial DMX values	step
							5-6	Run factory demo sequences at switching fixture on (without DMX)	step
							7-8	Insect friendly light On (RGBA version only)	step
							9-10	Insect friendly light Off (RGBA version only)	step
							11-255	Reserved	
1	1	1	-	1	1	2	0-255	<b>Red</b> Red LEDs saturation control (0-100%)	proportional
-	-	2	-	-	-	3	0-255	<b>Red Fine</b> Red LEDs saturation control fine	proportional
2	2	3	-	2	2	4	0-255	<b>Green</b> Green LEDs saturation control (0-100%)	proportional
-	-	4	-	-	-	5	0-255	<b>Green Fine</b> Green LEDs saturation control fine	proportional
3	3	5	-	3	3	6	0-255	<b>Blue</b> Blue LEDs saturation control (0-100%)	proportional
-	-	6	-	-	-	7	0-255	<b>Blue Fine</b> Blue LEDs saturation control fine	proportional
4	-	7	-	4	4	8	0-255	<b>White (Amber)</b> White LEDs saturation control (0-100%)	proportional
-	-	8	-	-	-	9	0-255	<b>White (Amber) Fine</b> White LEDs saturation control fine	proportional
-	-	9	1	-	5	10	0	<b>Green correction</b> Uncorrected white	step
							1-127	Minus green --> uncorrected white	proportional
							128	Uncorrected white (128=default)	step
							129-255	Uncorrected white --> Plus green	proportional
-	-	10	2	-	6	11	0	<b>Colour temperature correction (CTC)</b> No function	step
							1-10	Tungsten dimming 2700 K	step
							11-20	Tungsten dimming 3200 K	step
							21-255	Colour temperature changing from 1800 K --> 6500 K	proportional

DMX protocol

Mode/channels							DMX Value	Function	Type of control
1	2	3	4	5	6	7			
								(21-1800K, 66-2700K, 91-3200K,141-4200K, 211-5600K, 255-6500K)	
-	-	-	-	-	-	12		<b>Virtual Colour Wheel</b>	
							0	No function	step
							1-2	White 1800 K	step
							3-4	White 2700 K	step
							5-6	White 3200 K	step
							7-8	White 4200 K	step
							9-10	White 5600 K	step
							11-12	White 6500 K	step
							13	Blue (Blue=full, Red+Green+White/Amber=0)	step
							14-23	Red=0, Green->up,Blue =full, White/Amber=0	proportional
							24	Cyan (Red=0, Green=full, Blue =full, White/Amber=0)	step
							25-34	Red=0, Green=full, Blue->down, White/Amber=0	proportional
							35	Green (Red=0, Green=full, Blue =0, White/Amber=0)	step
							36-45	Red->up, Green=full, Blue=0, White/Amber=0	proportional
							46	Yellow (Red=full, Green=full, Blue=0, White/Amber=0)	step
							47-56	Red=full, Green->down, Blue=0, White/Amber=0	proportional
							57	Red(Red=full, Green=0, Blue=0, White/Amber=0)	step
							58-67	Red=full, Green=0, Blue->up, White/Amber=0	proportional
							68	Magenta (Red=full, Green=0, Blue=full, White/Amber=0)	step
							69-78	Red -> down, Green=0, Blue=full, White/Amber=0	proportional
							79	Blue (Red=0, Green=0, Blue=full, White/Amber=0)	step
								<b>Transition effects</b>	
							80-87	Rainbow effect (with fade time) from slow-> fast	proportional
							88-95	Rainbow effect (without fade time) from slow-> fast	proportional
							96-103	Full dynamic white (1800K->6500K->1800K) (with fade time) from slow-> fast	proportional
							104-111	Full dynamic white (1800K->6500K->1800K) (without fade time) from slow-> fast	proportional
							112-119	Dynamic warm white (1800K-3000K-1800K) (with fade time) from slow-> fast	proportional
							120-127	Dynamic warm white (1800K-3000K-1800K) (without fade time) from slow-> fast	proportional
							128-135	Rainbow effect + full dynamic white (with fade time) from slow-> fast	proportional
							136-143	Rainbow effect + full dynamic white (without fade time) from slow-> fast	proportional
							144-151	Blue/Green effect (with fade time) from slow-> fast	proportional
							152-159	Blue/Green effect (without fade time) from slow-> fast	proportional
							160-167	Red/Blue effect (with fade time) from slow-> fast	proportional
							168-175	Red/Blue effect (without fade time) from slow-> fast	proportional
							176-183	Green/Red effect (with fade time) from slow-> fast	proportional
							184-191	Green/Red effect (without fade time) from slow-> fast	proportional
							192-199	Blue/4000K effect (with fade time) from slow-> fast	proportional
							200-207	Blue/4000K effect (without fade time) from slow-> fast	proportional
							208-215	Green/4000K effect (with fade time) from slow-> fast	proportional
							216-223	Green/4000K effect (without fade time) from slow-> fast	proportional
							224-231	Red/4000K effect (with fade time) from slow-> fast	proportional
							232-239	Red/4000K effect (without fade time) from slow-> fast	proportional
							240-255	Reserved	

DMX protocol

Mode/channels							DMX Value	Function	Type of control
1	2	3	4	5	6	7			
						13		<b>Shutter/Strobe</b>	
							0-31	Shutter closed	step
							32-63	Shutter open	step
							64-95	Strobe-effect from slow to fast	proportional
							96-127	Shutter open	step
							128-143	Opening pulse in sequences from slow to fast	proportional
							144-159	Closing pulse in sequences from fast to slow	proportional
							160-191	Shutter open	step
							192-223	Random strobe-effect from slow to fast	proportional
							224-255	Shutter open	step
-	-	11	3	5	7	14		<b>Dimmer</b>	
							0-255	Light intensity coarse (0-100%)	proportional
-	-	12	-	6	8	15		<b>Dimmer Fine</b>	
							0-255	Light intensity fine	proportional
Copyright © 2022-2024 Robe Lighting s.r.o. - All rights reserved									
All Specifications subject to change without notice									

DMX protocol for: Eminere 1/2/3/4; Eminere Side 1/2/3/4; Eminere Inground 2/4; Eminere Remote 1/2/3/4; UVinere 2/4; UVinere Remote 1/2/4					
Version: 3.3 (23 modes in total)					
<b>Mode/Channels in all</b>				Mode 11: White selection, Mode 12: WW + CW	
<b>11</b>	<b>12</b>	<b>13</b>	<b>14-16</b>	Mode 13: Only dimmer	
3	4	2	Reserved	<i>Mode 13 is suitable for UVinere and UVinere Remote</i>	
<b>TW and PW modes</b>					
Mode/channels			DMX Value	Function	Type of control
11	12	13			
1	-	-	0 - 255	<b>White colour selection</b> White from 2700 K - 6500 K	proportional
-	1	-	0 - 255	<b>Warm White</b> Warm White LEDs saturation control (0-100%)	proportional
-	2	-	0 - 255	<b>Cool White</b> Cool White LEDs saturation control (0-100%)	proportional
2	3	1	0 - 255	<b>Dimmer</b> Light intensity coarse (0 - 100%)	proportional
3	4	2	0 - 255	<b>Dimmer Fine</b> Light intensity fine	proportional
Copyright © 2022-2024 Robe Lighting s.r.o. - All rights reserved					
All Specifications subject to change without notice					

**DMX protocol for: Eminere 1/2/3/4; Eminere Side 1/2/3/4;  
Eminere Inground 2/4; Eminere Remote 1/2/3/4;**

Version: 3.3 (23 modes in total)

Mode/Channels in all					Mode 17: RGBW(A) pixels, Mode 18: RGB pixels, Mode 19: TW pixels, Mode 20: PW dimmer pixels			
17	18	19	20	21-23				
16	12	8	8	Reserved				
Mode/channels					DMX Value	Pixel modes	Function	Type of control
17	18	19	20					
1	1	-	-	0 - 255	<b>Red 1 -Eminere 1/2/3/4</b>	Red LEDs saturation control (0-100%)	proportional	
2	2	-	-	0 - 255	<b>Green 1-Eminere 1/2/3/4</b>	Green LEDs saturation control (0-100%)	proportional	
3	3	-	-	0 - 255	<b>Blue 1-Eminere 1/2/3/4</b>	Blue LEDs saturation control (0-100%)	proportional	
4	-	-	-	0 - 255	<b>White (Amber) 1-Eminere 1/2/3/4</b>	White LEDs saturation control (0-100%)	proportional	
5	4	-	-	0 - 255	<b>Red 2 -Eminere 2/3/4</b>	Red LEDs saturation control (0-100%)	proportional	
6	5	-	-	0 - 255	<b>Green 2-Eminere 2/3/4</b>	Green LEDs saturation control (0-100%)	proportional	
7	6	-	-	0 - 255	<b>Blue 2-Eminere 2/3/4</b>	Red LEDs saturation control (0-100%)	proportional	
8	-	-	-	0 - 255	<b>White (Amber) 2-Eminere 2/3/4</b>	White LEDs saturation control (0-100%)	proportional	
9	7	-	-	0 - 255	<b>Red 3-Eminere 3/4</b>	Red LEDs saturation control (0-100%)	proportional	
10	8	-	-	0 - 255	<b>Green 3-Eminere 3/4</b>	Green LEDs saturation control (0-100%)	proportional	
11	9	-	-	0 - 255	<b>Blue 3-Eminere 3/4</b>	Blue LEDs saturation control (0-100%)	proportional	
12	-	-	-	0 - 255	<b>White (Amber) 3-Eminere 3/4</b>	White LEDs saturation control (0-100%)	proportional	
13	10	-	-	0 - 255	<b>Red 4-Eminere 4</b>	Red LEDs saturation control (0-100%)	proportional	
14	11	-	-	0 - 255	<b>Green 4-Eminere 4</b>	Green LEDs saturation control (0-100%)	proportional	
15	12	-	-	0 - 255	<b>Blue 4-Eminere 4</b>	Blue LEDs saturation control (0-100%)	proportional	
16	-	-	-	0 - 255	<b>White (Amber) 4 -Eminere 4</b>	White LEDs saturation control (0-100%)	proportional	
-	-	1	-		<b>Warm White 1 -Eminere 1/2/3/4</b>	Warm White LEDs saturation control (0-100%)	proportional	
-	-	2	-	0 - 255	<b>Cool White 1-Eminere 1/2/3/4</b>	Cool White LEDs saturation control (0-100%)	proportional	
-	-	3	-		<b>Warm White 2-Eminere 2/3/4</b>			

DMX protocol

Mode/channels				DMX Value	Function	Type of control
17	18	19	20			
				0 - 255	Warm White LEDs saturation control (0-100%)	proportional
-	-	4	-	0 - 255	<b>Cool White 2-Eminere 2/3/4</b> Cool White LEDs saturation control (0-100%)	proportional
-	-	5	-	0 - 255	<b>Warm White 3-Eminere 3/4</b> Warm White LEDs saturation control (0-100%)	proportional
-	-	6	-	0 - 255	<b>Cool White 3-Eminere 3/4</b> Cool White LEDs saturation control (0-100%)	proportional
-	-	7	-	0 - 255	<b>Warm White 4 -Eminere 4</b> Warm White LEDs saturation control (0-100%)	proportional
-	-	8	-	0 - 255	<b>Cool White 4 -Eminere 4</b> Cool White LEDs saturation control (0-100%)	proportional
-	-	-	1	0 - 255	<b>Dimmer 1</b> Light intensity coarse (0 - 100%)	proportional
-	-	-	2	0 - 255	<b>Dimmer Fine 1</b> Light intensity fine	proportional
-	-	-	3	0 - 255	<b>Dimmer 2</b> Light intensity coarse (0 - 100%)	proportional
-	-	-	4	0 - 255	<b>Dimmer Fine 2</b> Light intensity fine	proportional
-	-	-	5	0 - 255	<b>Dimmer 3</b> Light intensity coarse (0 - 100%)	proportional
-	-	-	6	0 - 255	<b>Dimmer Fine 3</b> Light intensity fine	proportional
-	-	-	7	0 - 255	<b>Dimmer 4</b> Light intensity coarse (0 - 100%)	proportional
-	-	-	8	0 - 255	<b>Dimmer Fine 4</b> Light intensity fine	proportional
Copyright © 2022-2024 Robe Lighting s.r.o. - All rights reserved						
All Specifications subject to change without notice						

## DMX protocol for Calumma - All sizes - MC and SC

Version: 1.3 (16 modes in total)

Mode/Channels in all								Mode 1- RGBW(A)-8bit, Mode 2- RGB 8-bit, Mode 3- full RGBW(A)	
1	2	3	4	5	6	7	8-10	Mode 4- White-full control, Mode 5- Reduced RGBW(A)	
4	3	12	3	6	8	15	Reserved	Mode 6- Reduced RGBW(A)+white control, Mode 7- Full control	
								Mode 7-Full RGBW(A)+virt. Colour wheel	
								RGBW/RGBA/RGB modes	
Mode/channels							DMX Value	Function	Type of control
1	2	3	4	5	6	7			
-	-	-	-	-	-	1		<b>Special functions</b>	
							0	No function	step
								<i>To activate following functions , stop in DMX value for at least 3 sec.</i>	
							1-2	Save current DMX values to fixture as initial DMX values.	step
							3-4	Show saved initial DMX values	step
							5-6	Run factory demo sequences at switching fixture on (without DMX)	step
							7-8	Insect friendly light On (RGBA version only)	step
							9-10	Insect friendly light Off (RGBA version only)	step
							11-255	Reserved	
1	1	1	-	1	1	2		<b>Red</b>	
							0 - 255	Red LEDs saturation control (0-100%)	proportional
-	-	2	-	-	-	3		<b>Red Fine</b>	
							0 - 255	Red LEDs saturation control fine	proportional
2	2	3	-	2	2	4		<b>Green</b>	
							0 - 255	Green LEDs saturation control (0-100%)	proportional
-	-	4	-	-	-	5		<b>Green Fine</b>	
							0 - 255	Green LEDs saturation control fine	proportional
3	3	5	-	3	3	6		<b>Blue</b>	
							0 - 255	Blue LEDs saturation control (0-100%)	proportional
-	-	6	-	-	-	7		<b>Blue Fine</b>	
							0 - 255	Blue LEDs saturation control fine	proportional
4	-	7	-	4	4	8		<b>White (Amber)</b>	
							0 - 255	White LEDs saturation control (0-100%)	proportional
-	-	8	-	-	-	9		<b>White (Amber) Fine</b>	
							0 - 255	White LEDs saturation control fine	proportional
-	-	9	1	-	5	10		<b>Green correction</b>	
							0	Uncorrected white	step
							1-127	Minus green - uncorrected white	proportional
							128	Uncorrected white (128=default)	step
							129-255	Uncorrected white - Plus green	proportional
-	-	10	2	-	6	11		<b>Colour temperature correction (CTC)</b>	
							0	No function	step
							1 - 10	Tungsten dimming 2700 K	step
							11 - 20	Tungsten dimming 3200 K	step
							21-255	Colour temperature changing from 1800 K --> 6500 K (21-1800K, 66-2700K, 91-3200K,141-4200K, 211-5600K, 255-6500K)	proportional
-	-	-	-	-	-	12		<b>Virtual Colour Wheel</b>	
							0	No function	step

DMX protocol

Mode/channels							DMX Value	Function	Type of control
1	2	3	4	5	6	7			
							1-2	White 1800 K	step
							3-4	White 2700 K	step
							5-6	White 3200 K	step
							7-8	White 4200 K	step
							9-10	White 5600 K	step
							11-12	White 6500 K	step
							13	Blue (Blue=full, Red+Green+White/Amber=0)	step
							14-23	Red=0, Green->up,Blue =full, White/Amber=0	proportional
							24	Cyan (Red=0, Green=full, Blue =full, White/Amber=0)	step
							25-34	Red=0, Green=full, Blue->down, White/Amber=0	proportional
							35	Green (Red=0, Green=full, Blue =0, White/Amber=0)	step
							36-45	Red->up, Green=full, Blue=0, White/Amber=0	proportional
							46	Yellow (Red=full, Green=full, Blue=0, White/Amber=0)	step
							47-56	Red=full, Green->down, Blue=0, White/Amber=0	proportional
							57	Red(Red=full, Green=0, Blue=0, White/Amber=0)	step
							58-67	Red=full, Green=0, Blue->up, White/Amber=0	proportional
							68	Magenta (Red=full, Green=0, Blue=full, White/Amber=0)	step
							69-78	Red -> down, Green=0, Blue=full, White/Amber=0	proportional
							79	Blue (Red=0, Green=0, Blue=full, White/Amber=0)	step
								<b>Transition effects</b>	
							80-87	Rainbow effect (with fade time) from slow-> fast	proportional
							88-95	Rainbow effect (without fade time) from slow-> fast	proportional
							96-103	Full dynamic white (1800K->6500K->1800K) (with fade time) from slow-> fast	proportional
							104-111	Full dynamic white (1800K->6500K->1800K) (without fade time) from slow-> fast	proportional
							112-119	Dynamic warm white (1800K-3000K-1800K) (with fade time) from slow-> fast	proportional
							120-127	Dynamic warm white (1800K-3000K-1800K) (without fade time) from slow-> fast	proportional
							128-135	Rainbow effect + full dynamic white (with fade time) from slow-> fast	proportional
							136-143	Rainbow effect + full dynamic white (without fade time) from slow-> fast	proportional
							144-151	Blue/Green effect (with fade time) from slow-> fast	proportional
							152-159	Blue/Green effect (without fade time) from slow-> fast	proportional
							160-167	Red/Blue effect (with fade time) from slow-> fast	proportional
							168-175	Red/Blue effect (without fade time) from slow-> fast	proportional
							176-183	Green/Red effect (with fade time) from slow-> fast	proportional
							184-191	Green/Red effect (without fade time) from slow-> fast	proportional
							192-199	Blue/4000K effect (with fade time) from slow-> fast	proportional
							200-207	Blue/4000K effect (without fade time) from slow-> fast	proportional
							208-215	Green/4000K effect (with fade time) from slow-> fast	proportional
							216-223	Green/4000K effect (without fade time) from slow-> fast	proportional
							224-231	Red/4000K effect (with fade time) from slow-> fast	proportional
							232-239	Red/4000K effect (without fade time) from slow-> fast	proportional
						<b>13</b>		<b>Shutter/Strobe</b>	
							0-31	Shutter closed	step
							32-63	Shutter open	step
							64-95	Strobe-effect from slow to fast	proportional

DMX protocol

Mode/channels							DMX Value	Function	Type of control
1	2	3	4	5	6	7			
							96-127	Shutter open	step
							128-143	Opening pulse in sequences from slow to fast	proportional
							144-159	Closing pulse in sequences from fast to slow	proportional
							160-191	Shutter open	step
							192-223	Random strobe-effect from slow to fast	proportional
							224-255	Shutter open	step
-	-	11	3	5	7	14		<b>Dimmer</b>	
							0 - 255	Light intensity coarse (0-100%)	proportional
-	-	12	-	6	8	15		<b>Dimmer Fine</b>	
							0 - 255	Light intensity fine	proportional
Copyright © 2022-2024 Robe Lighting s.r.o. - All rights reserved									
All Specifications subject to change without notice									

<b>DMX protocol for Calumma - All sizes - MC and SC</b>					
Version: 1.3 (16 modes in total)					
<b>Mode/Channels in all</b>				<b>TW Modes: Mode 11- White selection + Dimmer, Mode 12- WW + CW</b>	
<b>11</b>	<b>12</b>	<b>13</b>	<b>14-16</b>	<b>PW Mode: Mode 13- Dimmer</b>	
3	4	2	Reserved		
<b>TW and PW modes</b>					
<b>Mode/channels</b>			<b>DMX Value</b>	<b>Function</b>	<b>Type of control</b>
<b>11</b>	<b>12</b>	<b>13</b>			
<b>1</b>	-	-	0 - 255	<b>White colour selection</b> White from 2700 K - 6500 K	proportional
-	<b>1</b>	-	0 - 255	<b>Warm White</b> Warm White LEDs saturation control (0-100%)	proportional
-	<b>2</b>	-	0 - 255	<b>Cool White</b> Cool White LEDs saturation control (0-100%)	proportional
<b>2</b>	<b>3</b>	<b>1</b>	0 - 255	<b>Dimmer</b> Light intensity coarse (0 - 100%)	proportional
<b>3</b>	<b>4</b>	<b>2</b>	0 - 255	<b>Dimmer Fine</b> Light intensity fine	proportional
Copyright © 2022-2024 Robe Lighting s.r.o. - All rights reserved					
All Specifications subject to change without notice					