

# E-box Remote Basic Mini

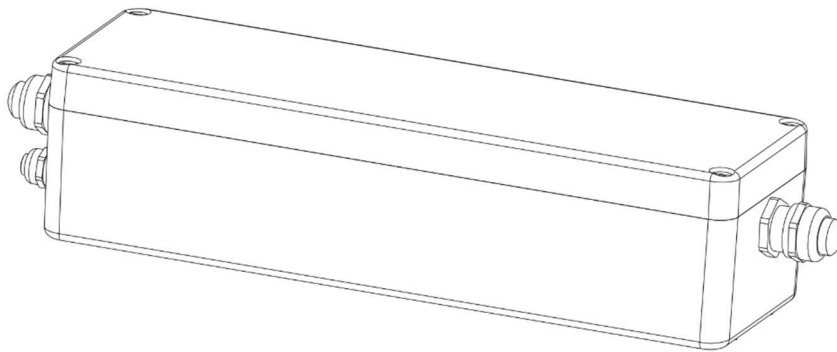

QR code for user manual



# E-box Remote Basic Mini

## Table of contents

1. Safety information .....	4
2. Fixture description .....	6
3. Mounting .....	8
4. RDM manager .....	11
5. Software update of connected LED modules .....	16
6. Technical specifications.....	17
7. Disposing of the product .....	18
8. Change Log .....	18

# 1. Safety information

**FOR YOUR OWN SAFETY, PLEASE READ THIS USER MANUAL CAREFULLY  
BEFORE POWERING OR INSTALLING YOUR E-BOX REMOTE BASIC 240W!  
Save it for future reference.**

**DANGEROUS VOLTAGE CONSTITUTING A RISK OF ELECTRIC SHOCK IS PRESENT WITHIN THIS UNIT!**

Make sure that the available voltage is not higher than stated on the fixture. Always disconnect the fixture from AC power before removing its cover.

Make sure that the supply cables are not damaged by sharp edges. Check the fixture and the cables from time to time.

Do not install the fixture near an open flame.

This fixture falls under protection class I. Therefore, this fixture has to be connected to a mains socket outlet with a protective earthing connection.

Do not connect this fixture to a dimmer pack.

Do not cover the fixture with cloth or other materials.

The fixture is designed for outdoor use and it is intended for professional application only. It is not for household use.

When choosing the installation spot, please make sure that the fixture is not exposed to extreme heat or dust.

Only operate the fixture after having checked that the housing is firmly closed and all screws are tightly fastened.

Operate the fixture only after having familiarized yourself with its functions. Do not permit operation by persons not qualified to operate the fixture. Most damages are the result of unprofessional operation!

Please consider that unauthorized modifications on the fixture are forbidden due to safety reasons! Please use the original packaging if the fixture is to be transported.

If this device will be operated in any way different to the one described in this manual, the product may suffer damages and the warranty becomes void. Furthermore, any other operation may lead to dangers like short-circuit, burns, electric shock etc.

The product (covers and cables) must not be exposed to a high frequency electromagnetic field higher than 3V/m.

Immunity of the equipment is designed according to the standard EN 55035 Electromagnetic compatibility of multimedia equipment - Immunity requirements

Emission of the equipment complies with the standard EN55032 Electromagnetic compatibility of multimedia equipment – Emission Requirements according to class B.

This device complies with part 15 of the FCC Rules. Operation is subject to the following two conditions: (1) This device may not cause harmful interference, and (2) this device must accept any interference received, including interference that may cause undesired operation.

Changes or modifications not expressly approved by the party responsible for compliance could void the user's authority to operate the equipment.

The [Device] wireless operation is safe and complies to RF Exposure requirements.

This equipment has been tested and found to comply with the limits for a Class B digital device, pursuant to part 15 of the FCC Rules. These limits are designed to provide reasonable protection against harmful interference in a residential installation. This equipment generates, uses and can radiate radio frequency energy and, if not installed and used in accordance with the instructions, may cause harmful interference to radio communications. However, there is no guarantee that interference will not occur in a particular installation. If this equipment does cause harmful interference to radio or television reception, which can be determined by turning the equipment

off and on, the user is encouraged to try to correct the interference by one or more of the following measures:

- Reorient or relocate the receiving antenna.
- Increase the separation between the equipment and receiver.
- Connect the equipment into an outlet on a circuit different from that to which the receiver is connected.
- Consult the dealer or an experienced radio/TV technician for help.

**ATTENTION!**

**Risque de choc. Couper L'alimentation avant L'entretien.**

**Non destine a à un usage domestique**

Convient aux emplacements mouillés.

Ce produit doit être installé selon le code d'installation pertinent, par une personne qui connaît bien le produit et son fonctionnement ainsi que les risques inhérents.

## 2. Fixture description



View without top cover

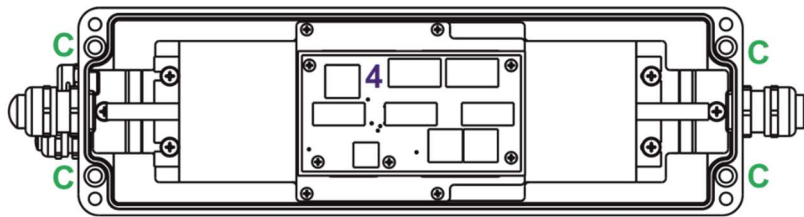

- A - Top cover
- B - Top cover fastening screws
- C - Mounting holes

- 1 - LED Output (cable gland M20x1.5)
- 2 - Power IN (cable gland M20x1.5)
- 3 - DMX IN (cable gland M12x1.5)
- 4 - Connection board (RB4190)

Connection points

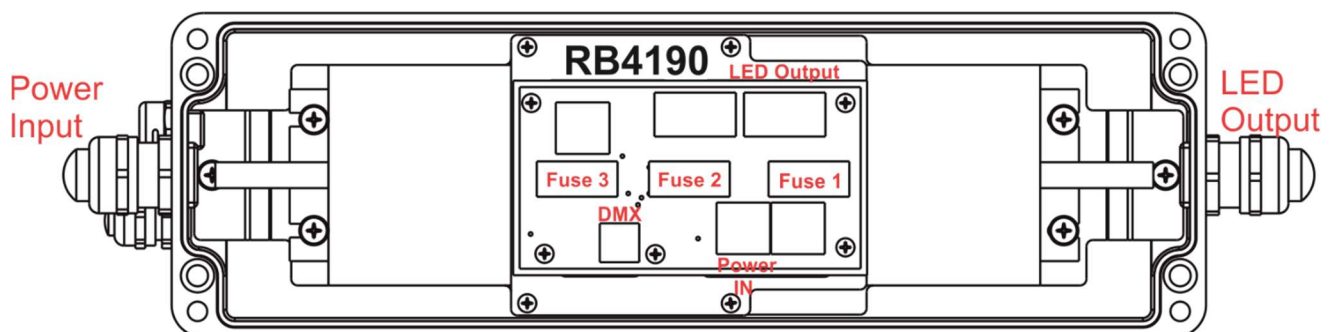

Detail of PCB RB4190

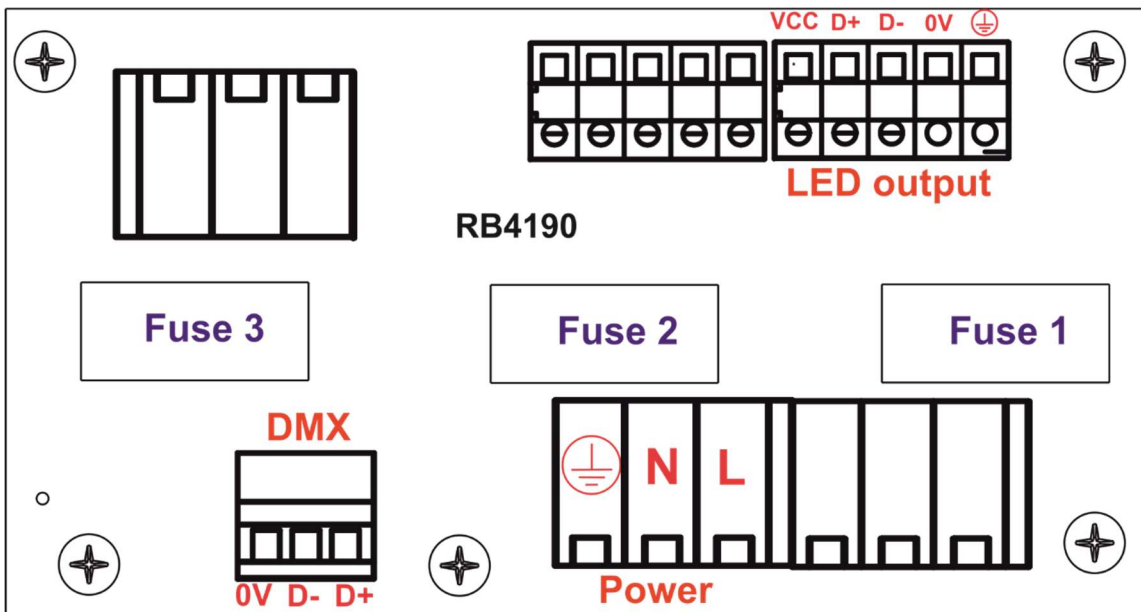

- Fuse 1 T 6.3A/500V AC
- Fuse 2 T 8A/250V AC
- Fuse 3 T 8A/250V AC

### 3. Mounting

**Fixture must be installed by a qualified electrician in accordance with all national and local electrical and construction codes and regulations.**

**Connecting the E-BOX REMOTE BASIC 240W can be done by a qualified person only!**



**Note for cable glands.**

We recommend applying an adequate layer of the paste LOCTITE 5331 on the plastic holder of the cable gland before inserting it into the body of the gland.

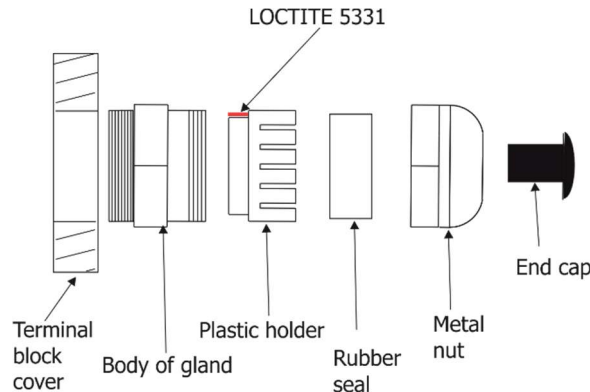

1. Remove the top cover (A) from the E-box Remote Basic Mini by unscrewing four fastening screws (B) in order to get access to terminals.
2. Fasten the E-box Remote Basic Mini on a non-flammable flat surface via four mounting holes (C) of a diameter of 6.5 mm in its housing.
3. Remove end caps from cable glands before passing cables. To keep declared IP rating of the device, every cable gland has to be covered with the end cap if the cable gland is not used.

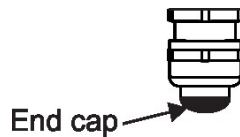

5. Pass cable for DMX through the cable glands M12x1.5 and connect it to the terminal block and tighten the cable in the cable gland.
6. Pass cables for Power and LED outputs through cable glands M20x1.5 and connect them to the terminal blocks and tighten the cables in the cable glands.

Cable glands serve for cables of the following diameters:

Cable gland M12x1.5 (DMX IN/OUT, Ethernet IN/OUT) - for cable of a diameter of 3-7mm.

Cable gland M20x1.5 (Power IN, LED Output) - for cable of a diameter of 7-13mm. For smaller diameter of cable (4-8mm) you have to remove original seal from the cable gland M20 and use reducing seal (P/N 13051388) instead of it. Reducing seal is enclosed to the product.

Check that all screws and cable glands are firmly tightened.

7. Screw the top cover (A) back on the box.

**ALWAYS DISCONNECT THE E-BOX REMOTE BASIC 240W FROM MAINS BEFORE CONNECTING/DISCONNECTING LED MODULES**

**This device falls under protection class I. Therefore, every E-box Remote Basic 240W**

**Power connection**

	<b>L</b>	<b>N</b>	
Core (CE)	Brown	Blue	Green/yellow
Core (US)	Black	White	Green

**DMX connection**

<b>D+</b>	<b>D-</b>	<b>0V</b>
Data +	Data -	Data ground (shielding)

## Eminere Remote connection

CE version:

Mark	Function	Wire
Vcc	LEDs +	Red
D+	DATA +	Orange
D-	DATA -	White
0V	LEDS -	Black
	Ground	Not connected

US version:

Mark	Function	Wire
Vcc	LEDs +	Red
D+	DATA +	Orange
D-	DATA -	White
0V	LEDS -	Black
	Ground	Green

Example of connection

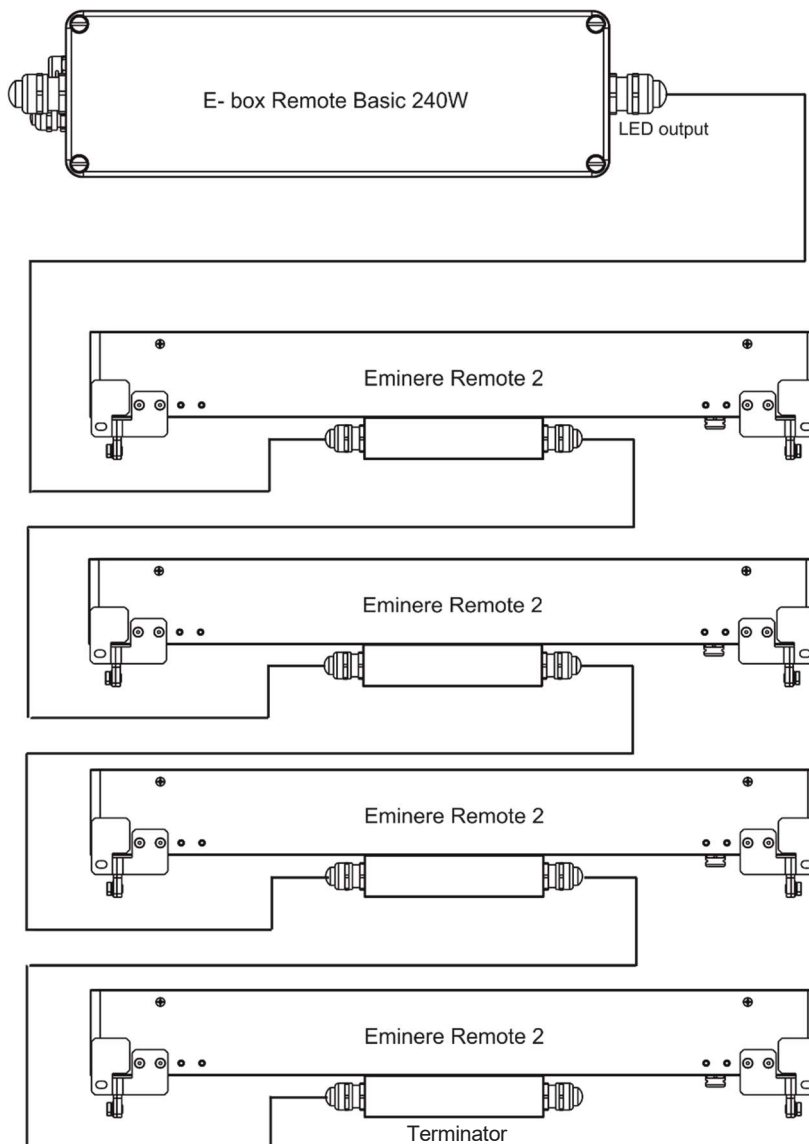



Each line of Emineres Remote connected to the LED output of the E-box Remote Basic Mini has to be terminated at the last fixture.

**EITHER** connect a 120 Ohm resistor between terminals D+ and D- as shown, **OR** terminate via RDM as described on page 14.



Ensure **ONLY** the last fixture in the line is terminated using **ONE** of the above methods!

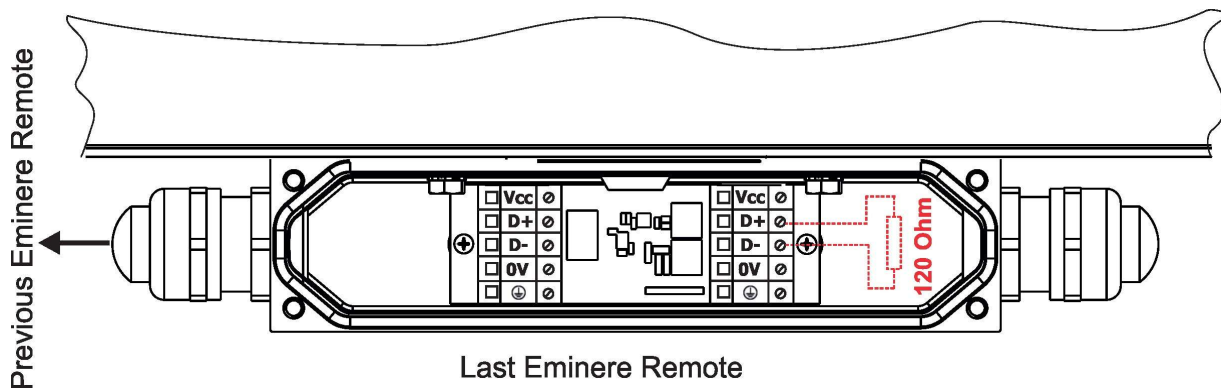

The number of Emineres Remote connected to one LED output of the E-box Remote Basic Mini depends on the type of Eminere Remote and cable length.

The table states max. number of Emineres Remote connected to the E-box Remote Basic Mini.

Cable length *	Max. number of Emineres Remote connected to the E-box Remote Basic Mini			
	Eminere Remote 1	Eminere Remote 2 (UV)	Eminere Remote 3	Eminere Remote 4 (UV)
25 m	10	5	3	2
50 m	8	4	2	2
75 m	6	3	2	1
100 m	5	2	1	1

\* Cable length is the total cable length between E-box Remote Basic Mini and last connected Eminere Remote. Example: Total cable length=L1+L2+L3.

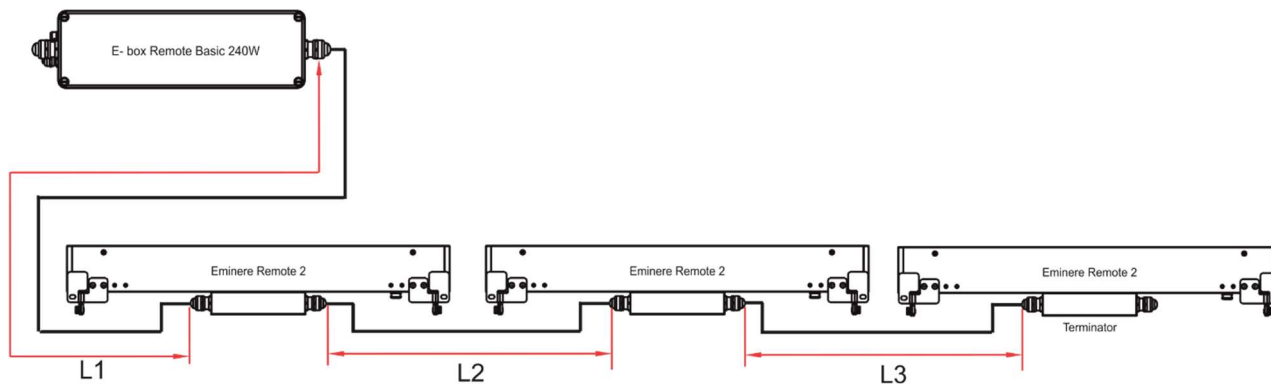

## 4.RDM manager

The RDM manager allows you to read information about connected LED modules and set their behaviour. The Emineres Remote can be controlled in the Pass Through mode only.



RDM Manager and DMX controller cannot be connected at the same time.

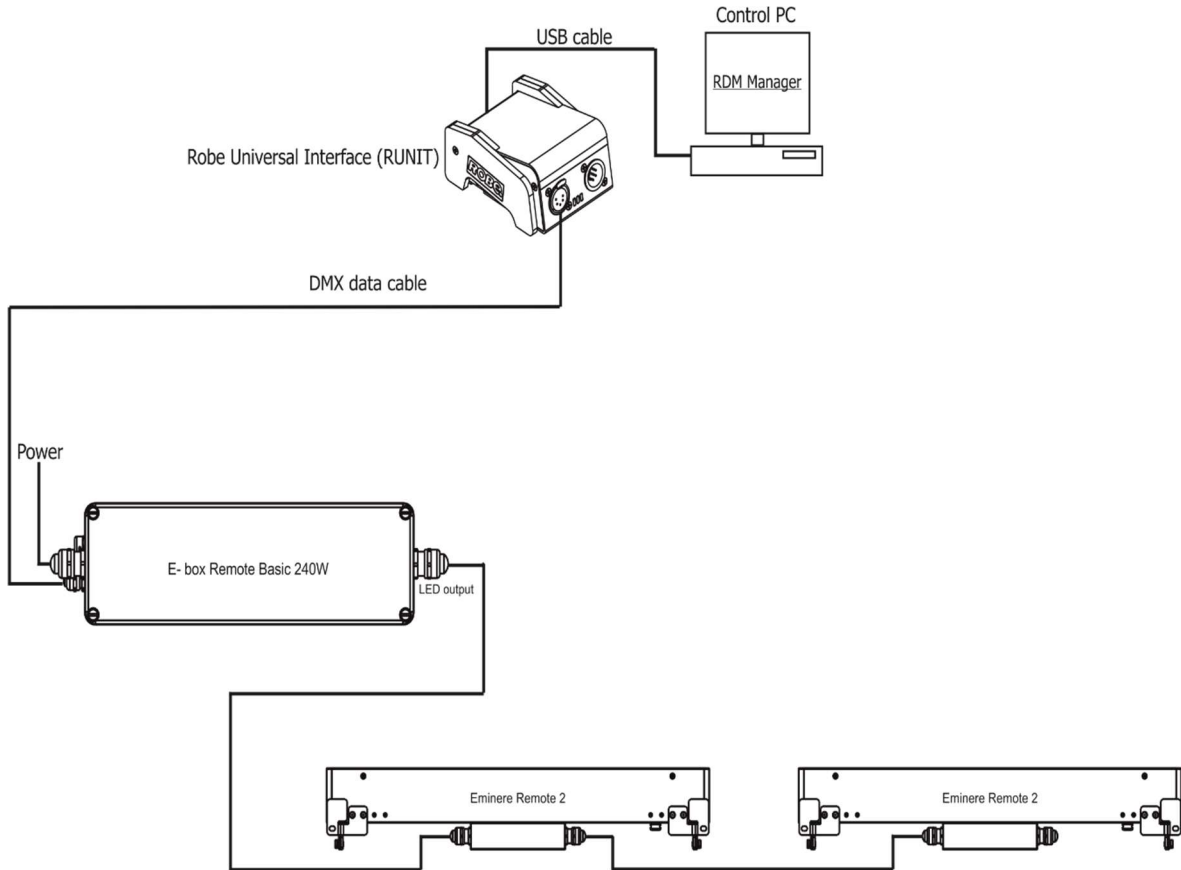

## Examples of RDM manager screenshots.

Initial screen of the RDM manager – Pass Through mode:

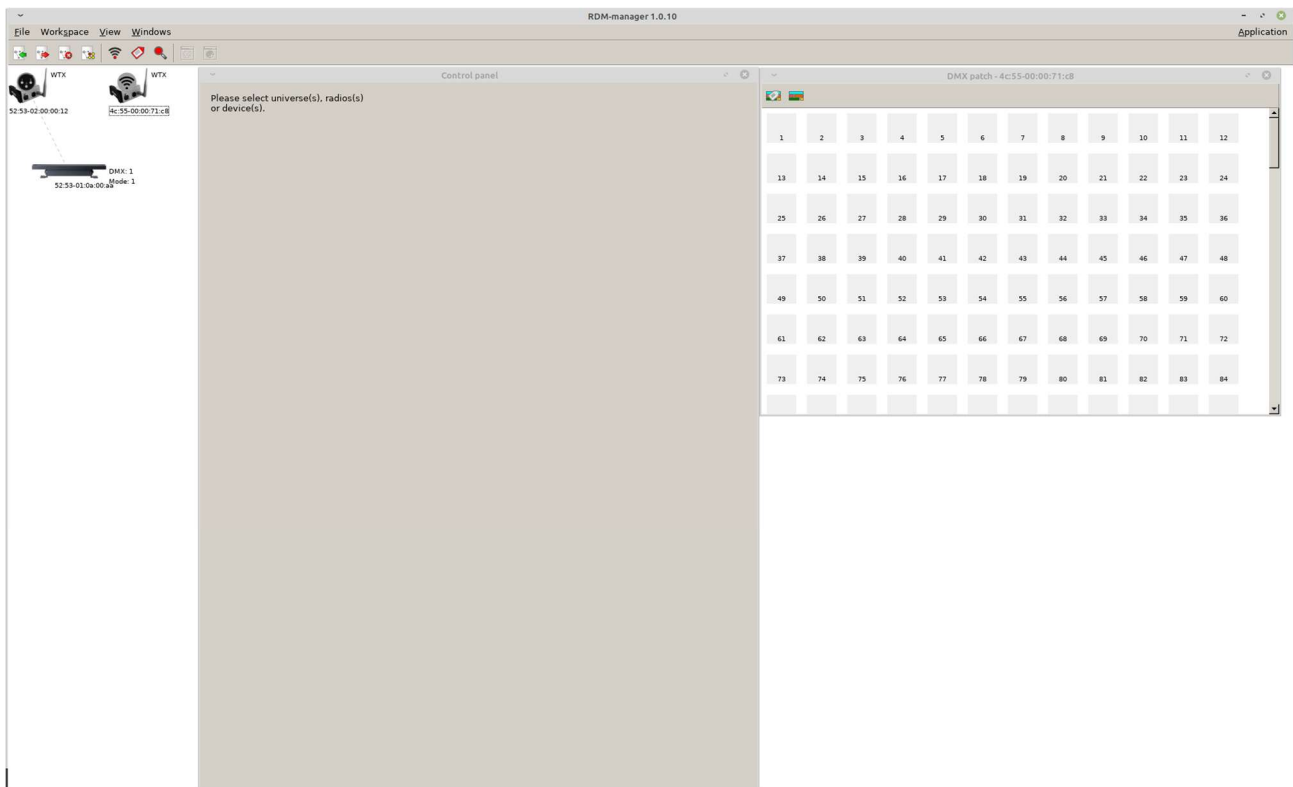

Click on the LED device to show and set options in the Control panel:

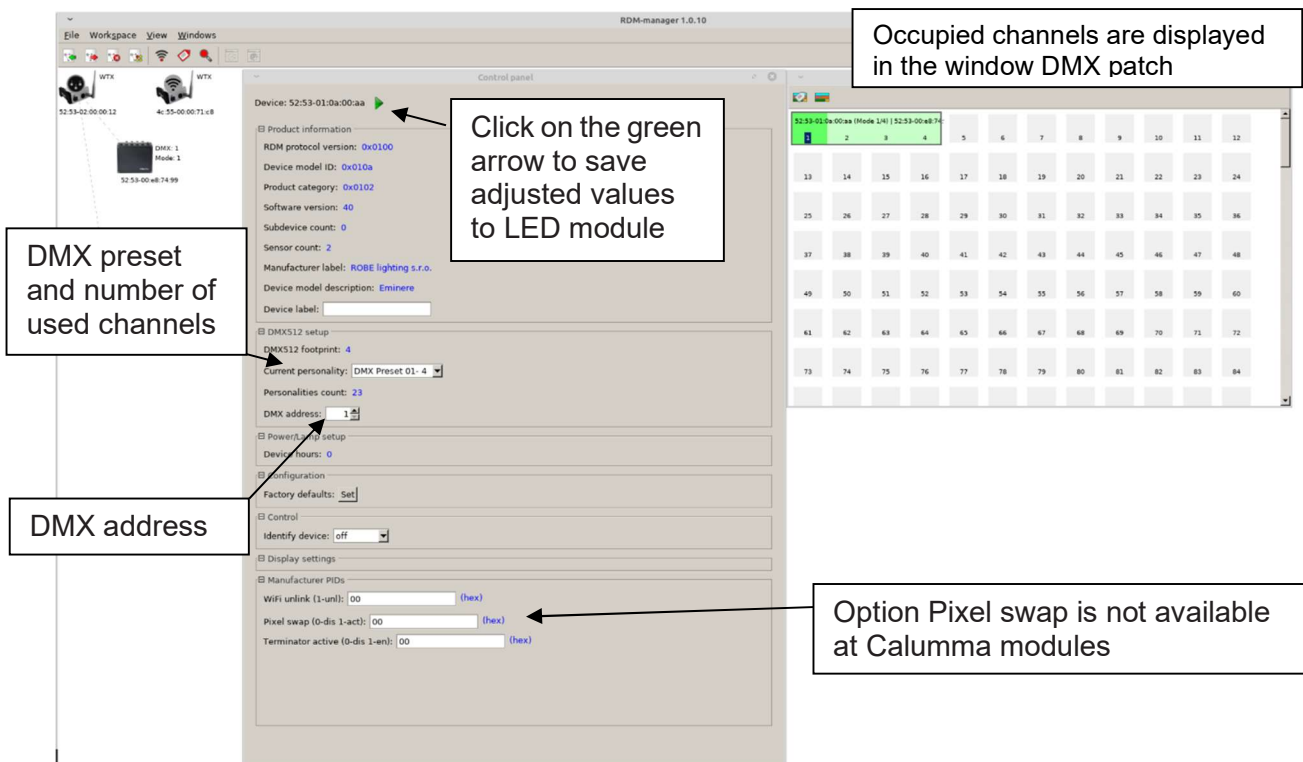

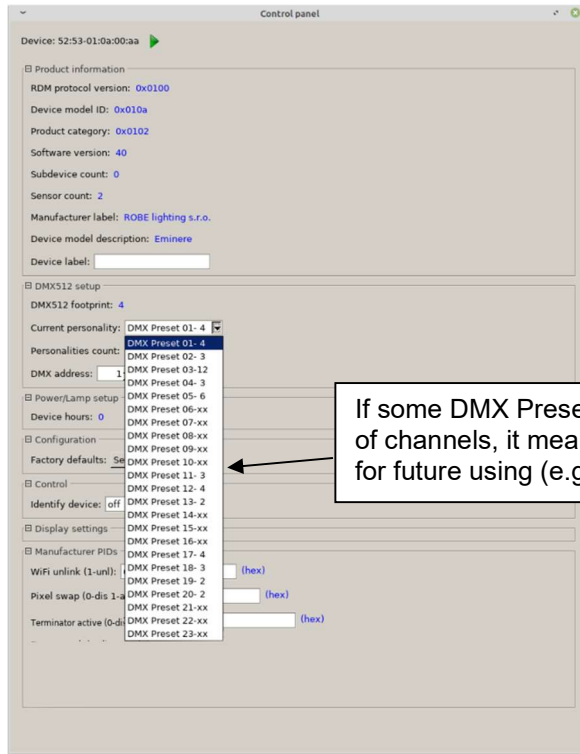

Options in the control panel:

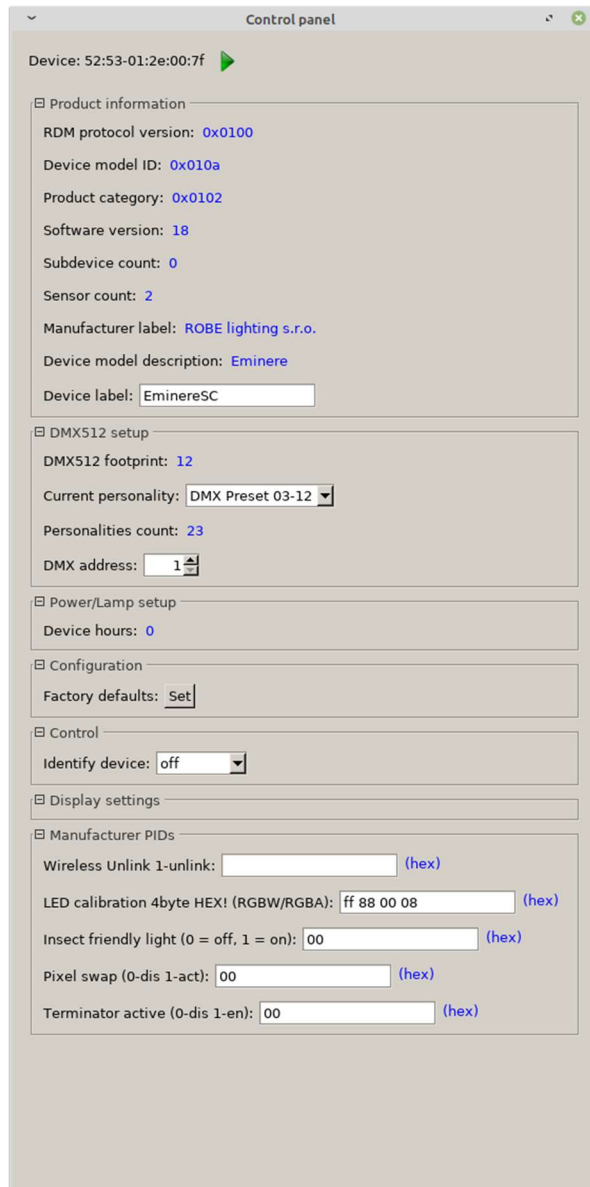

## Manufacturer PIDs

Wireless unlink - the item allows you to unlink the Eminere from a DMX transmitter (Wireless DMX version of the Eminere only).

LED calibration 4byte HEX! (RGBW/RGBA) - the item shows 4 bytes of calibration values for calibrated white colours of RGBW(RGBA) Eminere.

E.g.



CTC channel has to be set to some calibrated white colour (21 DMX-1800K, 66 DMX-2700K, 91 DMX-3200K, 141 DMX-4200K, 211 DMX-5600K, 255 DMX-6500K) otherwise the item shows values

"ff ff ff ff" (and calibration values cannot be saved to the Eminere).

### **Warning!**

**Changing and saving values in this item will effect calibrated white colour(s) of the Eminere .**

Insect friendly light - the item effects RGBA Eminere only. If the item is on, blue colour is not used in calibrated white colours. This modification of white lights results in a smaller attraction of white light for insects (mosquitos, moths..). The function is also available from DMX chart (channel Special Function, range 7-10 DMX).

Pixel Swap – the item allows you to swap the pixel order (for Eminere 2/3/4 only).

Terminator active - the item allows you to terminate line of Emineres at last Eminere.



Last Eminere on each DMX line may be terminated by setting the 'Manufacturer PID' 'Terminator active' to '1'.

But ensure that the fixture is not already terminated with a 120 Ohm resistor as described on page 10. Last Eminere on each DMX line may be terminated by setting the 'Manufacturer PID' 'Terminator active' to "1".



The option "Pixel swap" from RDM control panel allows you to swap a pixel order.

Example:

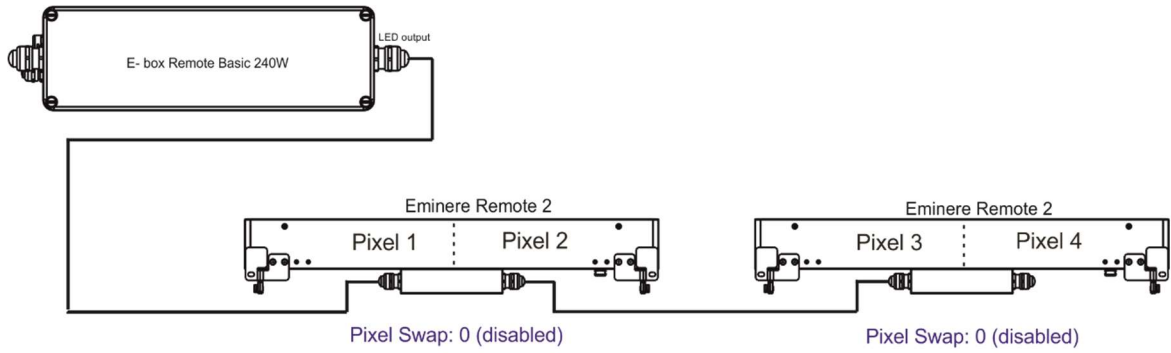

In case of reconnecting the E-box Remote Basic 240W on the other end of Emineres Remote line, the pixel order is not in succession:

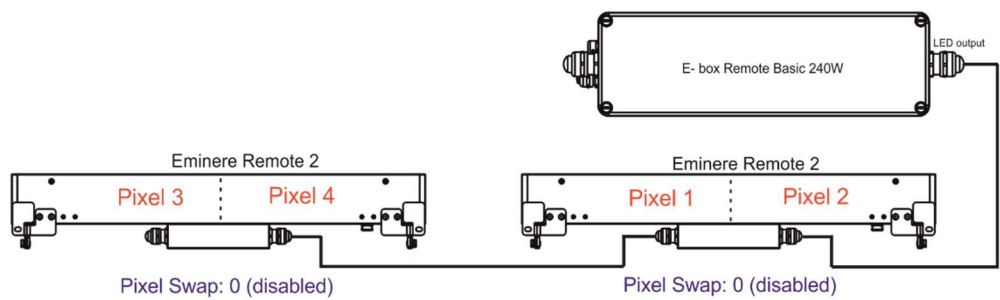

By means of the function "Pixel swap" you can rearrange pixels order.

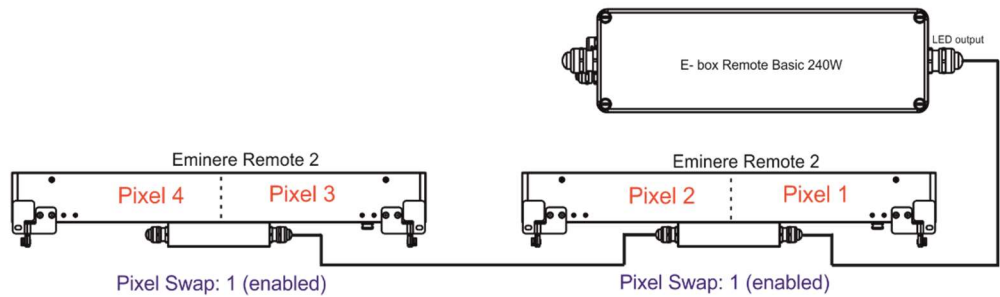

## 5. Software update of connected LED modules

The software update of connected LED modules can be done by the Robe Universal Interface (or Robe Universal Interface WTX), DMX connection and the ROBE RDM Uploader software. The ROBE Uploader is a software for automatized software update of ROBE fixtures. Please see <https://www.robe.cz/robe-uploader/> for more information about the ROBE Uploader.



**After updating Emineres Remote from older version to version 4.0, the Emineres Remote will be set to default (factory) values including DMX presets and addresses! Setting of Calumma XS modules will not be changed.**

**Update from version 4.0 to newer version will not affect setting of connected Eminere Remotes and Calummas XS.**

**Version of the Robe uploader has to be 4.16 and higher!**

You have to use the file Eminere.lib for Emineres Remote update or Calumma.lib for Calummas XS update in the ROBE Uploader.

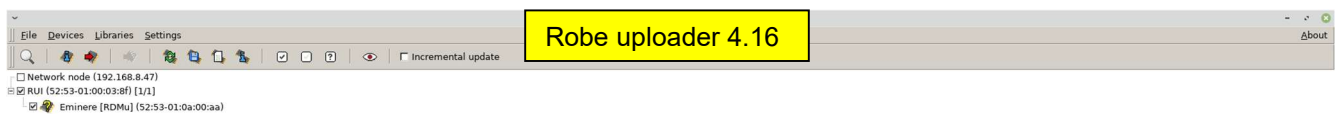

In case of combination of Emineres Remote and Calummas XS, update Emineres Remote using file Eminere.lib and after that update Calummas XS using file Calumma.lib.

Examples of connection for software update of LED modules.

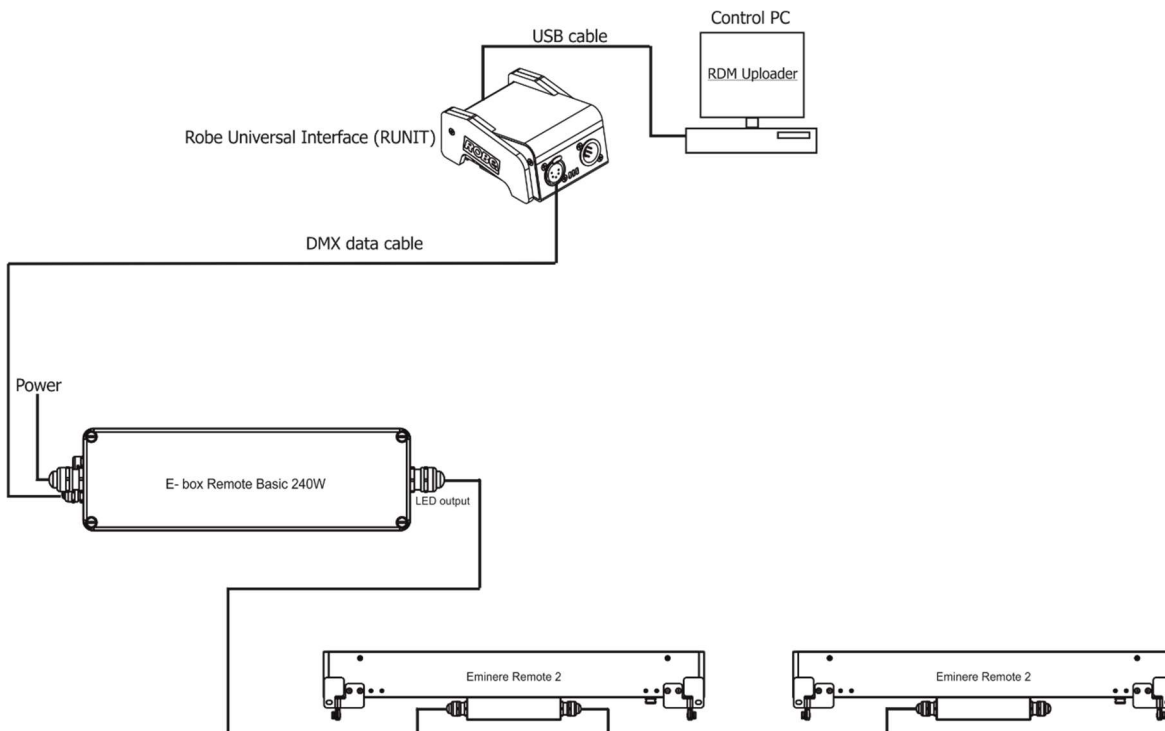

## 6. Technical specifications

Input voltage	120-240 V AC; 277V AC
Frequency	50/60Hz
Power consumption	260W
Inrush current (Typ.)	75A/230V (cold start)
Fuse 1	T 6.3A/500V AC
Fuse 2	T 8A/250V AC
Fuse 3	T 8A/250V AC
LED Output	
Number of outputs	1
Voltage	48V DC
Max output power	240W
Connection	
Power	terminal block
DMX	terminal block
LED Output	terminal block
Operating ambient temperature range	-20/+40°C (-4°F / +104°F)
Cooling System	convection
Protection factor	IP66 (CE), Suitable for Wet Locations (US)
IK Rating	IK09
Weight:	2.8 kg (6.2 lbs)

Dimensions  
mm [inch]

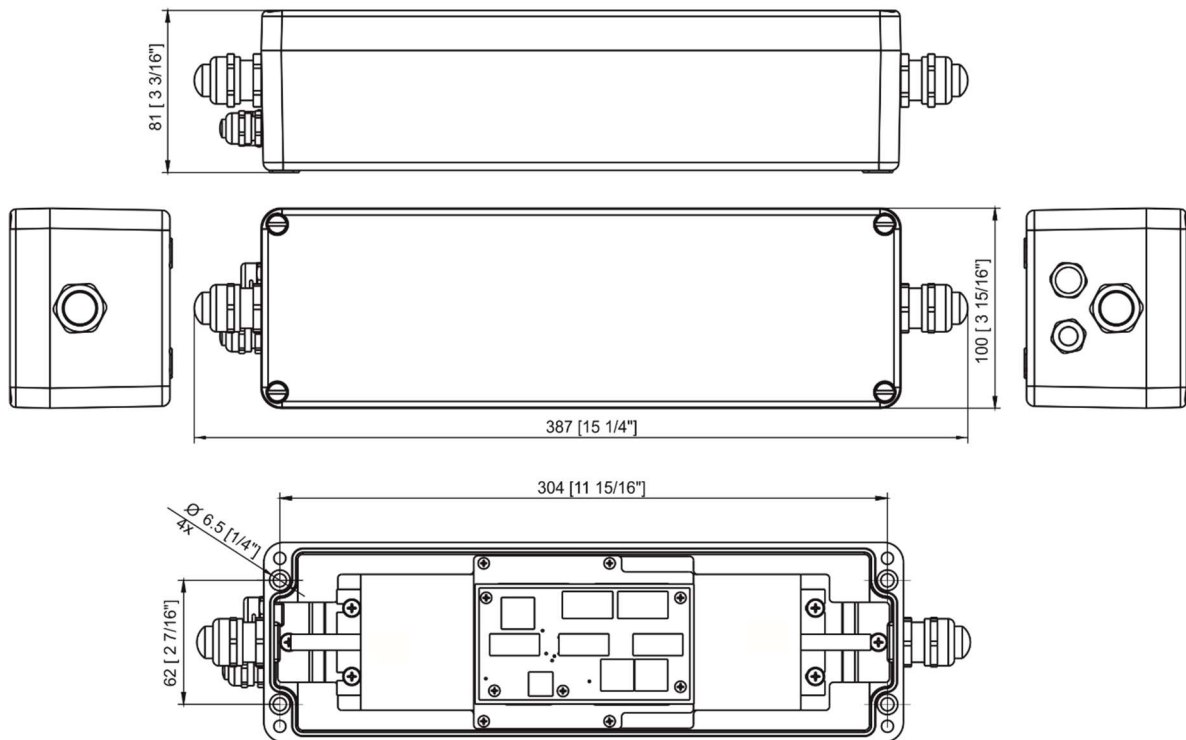

### Included items

- 1 x E-box Remote Basic Mini
- 1 x Reducing seal (P/N 13051388)
- 1 x User manual



## 7. Disposing of the product

To preserve the environment please dispose or recycle this product at the end of its life according to the local regulations and codes.

## 8. Change Log

This section summarizes changes in the user manual.

<b>Version of the manual</b>	<b>Date of issue</b>	<b>Description of changes</b>
1.1	30/06/2023	Device renamed
1.2	07/02/2025	Rubber seal P/N 13051388 added
1.3	20/06/2025	RDM control panel screen changed

June 20, 2025

Specifications are subject to change without notice.

Copyright © 2023 -2025 Robe Lighting - All rights reserved

Made in CZECH REPUBLIC by ROBE LIGHTING s.r.o. Palackeho 416/20 CZ 75701 Valasske Mezirici

**DMX protocol for: Eminere 1/2/3/4; Eminere Side 1/2/3/4;  
Eminere Inground 2/4; Eminere Remote 1/2/3/4;  
UVinere 2/4; UVinere Remote 1/2/4**

Version: 3.3 (23 modes in total), software version 3.0 and higher

Mode/Channels in all								Mode 1: RGBW(A)-8bit, Mode 2: RGB 8-bit, Mode 3: full RGBW(A)	
1	2	3	4	5	6	7	8-10	Mode 4: White-full control, Mode 5: Reduced RGBW(A)	
4	3	12	3	6	8	15	Reserved	Mode 6- Reduced RGBW(A)+white control	
								Mode 7- full RGBW(A)+virtual colour wheel	
								RGBW(A) / RGB modes	
Mode/channels							DMX Value	Function	Type of control
1	2	3	4	5	6	7			
-	-	-	-	-	-	1	0	<b>Special functions</b> No function	step
								<i>To activate following functions , stop in DMX value for at least 3 sec.</i>	
							1-2	Save current DMX values to fixture as initial DMX values.	step
							3-4	Show saved initial DMX values	step
							5-6	Run factory demo sequences at switching fixture on (without DMX)	step
							7-8	Insect friendly light On (RGBA version only)	step
							9-10	Insect friendly light Off (RGBA version only)	step
							11-255	Reserved	
1	1	1	-	1	1	2	0-255	<b>Red</b> Red LEDs saturation control (0-100%)	proportional
-	-	2	-	-	-	3	0-255	<b>Red Fine</b> Red LEDs saturation control fine	proportional
2	2	3	-	2	2	4	0-255	<b>Green</b> Green LEDs saturation control (0-100%)	proportional
-	-	4	-	-	-	5	0-255	<b>Green Fine</b> Green LEDs saturation control fine	proportional
3	3	5	-	3	3	6	0-255	<b>Blue</b> Blue LEDs saturation control (0-100%)	proportional
-	-	6	-	-	-	7	0-255	<b>Blue Fine</b> Blue LEDs saturation control fine	proportional
4	-	7	-	4	4	8	0-255	<b>White (Amber)</b> White LEDs saturation control (0-100%)	proportional
-	-	8	-	-	-	9	0-255	<b>White (Amber) Fine</b> White LEDs saturation control fine	proportional
-	-	9	1	-	5	10	0	<b>Green correction</b> Uncorrected white	step
							1-127	Minus green --> uncorrected white	proportional
							128	Uncorrected white (128=default)	step
							129-255	Uncorrected white --> Plus green	proportional
-	-	10	2	-	6	11	0	<b>Colour temperature correction (CTC)</b> No function	step
							1-10	Tungsten dimming 2700 K	step
							11-20	Tungsten dimming 3200 K	step
							21-255	Colour temperature changing from 1800 K --> 6500 K	proportional

DMX protocol

Mode/channels							DMX Value	Function	Type of control
1	2	3	4	5	6	7			
								(21-1800K, 66-2700K, 91-3200K,141-4200K, 211-5600K, 255-6500K)	
-	-	-	-	-	-	12		<b>Virtual Colour Wheel</b>	
							0	No function	step
							1-2	White 1800 K	step
							3-4	White 2700 K	step
							5-6	White 3200 K	step
							7-8	White 4200 K	step
							9-10	White 5600 K	step
							11-12	White 6500 K	step
							13	Blue (Blue=full, Red+Green+White/Amber=0)	step
							14-23	Red=0, Green->up,Blue =full, White/Amber=0	proportional
							24	Cyan (Red=0, Green=full, Blue =full, White/Amber=0)	step
							25-34	Red=0, Green=full, Blue->down, White/Amber=0	proportional
							35	Green (Red=0, Green=full, Blue =0, White/Amber=0)	step
							36-45	Red->up, Green=full, Blue=0, White/Amber=0	proportional
							46	Yellow (Red=full, Green=full, Blue=0, White/Amber=0)	step
							47-56	Red=full, Green->down, Blue=0, White/Amber=0	proportional
							57	Red(Red=full, Green=0, Blue=0, White/Amber=0)	step
							58-67	Red=full, Green=0, Blue->up, White/Amber=0	proportional
							68	Magenta (Red=full, Green=0, Blue=full, White/Amber=0)	step
							69-78	Red -> down, Green=0, Blue=full, White/Amber=0	proportional
							79	Blue (Red=0, Green=0, Blue=full, White/Amber=0)	step
								<b>Transition effects</b>	
							80-87	Rainbow effect (with fade time) from slow-> fast	proportional
							88-95	Rainbow effect (without fade time) from slow-> fast	proportional
							96-103	Full dynamic white (1800K->6500K->1800K) (with fade time) from slow-> fast	proportional
							104-111	Full dynamic white (1800K->6500K->1800K) (without fade time) from slow-> fast	proportional
							112-119	Dynamic warm white (1800K-3000K-1800K) (with fade time) from slow-> fast	proportional
							120-127	Dynamic warm white (1800K-3000K-1800K) (without fade time) from slow-> fast	proportional
							128-135	Rainbow effect + full dynamic white (with fade time) from slow-> fast	proportional
							136-143	Rainbow effect + full dynamic white (without fade time) from slow-> fast	proportional
							144-151	Blue/Green effect (with fade time) from slow-> fast	proportional
							152-159	Blue/Green effect (without fade time) from slow-> fast	proportional
							160-167	Red/Blue effect (with fade time) from slow-> fast	proportional
							168-175	Red/Blue effect (without fade time) from slow-> fast	proportional
							176-183	Green/Red effect (with fade time) from slow-> fast	proportional
							184-191	Green/Red effect (without fade time) from slow-> fast	proportional
							192-199	Blue/4000K effect (with fade time) from slow-> fast	proportional
							200-207	Blue/4000K effect (without fade time) from slow-> fast	proportional
							208-215	Green/4000K effect (with fade time) from slow-> fast	proportional
							216-223	Green/4000K effect (without fade time) from slow-> fast	proportional
							224-231	Red/4000K effect (with fade time) from slow-> fast	proportional
							232-239	Red/4000K effect (without fade time) from slow-> fast	proportional
							240-255	Reserved	

DMX protocol

Mode/channels							DMX Value	Function	Type of control
1	2	3	4	5	6	7			
						13		<b>Shutter/Strobe</b>	
							0-31	Shutter closed	step
							32-63	Shutter open	step
							64-95	Strobe-effect from slow to fast	proportional
							96-127	Shutter open	step
							128-143	Opening pulse in sequences from slow to fast	proportional
							144-159	Closing pulse in sequences from fast to slow	proportional
							160-191	Shutter open	step
							192-223	Random strobe-effect from slow to fast	proportional
							224-255	Shutter open	step
-	-	11	3	5	7	14		<b>Dimmer</b>	
							0-255	Light intensity coarse (0-100%)	proportional
-	-	12	-	6	8	15		<b>Dimmer Fine</b>	
							0-255	Light intensity fine	proportional
Copyright © 2022-2024 Robe Lighting s.r.o. - All rights reserved									
All Specifications subject to change without notice									

DMX protocol for: Eminere 1/2/3/4; Eminere Side 1/2/3/4; Eminere Inground 2/4; Eminere Remote 1/2/3/4; UVinere 2/4; UVinere Remote 1/2/4					
Version: 3.3 (23 modes in total)					
<b>Mode/Channels in all</b>				Mode 11: White selection, Mode 12: WW + CW	
<b>11</b>	<b>12</b>	<b>13</b>	<b>14-16</b>	Mode 13: Only dimmer	
3	4	2	Reserved	<i>Mode 13 is suitable for UVinere and UVinere Remote</i>	
<b>TW and PW modes</b>					
Mode/channels			DMX Value	Function	Type of control
11	12	13			
1	-	-	0 - 255	<b>White colour selection</b> White from 2700 K - 6500 K	proportional
-	1	-	0 - 255	<b>Warm White</b> Warm White LEDs saturation control (0-100%)	proportional
-	2	-	0 - 255	<b>Cool White</b> Cool White LEDs saturation control (0-100%)	proportional
2	3	1	0 - 255	<b>Dimmer</b> Light intensity coarse (0 - 100%)	proportional
3	4	2	0 - 255	<b>Dimmer Fine</b> Light intensity fine	proportional
Copyright © 2022-2024 Robe Lighting s.r.o. - All rights reserved					
All Specifications subject to change without notice					

**DMX protocol for: Eminere 1/2/3/4; Eminere Side 1/2/3/4;  
Eminere Inground 2/4; Eminere Remote 1/2/3/4;**

Version: 3.3 (23 modes in total)

Mode/Channels in all					Mode 17: RGBW(A) pixels, Mode 18: RGB pixels, Mode 19: TW pixels, Mode 20: PW dimmer pixels		
17	18	19	20	21-23			
16	12	8	8	Reserved			
Mode/channels					DMX Value	Function	Type of control
17	18	19	20				
1	1	-	-	0 - 255	<b>Red 1 -Eminere 1/2/3/4</b> Red LEDs saturation control (0-100%)	proportional	
2	2	-	-	0 - 255	<b>Green 1-Eminere 1/2/3/4</b> Green LEDs saturation control (0-100%)	proportional	
3	3	-	-	0 - 255	<b>Blue 1-Eminere 1/2/3/4</b> Blue LEDs saturation control (0-100%)	proportional	
4	-	-	-	0 - 255	<b>White (Amber) 1-Eminere 1/2/3/4</b> White LEDs saturation control (0-100%)	proportional	
5	4	-	-	0 - 255	<b>Red 2 -Eminere 2/3/4</b> Red LEDs saturation control (0-100%)	proportional	
6	5	-	-	0 - 255	<b>Green 2-Eminere 2/3/4</b> Green LEDs saturation control (0-100%)	proportional	
7	6	-	-	0 - 255	<b>Blue 2-Eminere 2/3/4</b> Red LEDs saturation control (0-100%)	proportional	
8	-	-	-	0 - 255	<b>White (Amber) 2-Eminere 2/3/4</b> White LEDs saturation control (0-100%)	proportional	
9	7	-	-	0 - 255	<b>Red 3-Eminere 3/4</b> Red LEDs saturation control (0-100%)	proportional	
10	8	-	-	0 - 255	<b>Green 3-Eminere 3/4</b> Green LEDs saturation control (0-100%)	proportional	
11	9	-	-	0 - 255	<b>Blue 3-Eminere 3/4</b> Blue LEDs saturation control (0-100%)	proportional	
12	-	-	-	0 - 255	<b>White (Amber) 3-Eminere 3/4</b> White LEDs saturation control (0-100%)	proportional	
13	10	-	-	0 - 255	<b>Red 4-Eminere 4</b> Red LEDs saturation control (0-100%)	proportional	
14	11	-	-	0 - 255	<b>Green 4-Eminere 4</b> Green LEDs saturation control (0-100%)	proportional	
15	12	-	-	0 - 255	<b>Blue 4-Eminere 4</b> Blue LEDs saturation control (0-100%)	proportional	
16	-	-	-	0 - 255	<b>White (Amber) 4 -Eminere 4</b> White LEDs saturation control (0-100%)	proportional	
-	-	1	-		<b>Warm White 1 -Eminere 1/2/3/4</b> Warm White LEDs saturation control (0-100%)	proportional	
-	-	2	-	0 - 255	<b>Cool White 1-Eminere 1/2/3/4</b> Cool White LEDs saturation control (0-100%)	proportional	
-	-	3	-		<b>Warm White 2-Eminere 2/3/4</b>		

DMX protocol

Mode/channels				DMX Value	Function	Type of control
17	18	19	20			
				0 - 255	Warm White LEDs saturation control (0-100%)	proportional
-	-	4	-	0 - 255	<b>Cool White 2-Eminere 2/3/4</b> Cool White LEDs saturation control (0-100%)	proportional
-	-	5	-	0 - 255	<b>Warm White 3-Eminere 3/4</b> Warm White LEDs saturation control (0-100%)	proportional
-	-	6	-	0 - 255	<b>Cool White 3-Eminere 3/4</b> Cool White LEDs saturation control (0-100%)	proportional
-	-	7	-	0 - 255	<b>Warm White 4 -Eminere 4</b> Warm White LEDs saturation control (0-100%)	proportional
-	-	8	-	0 - 255	<b>Cool White 4 -Eminere 4</b> Cool White LEDs saturation control (0-100%)	proportional
-	-	-	1	0 - 255	<b>Dimmer 1</b> Light intensity coarse (0 - 100%)	proportional
-	-	-	2	0 - 255	<b>Dimmer Fine 1</b> Light intensity fine	proportional
-	-	-	3	0 - 255	<b>Dimmer 2</b> Light intensity coarse (0 - 100%)	proportional
-	-	-	4	0 - 255	<b>Dimmer Fine 2</b> Light intensity fine	proportional
-	-	-	5	0 - 255	<b>Dimmer 3</b> Light intensity coarse (0 - 100%)	proportional
-	-	-	6	0 - 255	<b>Dimmer Fine 3</b> Light intensity fine	proportional
-	-	-	7	0 - 255	<b>Dimmer 4</b> Light intensity coarse (0 - 100%)	proportional
-	-	-	8	0 - 255	<b>Dimmer Fine 4</b> Light intensity fine	proportional
Copyright © 2022-2024 Robe Lighting s.r.o. - All rights reserved						
All Specifications subject to change without notice						