

CALUMMA™ XL MC

Featuring an optical design using nineteen high efficacy multichip LEDs and available with optional LED colour variants and various beam angles, the extra large-sized Calumma XL MC luminaire creates powerful and beautiful light output for a spot, accent or flood lighting solution. Its durable housing is built to withstand any exterior conditions, and its special finish for harsh and marine environments provides an exceptional outdoor LED luminaire in an elegant design. Additionally, Calumma XL MC can be connected in long In/Out daisy-chains via an E-Box and hybrid Plug & Play connections for almost effortless installation. Complemented by wide range of accessories and control protocols, this luminaire is an effective and versatile unit to get the most out of architectural lighting applications.



KEY FEATURES

Lumen output & Light source

Luminaire with nineteen high-power, multi-chip LEDs provides up to 6286 lumen output. Multiple LED colour variants. No light spills. Perfectly homogenised light output with efficacy up to 36 lm/w.

Design & Durability

Compact, durable and stylish housing made of high-pressure die cast aluminium. IP67 and IK10 certification; suitable for marine applications (Harsh Environment Finish required) and traffic applications. Supported with a 5 year warranty.

Flexibility

Exceptional outdoor or indoor LED luminaire with a wide range of accessories, custom colour finishes, multiple light output variants and beam angles.

Connectivity

Utilising the innovative E-Box series of power and data interfaces, Calumma XL MC can communicate via numerous wired, wireless, and Ethernet based control protocols. Various wiring topologies are supported using hybrid power / data cables with Plug & Play connectors or standard connection options.

COLOURS

* UPON REQUEST



COLOUR TEMPERATURE

* UPON REQUEST

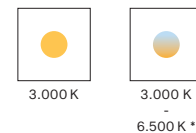

CONTROL & PROTOCOLS



OPTIC OPTIONS

SYMMETRICAL

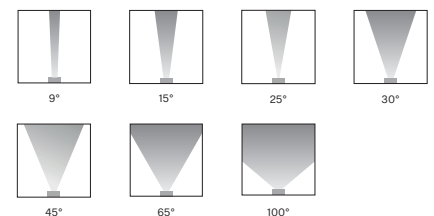

BI-SYMMETRICAL

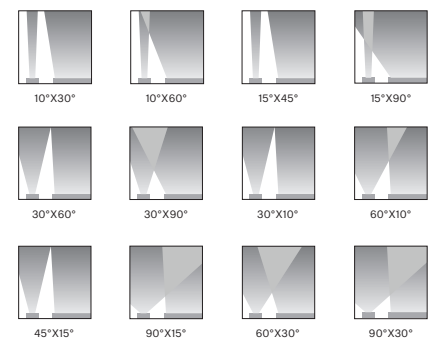

STANDARD & SPECIFICATION

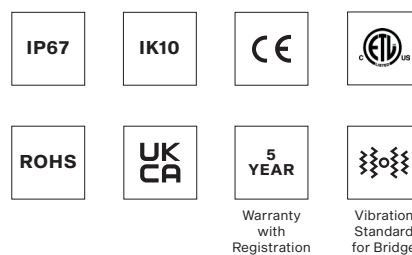

FINISH OPTIONS

* CLOSEST RAL TONE

* HE = Harsh Environment



SPECIFICATION

ELECTRICAL	Input Voltage	120 - 277 V AC 50/60 Hz (US)		
	Typical Power Consumption	175 W +/- 10 %		
OPTICAL	Light Source	High Power Multichip LEDs		
	Colour Variants	RGBW (W - 6500 K) RGBA PW (W - 3000 K)		
		Other Variants On Request (TW 3000 - 6500 K)		
	Beam Angle	9° 15° 25° 30° 45° 65° 100°		
		10°x30° 30°x10° 10°x60° 60°x10° 15°x45° 45°x15° 15°x90° 90°x15° 30°x60° 60°x30° 30°x90° 90°x30°		
Lumen Output Delivered	6286 lm (@9° RGBW)			
Projected Lumen Maintenance	L90B10 >90.000 hrs, Ta = 25°C / 77°F			
CONTROL	Interface Protocol	Via E-box range, DMX/RDM, wireless DMX, DALI 2		
	E-box control protocol	USITT DMX512+RDM, ArtNet, MA Net, MA Net2, sACN, Kling-Net		
	DALI 2 Device Type	DT 8		
	Wireless DMX (Option)	Lumen Radio CRMX Technology		
	Control System	Third Party DMX Controllers		
	Operating Modes	DMX, Stand-alone		
	Settings / Addressing	E-box, RDM communicator		
	Power Supply	Integrated		
PHYSICAL	Width x Height x Depth Weight	385 x 404 x 120 mm (15.16 x 15.91 x 4.72 in.) 12.3 kg (27.12 lbs)		
	Housing	High Pressure Die-Cast Aluminium Body Tempered Glass		
	Finish Options	Standard Colour	Graphite Black RAL 9011 Grey Aluminium RAL 9007 Pure White RAL 9010 Sandstone RAL 1014	
		Standard Colour Harsh Environment	Graphite Black RAL 9011 Grey Aluminium RAL 9007 Pure White RAL 9010 Sandstone RAL 1014	
		Cost Option	Custom RAL	
	Cables / Connections	IN/OUT (for E- Box version): - 0,5 m cables with hybrid connectors - Jumper cables	IN (for DMX, DALI): - 1 m cable with bare end - Other cable length - custom - Junction box - optional	
	Mounting Method	Yoke or Yoke for Pole Adaptor		
Adjustability	+180° / -180°			
Protection Factor	IP67 / Suitable For Wet Locations			
IK Rating	IK10			
Cooling System	Convection			
Operating Ambient Temperature	-20 °C / +50 °C (-4 °F / +122 °F)			
CERTIFICATION	Listings	ETL / cETL, CE, RoHS, UKCA		
ACCESSORIES	Not Included Items			
	Junction Box (CE or US)			
	Re-enterable Electrical Insulating Resin			
	Optical Demo Set for Calumma XL (for demo purposes)			
	Outdoor Foil Holder for Calumma XL „OFH“ version only (for permanent installation)			
	Optical Foil Set for Outdoor Foil Holder Calumma XL			
	Land Spike for Calumma XL			
	Top Hat Calumma XL			
	Half Top Hat Calumma XL			
	Tenon Adaptor			
	Floor stand for Calumma L, XL			
Pole Adaptor (ø 102mm) (Yoke for Pole Adaptor Required)				

CONTROL AND CONNECTION OPTIONS - CE

DALI

- 1) Hybrid Cable (1305 3693)
Standard 1 m with bare-end
- 2) Hybrid Cable (1305 3693)
or Scope of Others
- 3) Junction Box

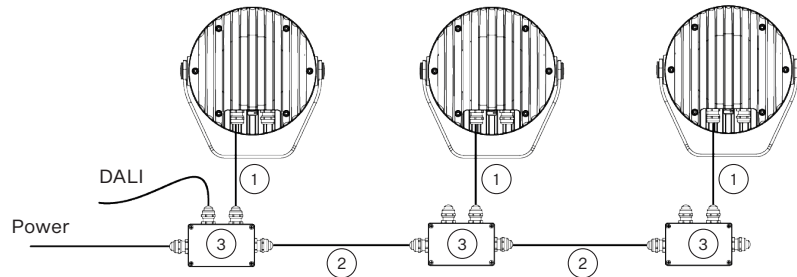

DMX

- 1) Flamar 3x AWG 16 + 1x (2x AWG 24)
Standard 1 m with bare-end, (13051508), black
or
Hybrid Cable HYB-5731ZH LSZH (13053694), white
- 2) Flamar 3x AWG 16 + 1x (2x AWG 24), (13051508), black
or
Hybrid Cable HYB-5731ZH LSZH (13053694) white
or
Scope of Others
- 3) Junction Box

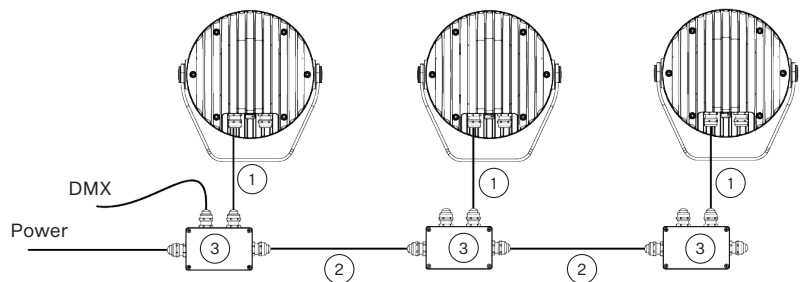

WIRELESS DMX

- 1) Flamar 3x AWG 16 + 1x (2x AWG 24),
(13051508), Standard 1 m bare-end, black
or
Hybrid Cable HYB-5731ZH LSZH (13053694), white
- 2) Junction Box

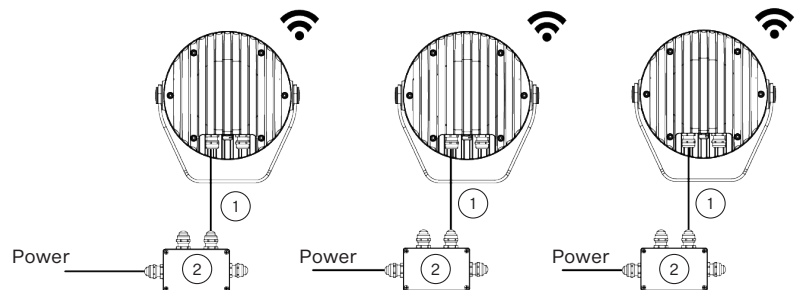

Note: This type of connection is available for M, L, XL versions.

- 1) Flamar 3x AWG 16 + 1x (2x AWG 24)
(13051508), Standard 1 m bare-end, black
or
Hybrid Cable HYB-5731ZH LSZH (13053694), white
- 2) Junction Box
- 3) Flamar 3x AWG 16 + 1x (2x AWG 24), (13051508)
or
Hybrid Cable HYB-5731ZH LSZH (13053694), white
or
Scope of Others

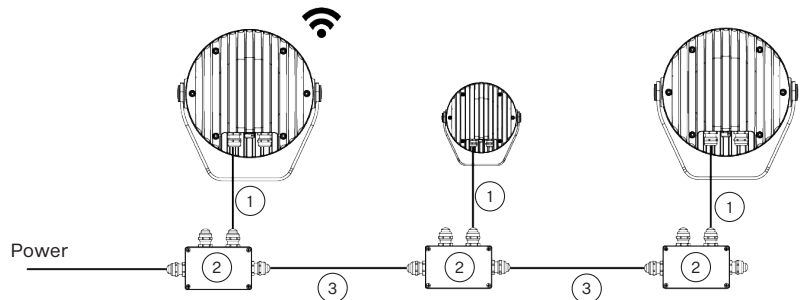

Note: This type of connection must have M, L or XL versions as the first luminaire. Next luminaires in a row could be chosen from S, M, L or XL versions.

CONTROL AND CONNECTION OPTIONS - CE

DMX or ETHERNET via E-BOX

- 1) Flamar 3x AWG 16 + 1x (2x AWG 24) (13051508), Standard 1 m with bare-end, black or Hybrid Cable HYB-5731ZH LSZH (13053694), white
- 2) Junction Box
- 3) Flamar 3x AWG 16 + 1x (2x AWG 24), (13051508), black or Hybrid Cable HYB-5731ZH LSZH (13053694) white or Scope of Others

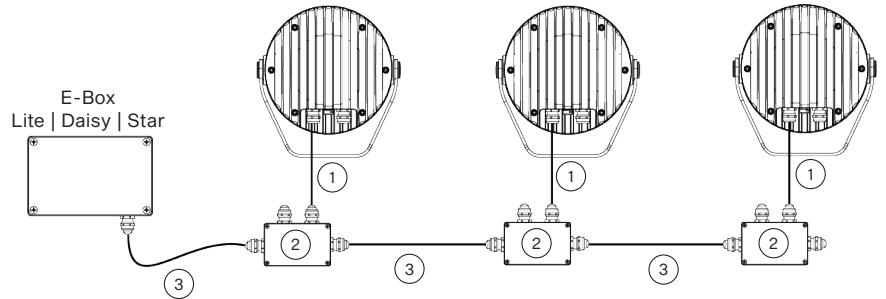

Note: This type of connection is available for S, M, L, and XL versions. E-Box has to be in Pass Through mode only.

- 1) Leader Cable MM (13053493) Standard 0,5 m with hybrid connector
- 2) Leader Cable MF (13053494) Standard 0,5 m with hybrid connector
- 3) Leader Cable FF 2 m (13053438)
Leader Cable FF 5 m (13053440)
Leader Cable FF 10 m (13053436)
Leader Cable FF 25 m (13053437)
Leader Cable FF 50 m (13053439)

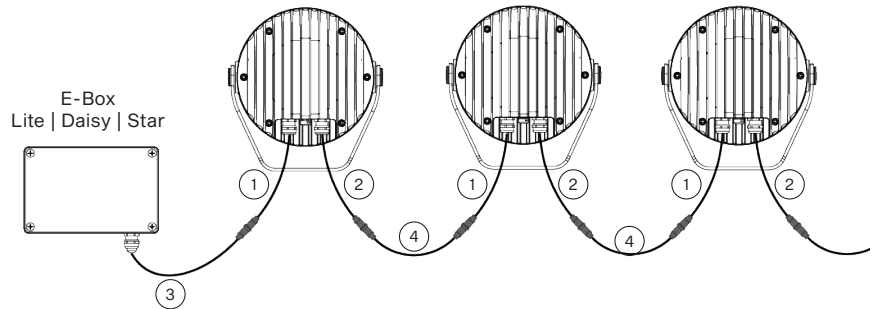

- 4) Jumper Cable FF/FM 0,25 m (13053422)
Jumper Cable FF/FM 0,5 m (13053423)
Jumper Cable FF/FM 1 m (13053425)
Jumper Cable FF/FM 2 m (13053427)
Jumper Cable FF/FM 3 m (13053428)
Jumper Cable FF/FM 5 m (13053430)
Jumper Cable FF/FM 10 m (13053424)

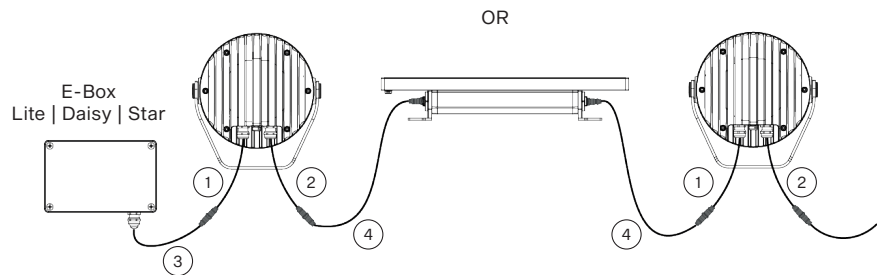

Note: With this type of connection is possible to connect Calumma (M, L, XL) and Eminere (Eminere, Eminere Side) luminaires in a row.

CONTROL AND CONNECTION OPTIONS - US

DALI

- 1) SJTW 5x 14AWG (13053336), Standard 1 m with bare-end, black
or
Cable SJTW 5x 14AWG (13053697), white
- 2) SJTW 5x 14AWG (13053336), black
or
Cable SJTW 5x 14AWG (13053697), white
or
Scope of Others
- 3) Junction Box

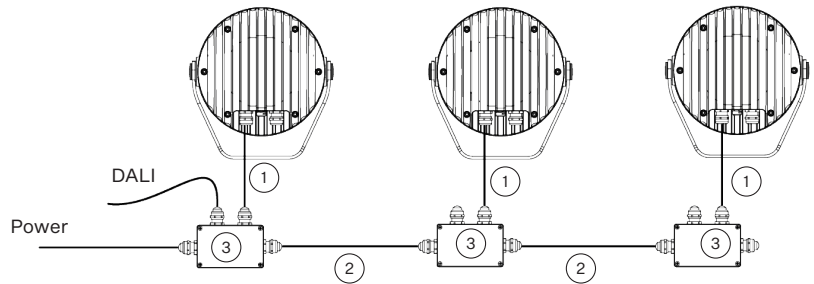

WIRELESS DMX

- 1) SJTW 6x 14AWG (13053480), Standard 1 m with bare-end, black
or
Cable SJTW 6x 14AWG (13053695), white
- 2) Junction Box

Note: This type of connection is available for M, L, XL versions

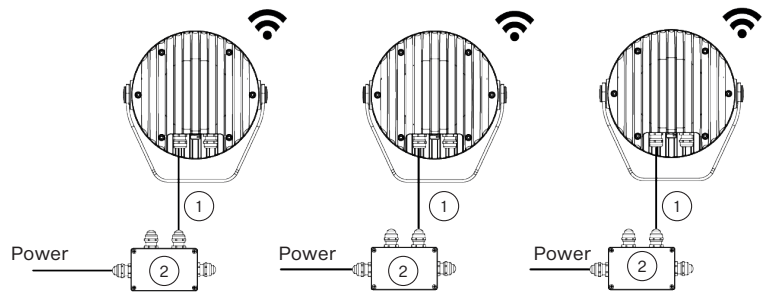

- 1) SJTW 6x 14AWG (13053480), Standard 1 m with bare-end, black
or
Cable SJTW 6x 14AWG (13053695), white
- 2) Junction Box
- 3) SJTW 6x 14AWG (13053480), black
or
Cable SJTW 6x 14AWG (13053695), white
or
Scope of Others

Note: This type of connection must have M, L or XL versions as the first luminaire. Next luminaires in a row could be chosen from S, M, L or XL versions.

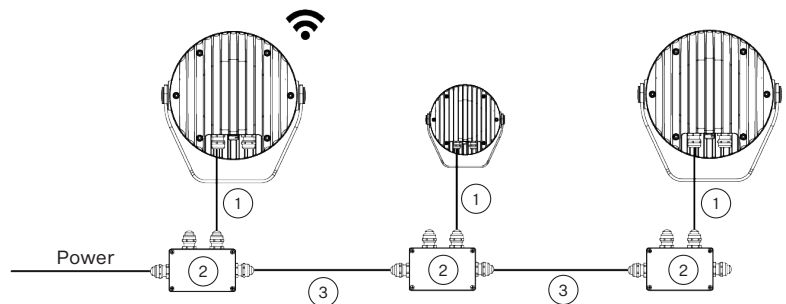

CONTROL AND CONNECTION OPTIONS - US

DMX or ETHERNET via E-BOX

- 1) SJTW 6x 14AWG (13053480)
Standard 1 m with bare-end, black
or
Cable SJTW 6x 14AWG (13053695), white
- 2) Junction Box
- 3) SJTW 6x 14AWG (13053480), black
or
Cable SJTW 6x 14AWG (13053695), white
or
Scope of Others

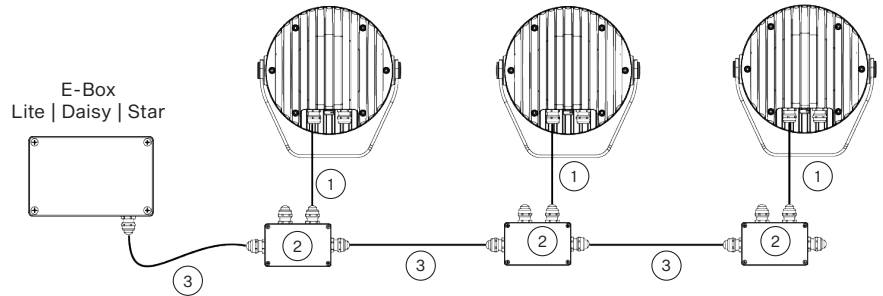

Note: This type of connection is available for S, M, L, and XL versions. E-Box has to be in Pass Through mode only.

CONNECTIVITY

Following table shows maximum connected Calummas XL MC in a row with respect of cable length.

STANDARD MODE	Cable length (m)	Voltage (V)			
		120	190	230	277
CALUMMA XL MC	10	10	17	20	24
	20	10	17	20	24
	30	7	17	20	24
	50	4	11	16	23
	70	3	8	12	17
	100	2	6	8	12
	200	1	3	4	6
	500	0	1	2	2

PASS-THROUGH MODE	Cable length (m)	Voltage (V)			
		120	190	230	277
CALUMMA XL MC	10	10	17	20	24
	20	10	17	20	24
	30	7	17	20	24
	50	4	11	16	23
	70	3	8	12	17
	100	2	6	8	12

BOOSTER BOX POSITIONS

Cable length (m)	Max. number of Calummas XL MC= 191 (in Standard mode)			
	120 V	190 V	230 V	277 V
10 m	10, 20	17	20	24
20 m	10, 20, 30	17, 34	20, 40	24, 48
30 m	7, 14, 21, 28, 35, 42, 49, 56...	17, 34, 51, 68	20, 40, 60, 80	24, 48, 72
50 m	4, 8, 12, 16, 20, 24, 28, 32, 36, 40, 44, 48, 52, 56...	11, 22, 33, 44, 55, 66, 77, 88, 99, 110...	16, 32, 48, 64, 80, 96, 112	23, 46, 69, 92, 115
70 m	3, 6, 9, 12, 15, 18, 21, 24, 27, 30, 33, 36, 39, 42, 45, 48, 51, 54, 57, 60, 63, 66, 69, 72...	8, 16, 24, 32, 40, 48, 56, 64, 72, 80, 88...	12, 24, 36, 48, 56, 68, 80, 92, 104...	17, 34, 51, 68, 85, 102, 119...
100 m	2, 4, 6, 8, 10, 12, 14, 16, 18, 20...	6, 12, 18, 24, 30, 36...	8, 16, 24, 32, 40, 48, 56...	12, 24, 36, 48, 56, 68, 80...
200 m	1, 2, 3, 4, 5, 6, 7, 8, 9, 10, 11...	3, 6, 9, 12, 15, 18, 21, 24, 27, 30, 33, 36, 39, 42, 45, 48, 51, 54, 57, 60, 63, 66, 69, 72...	4, 8, 12, 16, 20, 24, 28, 32, 36, 40, 44, 48, 52, 56, 60, 64, 68, 72, 76, 80, 84...	6, 12, 18, 24, 30, 36, 42...
500 m	-	1, 2, 3, 4, 5, 6, 7, 8, 9, 10, 11...	2, 4, 6, 8, 10, 12, 14, 16, 18, 20...	2, 4, 6, 8, 10, 12, 14, 16, 18, 20...

NOTE: For more detail see the User manual.

PROJECTED AREA

	Front (rear) - m ²	Front (rear) ft ²	Side - m ²	Side - ft ²	Top - m ²	Top - ft ²
Calumma XL	0,105	1,130	0,044	0,469	0,042	0,446
with Top Hat	0,105	1,130	0,107	1,151	0,105	1,130
with Half Top Hat	0,105	1,130	0,064	0,684	0,105	1,130

DIMENSIONS

Standard Yoke

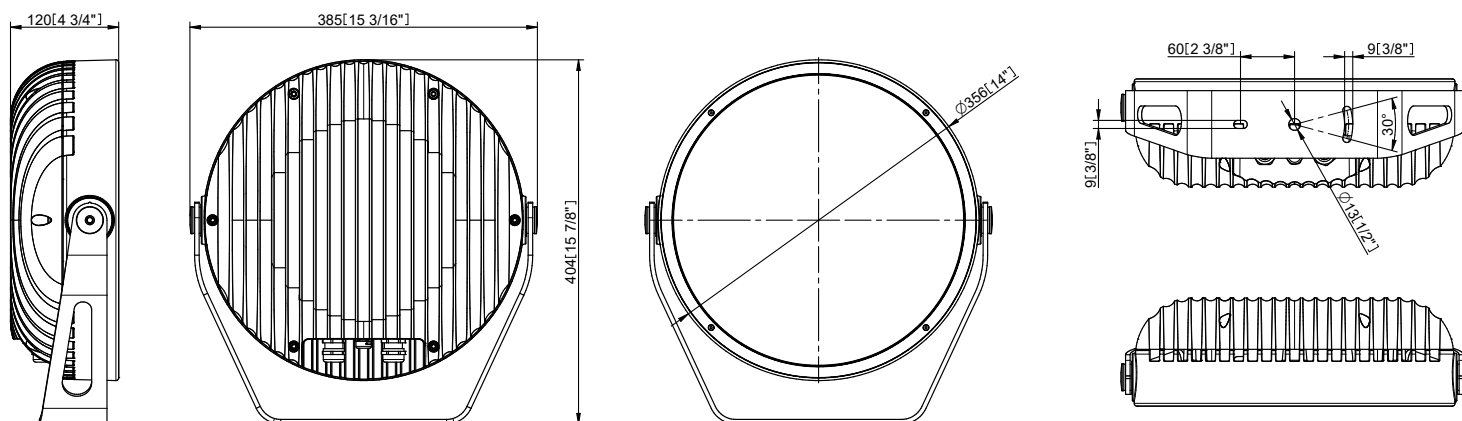

Yoke for Pole Adaptor (with Pole Adaptor / PA)

Example of ordering code: Calumma XL MC RGBCW 15° PA

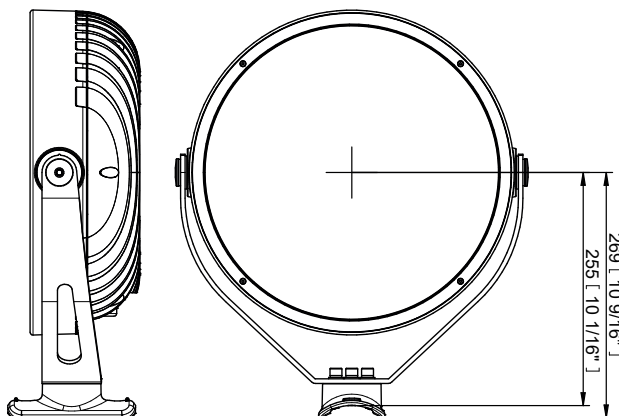

Outdoor Foil Holder for Calumma XL „OFH“ version only (for permanent installation)

Example of ordering code: Calumma XL MC CE RGBCW 9° RAL9007 OFH

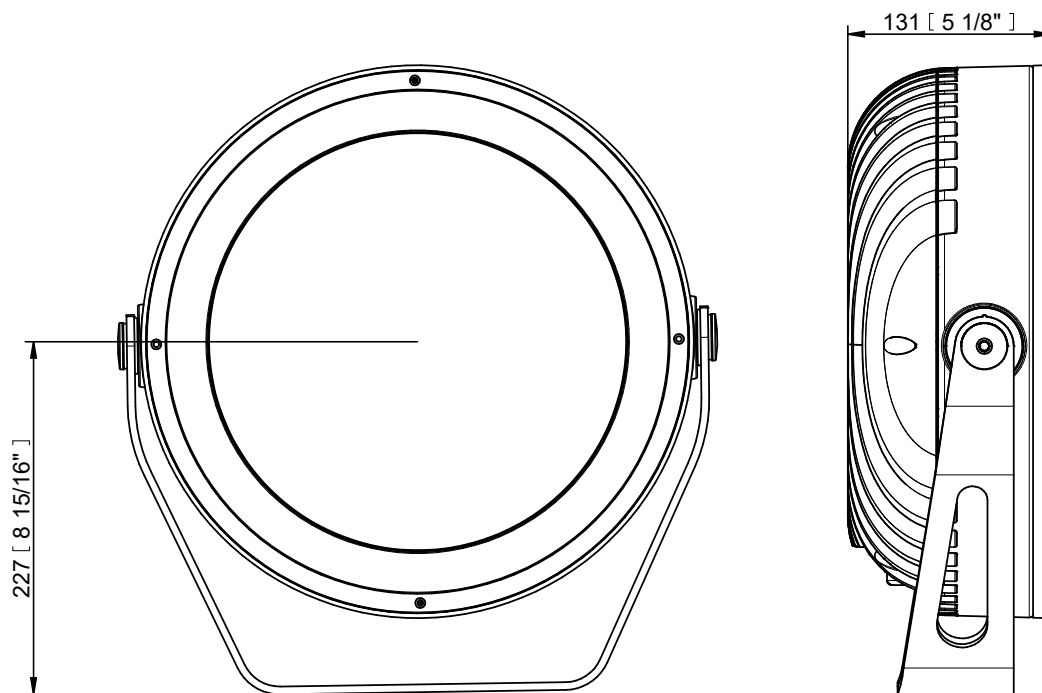

ACCESSORIES

Outdoor Foil Holder for Calumma XL

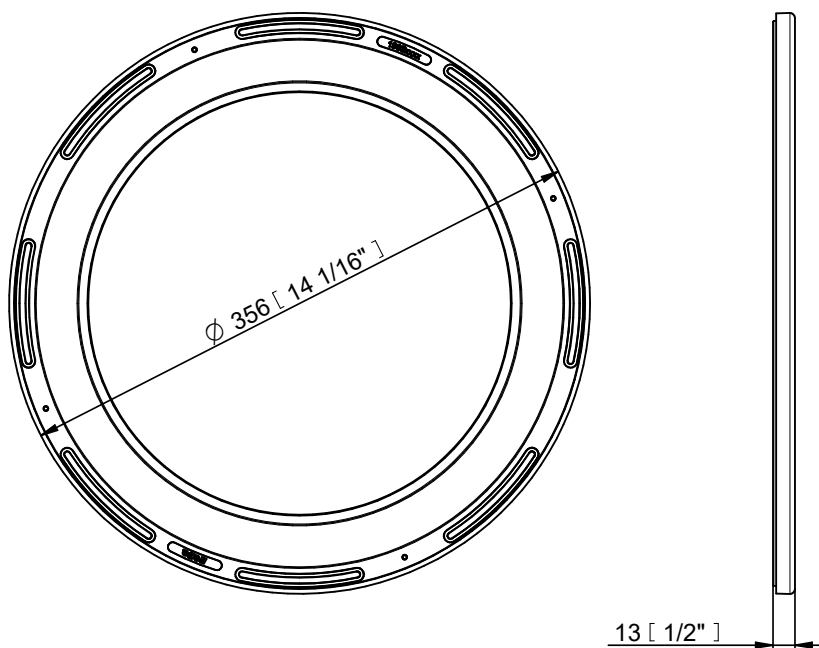

Top Hat

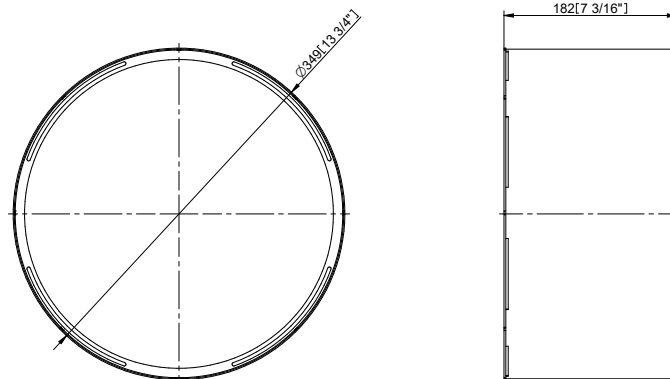

Half Top Hat

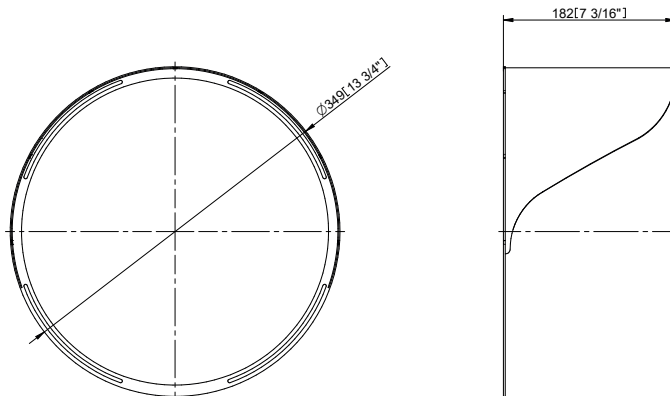

Floor Stand

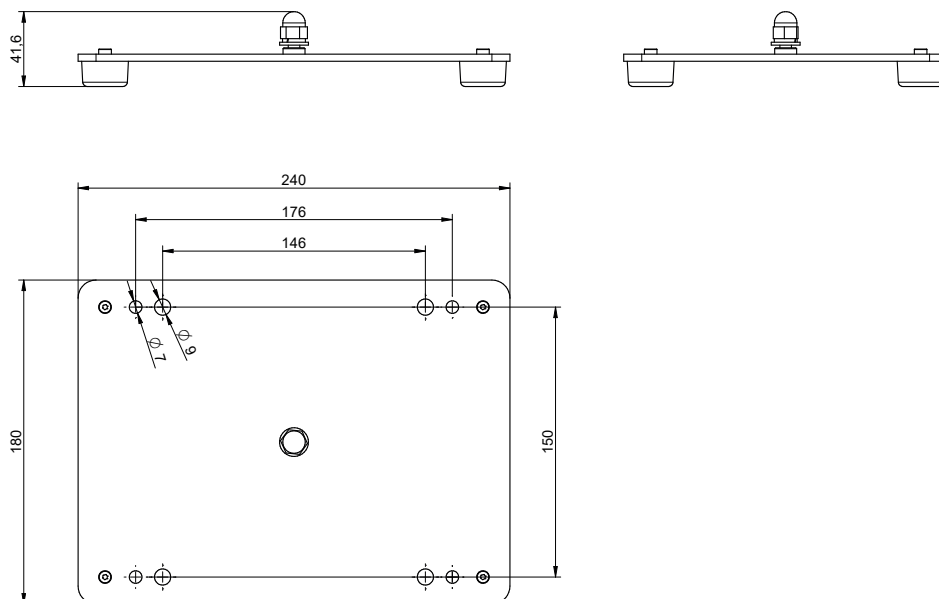

Pole Adaptor

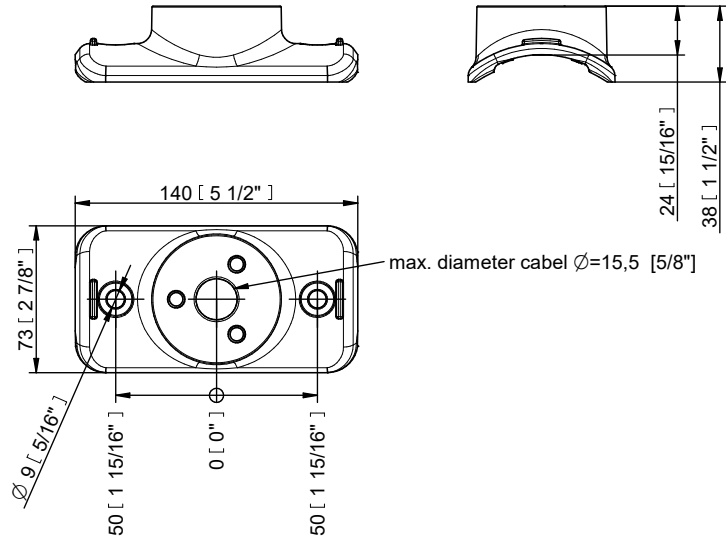

Land Spike for Calumma (S, M, L, XL)

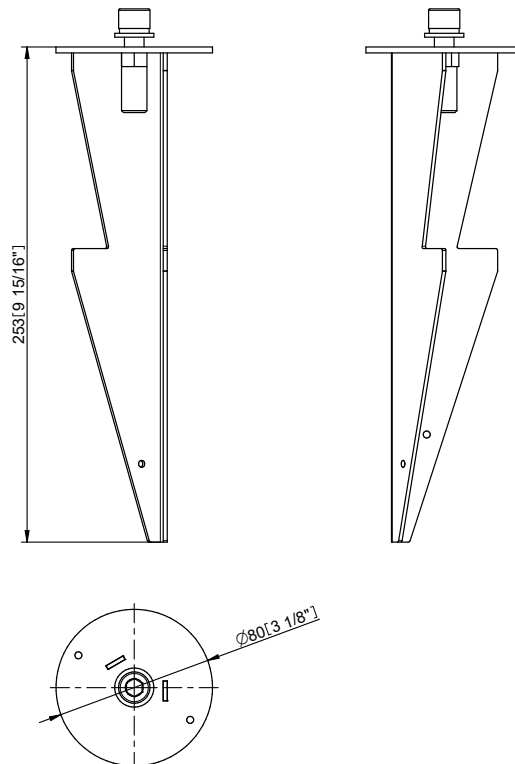

PHOTOMETRIC OVERVIEW

	Lumen Output (lm)		
	RGBCW (W 6500 K)	RGBA	WW (W 3000 K)
9°	6286	5390	5359
15°	4864	4171	4147
25°	4829	4141	4117
30°	4755	4078	4054
45°	4818	4132	4108
65°	4812	4134	4110
100°	4769	4090	4066
10° x 30°, 30° x 10°	4563	3913	3890
10° x 60°, 60° x 10°	5068	4346	4321
15° x 45°, 45° x 15°	5163	4427	4402
30° x 60°, 60° x 30°	4793	4110	4086
30° x 90°, 90° x 30°	5171	4434	4409
15° x 90°, 90° x 15°	5724	4909	4880

BI-SYMMETRICAL BEAM ANGLES

Bi-symmetrical:
10°x30°,
10°x60°,
15°x45°,
15°x90°,
30°x60°,
30°x90°

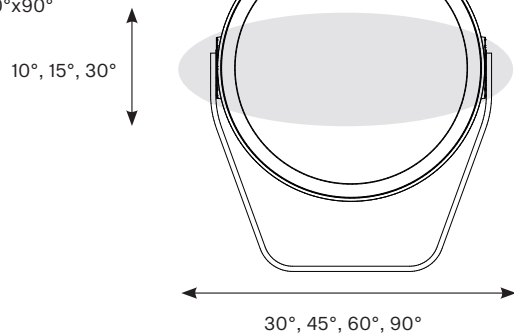

Bi-symmetrical:
30°x10°,
60°x10°,
45°x15°,
90°x15°,
60°x30°,
90°x30°

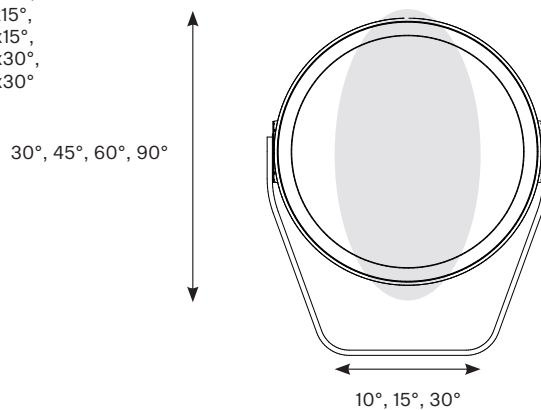

PHOTOMETRIC DATA

Calumma XL MC RGBW 6500K 10dg

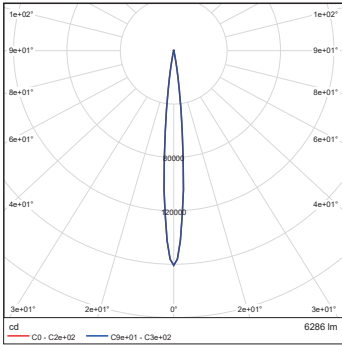

Calumma XL MC RGBW 6500K 15dg

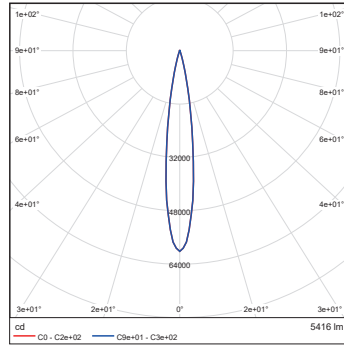

Calumma XL MC RGBW 6500K 25dg

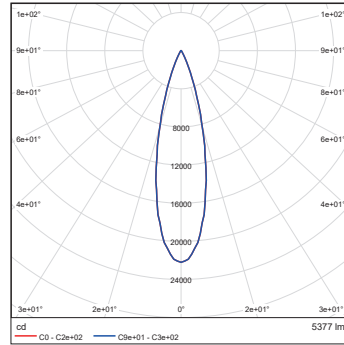

Calumma XL MC RGBW 6500K 30dg

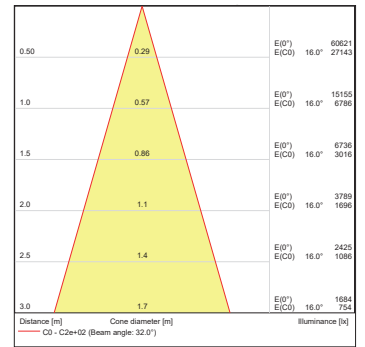
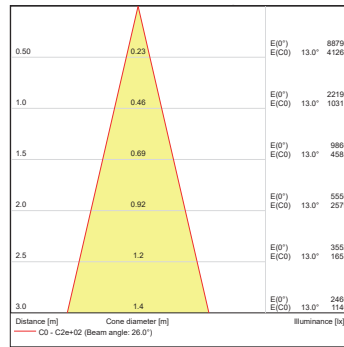
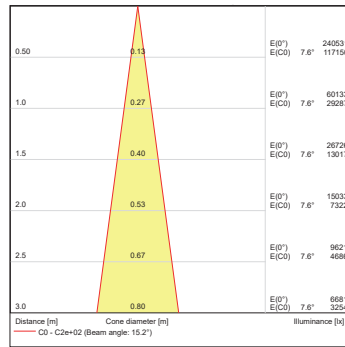
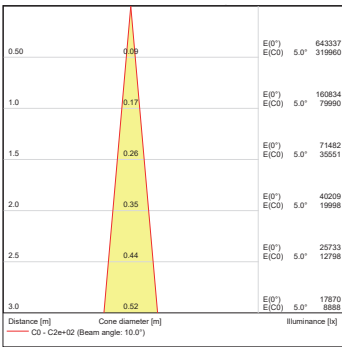
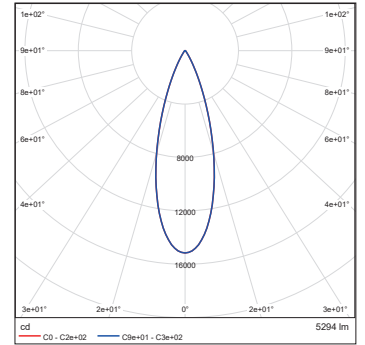

Calumma XL MC RGBW 6500K 45dg

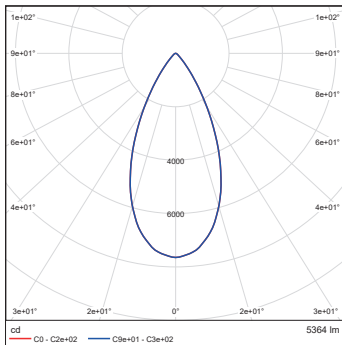

Calumma XL MC RGBW 6500K 65dg

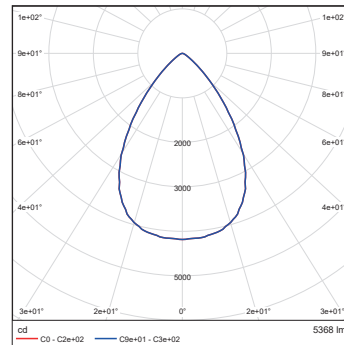

Calumma XL MC RGBW 6500K 100dg

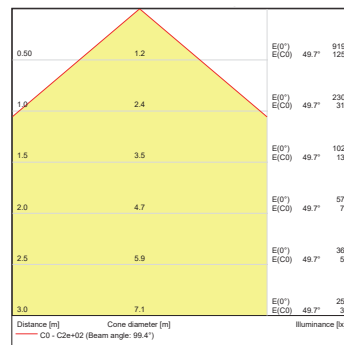
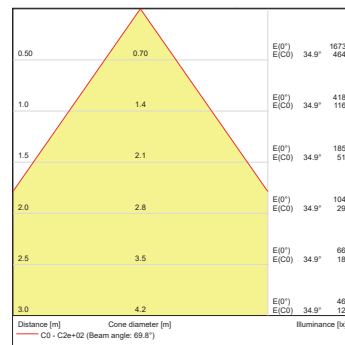
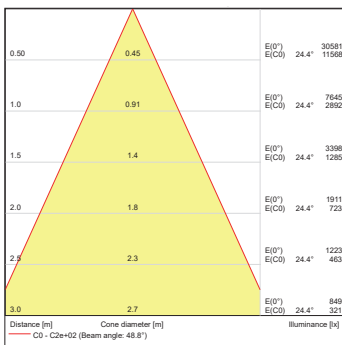
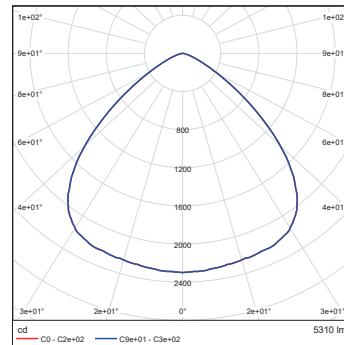

PHOTOMETRIC DATA

Calumma XL MC RGBW 6500K
10x30dg

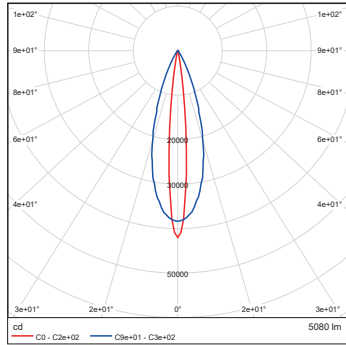

Calumma XL MC RGBW 6500K
10x60dg

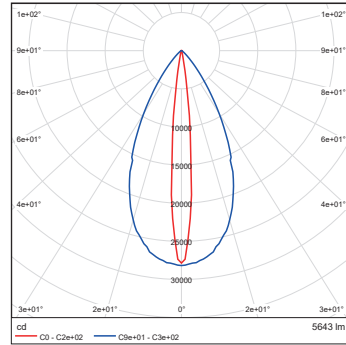

Calumma XL MC RGBW 6500K
15x45dg

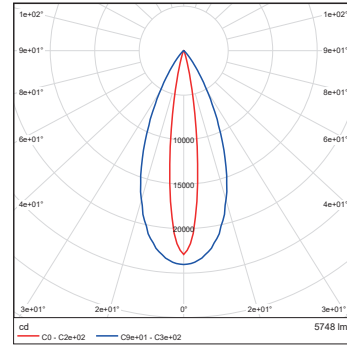

Calumma XL MC RGBW 6500K
15x90dg

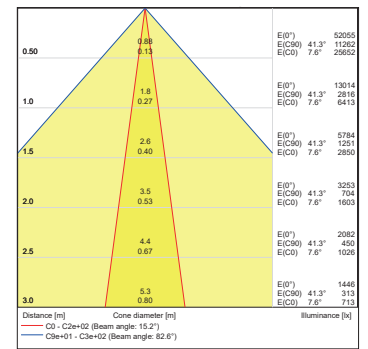
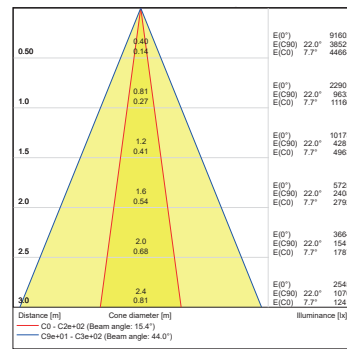
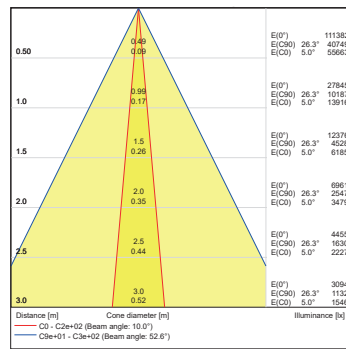
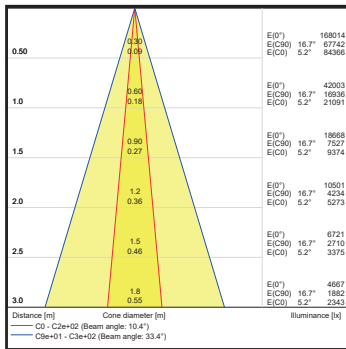
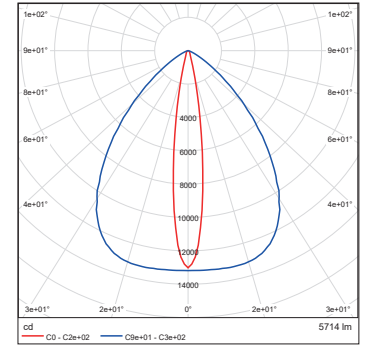

Calumma XL MC RGBW 6500K
30x60dg

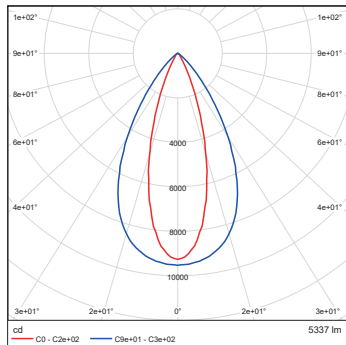

Calumma XL MC RGBW 6500K
30x90dg

