

CALUMMA™ REMOTE M SC

Featuring an optical design using high efficacy single-chip LEDs and available with optional LED colour variants and various beam angles, the medium-sized Calumma Remote M SC luminaire creates powerful and beautiful light output for a spot, accent or flood lighting solution. Its durable housing is built to withstand any exterior conditions, and its special finish for harsh and marine environments provides an exceptional outdoor LED luminaire in an elegant design. Complemented by wide range of accessories and control protocols via E-Box Remote, this luminaire is an effective and versatile unit to get the most out of architectural lighting applications.



KEY FEATURES

Lumen output & Light source

Luminaire with high-power, singlechip LEDs provides up to 3478 lumen output. Multiple LED colour variants. No light spills. Well homogenised light output with great efficacy up to 57 lm/w.

Design & Durability

Compact, durable and stylish housing made of high-pressure die cast aluminium. IP67 and IK10 certification; suitable for marine applications (Harsh Environment Finish required) and traffic applications. Supported with a 5 year warranty.

Flexibility

Exceptional outdoor or indoor LED luminaire with a wide range of accessories, custom colour finishes, multiple light output variants and beam angles.

Connectivity

Utilising the innovative E-Box Remote series of power and data interfaces, Calumma Remote M SC can communicate via numerous wired, wireless, and Ethernet based control protocols.

COLOURS



CONTROL & PROTOCOLS



OPTIC OPTIONS

SYMMETRICAL

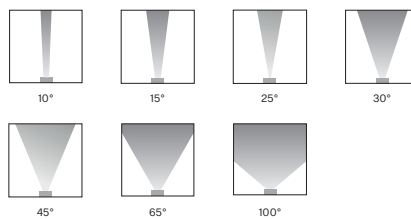

BI-SYMMETRICAL

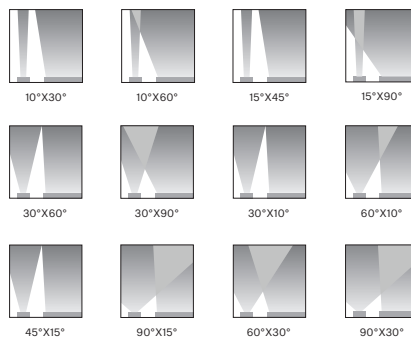

COLOUR TEMPERATURE

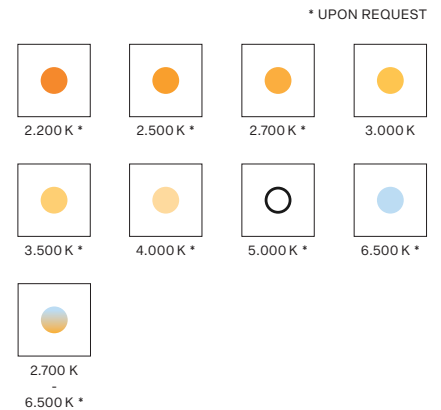

STANDARD & SPECIFICATION



FINISH OPTIONS

* CLOSEST RAL TONE
* HE = Harsh Environment



CALUMMA REMOTE M SC SPECIFICATION

ELECTRICAL	Input Voltage	48 V	
	Typical Power Consumption	60 W +/-10 %	
OPTICAL	Light Source	High Power Single Chip LEDs	
	Colour Variants	RGBW (W - 6500 K) RGBA PW (W - 3000 K) Other Variants On Request (TW (2700 - 6500 K), 2200 K, 2500 K, 2700 K, 3500 K, 4000 K, 5000 K, 6500 K)	
	Beam Angle	10° 15° 25° 30° 45° 65° 100° 10°x30° 30°x10° 10°x60° 60°x10° 15°x45° 45°x 15° 15°x90° 90°x15° 30°x60° 60°x30° 30°x90° 90°x30°	
	Lumen Output Delivered	3478 lm (@10° RGBW)	
	Projected Lumen Maintenance	L90B10 >90.000 hrs, Ta = 25°C / 77°F	
CONTROL	Interface Protocol	Via E-box Remote, E-box Remote Basic or E-Box Remote Basic Mini	
	E-box Remote control protocol	USITT DMX512+RDM, ArtNet, MA Net, MA Net2, sACN, Kling-Net	
	Settings / Addressing	Via Two Row LCD Display with Control Buttons on E-Box Remote or RDM communicator	
	Power Supply	Via E-Box Remote range	
PHYSICAL	Width x Height x Depth	264 x 278 x 106 mm (10.4 x 10.94 x 4.17 in.)	
	Weight	5.56 kg 12.3 lbs	
	Housing	High Pressure Die-Cast Aluminium Body Tempered Glass	
	Finish Options	Standard Colour	Graphite Black RAL 9011 Grey Aluminium RAL 9007 Pure White RAL 9010 Sandstone RAL 1014
		Standard Colour Harsh Environment	Graphite Black RAL 9011 Grey Aluminium RAL 9007 Pure White RAL 9010 Sandstone RAL 1014
		Cost Option	Custom RAL
	Cables / Connections	IN - Cable with bare end (Standard 1m, Longer upon Request) - Cable length - custom - Junction box - optional	
	Mounting Method	Yoke or Yoke for Pole Adaptor	
	Adjustability	+180° / -180°	
	Protection Factor	IP67 / Suitable For Wet Locations	
IK Rating	IK10		
Cooling System	Convection		
Operating Ambient Temperature	-20 °C / +50 °C (-4 °F / +122 °F)		
CERTIFICATION	Listings	ETL / cETL, CE, RoHS, UKCA	
ACCESSORIES	Not Included Items		
		Junction Box Remote (1x or 4x Output)	
		Optical Demo Set for Calumma M (for demo purposes)	
		Outdoor Foil Holder for Calumma M „OFH“ version only (for permanent installation)	
		Optical Foil Set for Outdoor Foil Holder Calumma M	
		Land Spike for Calumma M	
		Top Hat Calumma M	
		Half Top Hat Calumma M	
		Re-enterable Electrical Insulating Resin	
		Floor Stand for Calumma S, M	
		Tenon Adaptor Pole Adaptor (ø 102mm) (Yoke for Pole Adaptor Required)	

PROJECTED AREA

	Front (rear) - m ²	Front (rear) ft ²	Side - m ²	Side - ft ²	Top - m ²	Top - ft ²
Calumma Remote M	0,047	0,500	0,026	0,280	0,024	0,258
with Top Hat	0,047	0,500	0,054	0,581	0,052	0,559
with Half Top Hat	0,047	0,500	0,037	0,398	0,052	0,559

DIMENSIONS

Standard Yoke

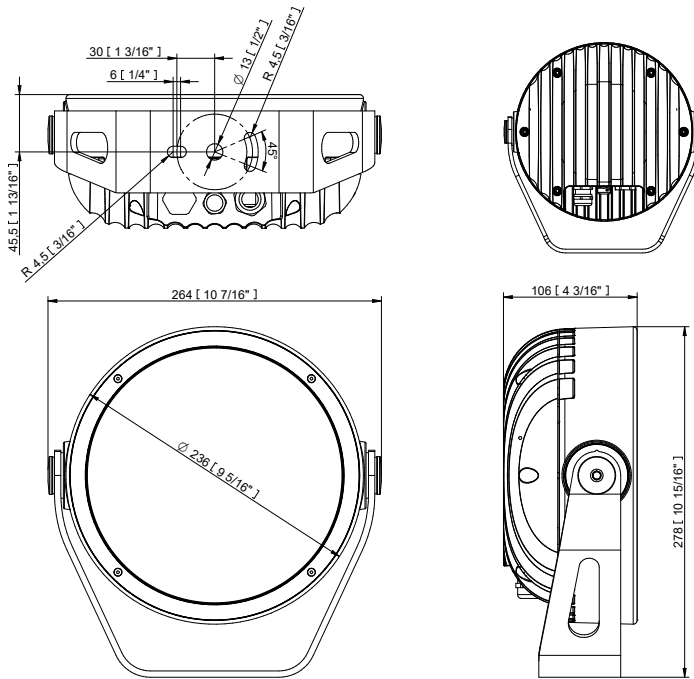

Yoke for Pole Adaptor (with Pole Adaptor / PA)

Example of ordering code: Calumma Remote M SC RGBCW 15° PA

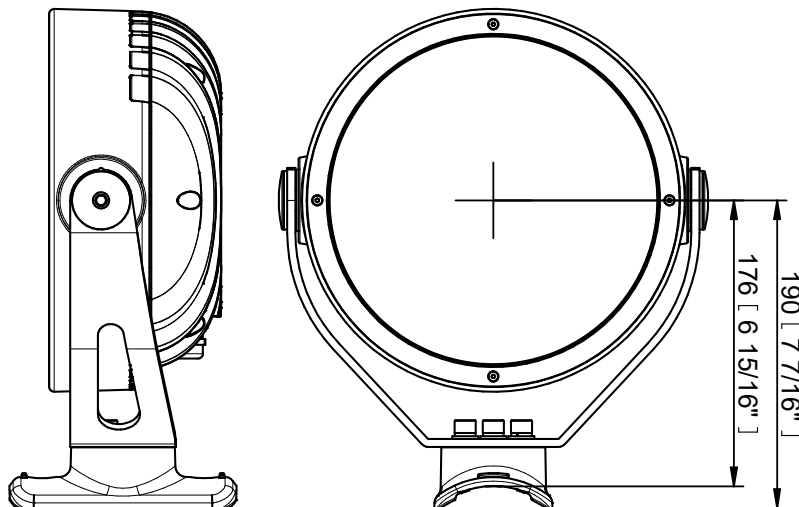

SPECIFICATION SHEET CALUMMA REMOTE M SC

Outdoor Foil Holder for Calumma M „OFH“ version only (for permanent installation)

Example of ordering code: Calumma Remote M SC CE RGBCW 10° RAL9007 OFH

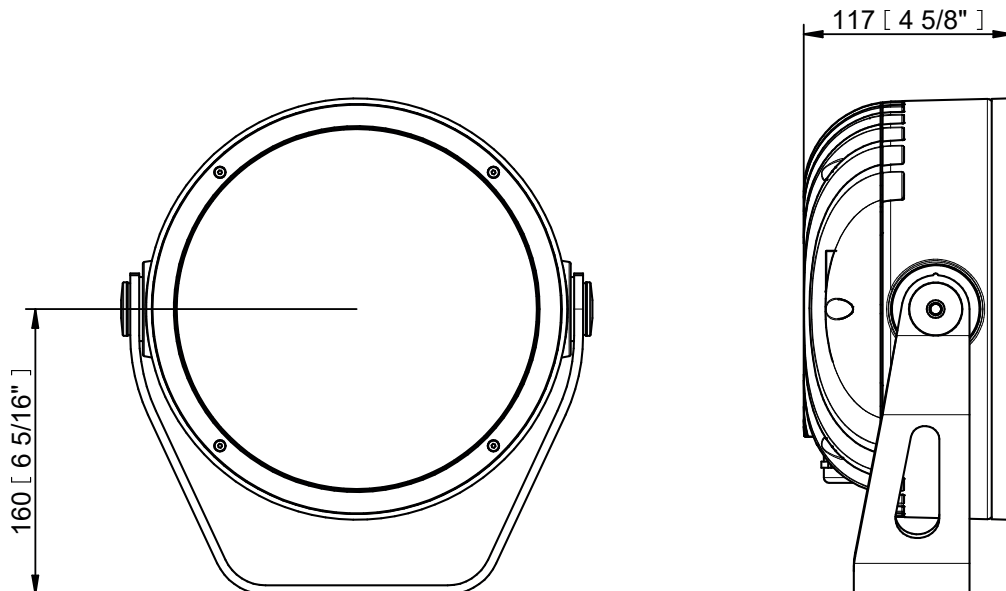

ACCESSORIES

Outdoor Foil Holder for Calumma M

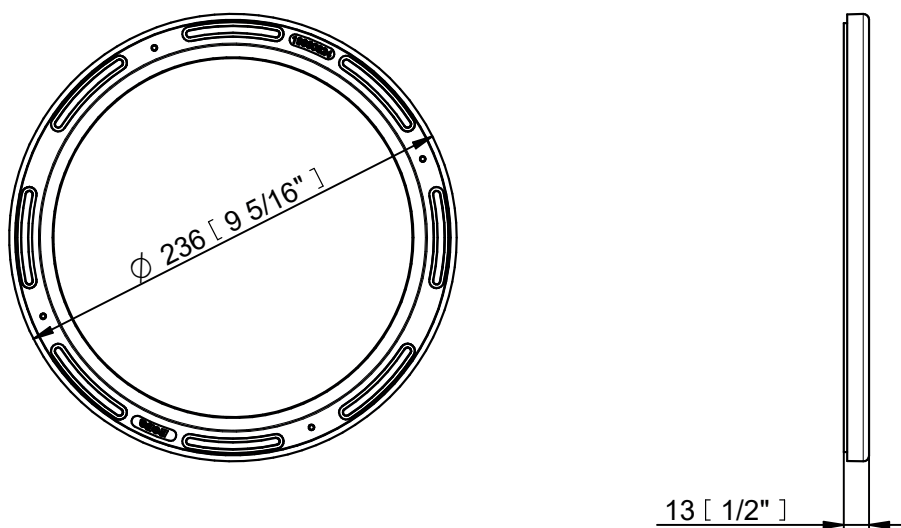

ACCESSORIES

Top Hat

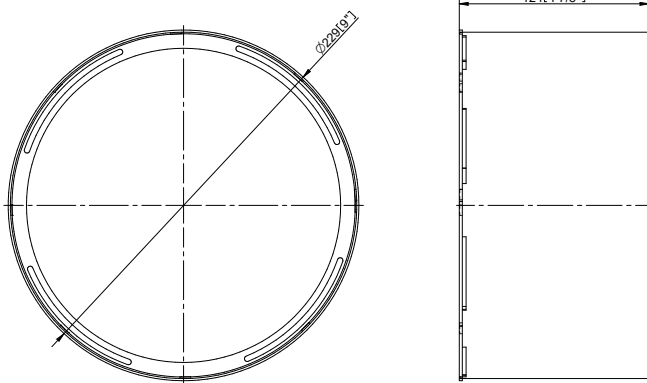

Half Top Hat

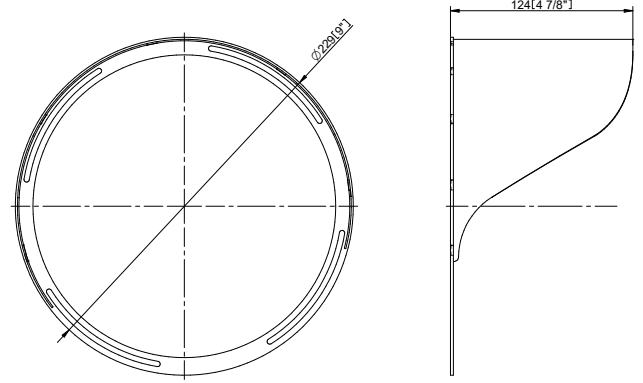

Floor Stand

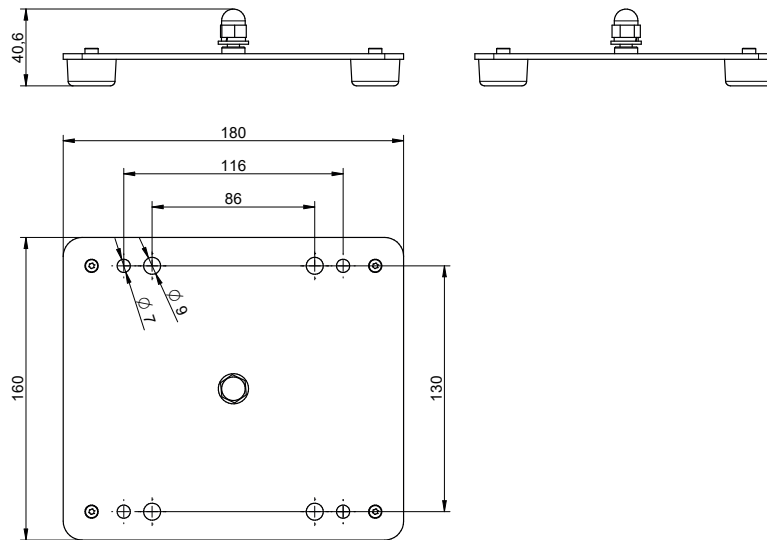

Pole Adaptor

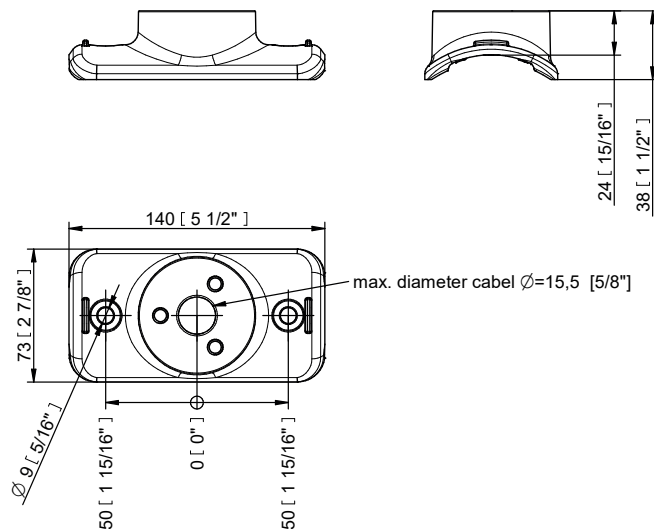

PHOTOMETRIC OVERVIEW

	Lumen Output (lm)		
	RGBCW (W 6500 K)	RGBA	WW (W 3000 K)
10°	3478	2439	4305
15°	3169	2222	3923
25°	3097	2172	3834
30°	3040	2132	3763
45°	3104	2177	3842
65°	3043	2134	3767
100°	3081	2160	3814
10° x 30°, 30° x 10°	3060	2146	3788
10° x 60°, 60° x 10°	3045	2135	3769
15° x 45°, 45° x 15°	3177	2228	3933
30° x 60°, 60° x 30°	3027	2123	3747
30° x 90°, 90° x 30°	2853	2001	3532
15° x 90°, 90° x 15°	2996	2101	3709

BI-SYMMETRICAL BEAM ANGLES

Bi-symmetrical:
10°x30°,
10°x60°,
15°x45°,
15°x90°,
30°x60°,
30°x90°

10°, 15°, 30°

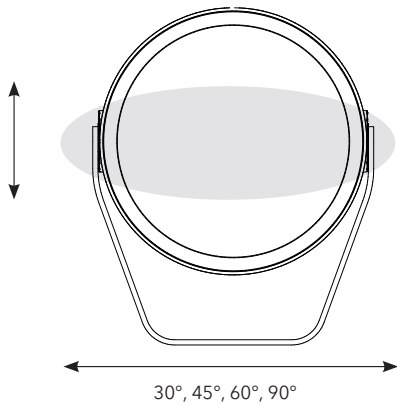

Bi-symmetrical:
30°x10°,
60°x10°,
45°x15°,
90°x15°,
60°x30°,
90°x30°

30°, 45°, 60°, 90°

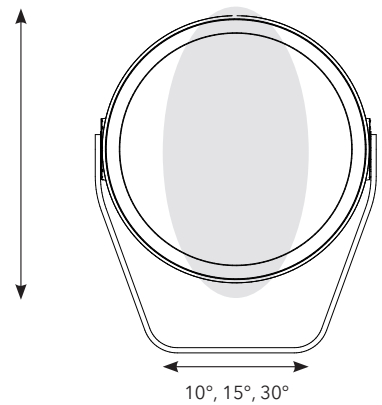

CONTROL AND CONNECTION OPTIONS

Via E-Box REMOTE

- 1) SJTW 5x 14AWG (1305 3336), black
or
On request: Cable SJTW 5x 14AWG (13053697), white
- 2) Junction Box Remote, (4x Output)
- 3) UL 20969 5x 20AWG (13053481), black
or
On request: Cable SJTW 5x 20AWG (13053696) white
- 4) Junction Box Remote, (1x Output)

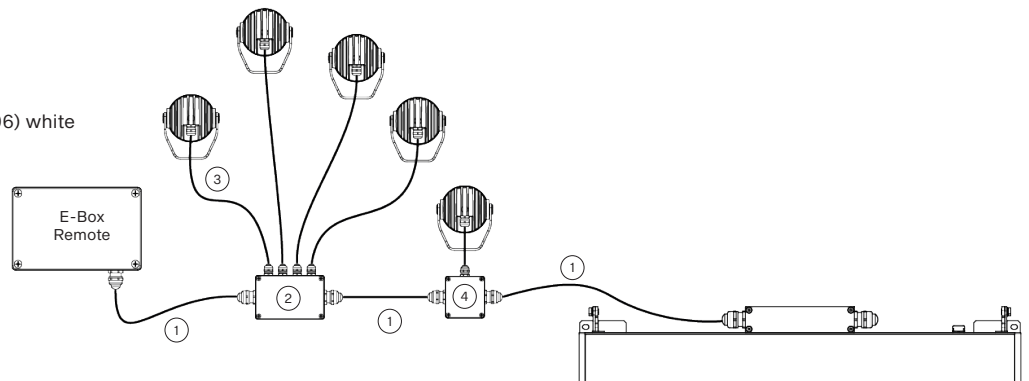

PHOTOMETRIC DATA

Calumma M SC RGBW 6500K 10dg

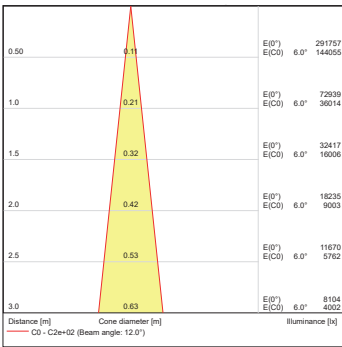
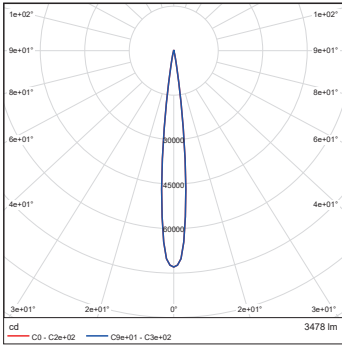

Calumma M SC RGBW 6500K 15dg

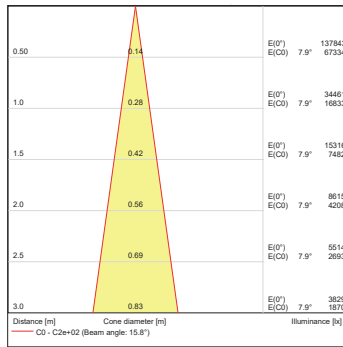
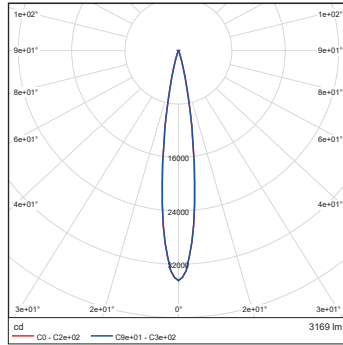

Calumma M SC RGBW 6500K 25dg

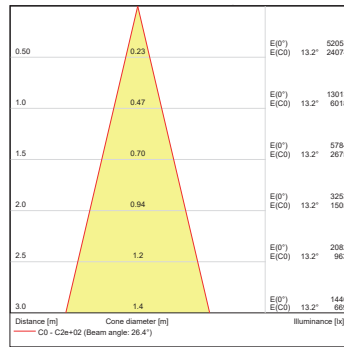
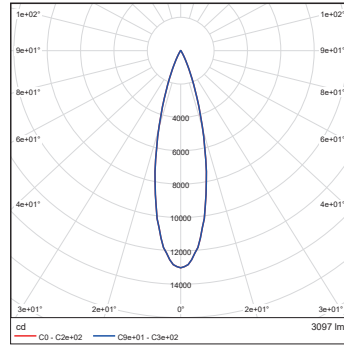

Calumma M SC RGBW 6500K 30dg

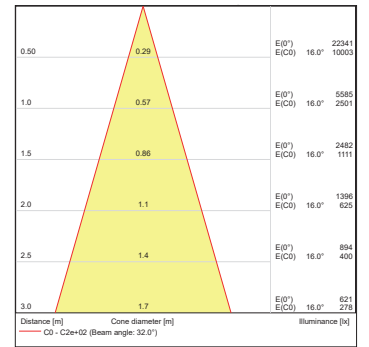
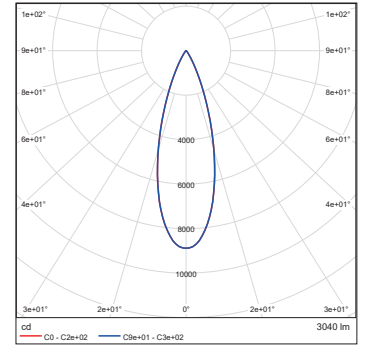

Calumma M SC RGBW 6500K 45dg

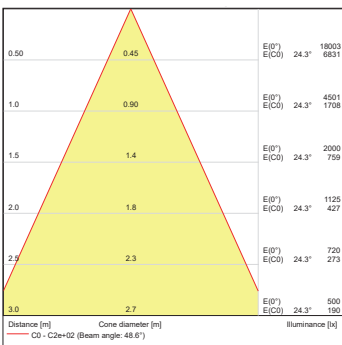
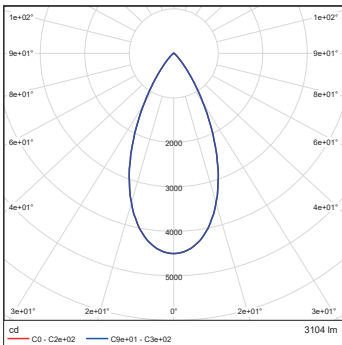

Calumma M SC RGBW 6500K 65dg

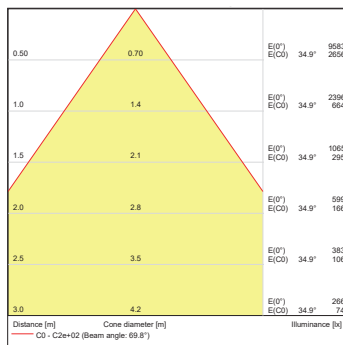
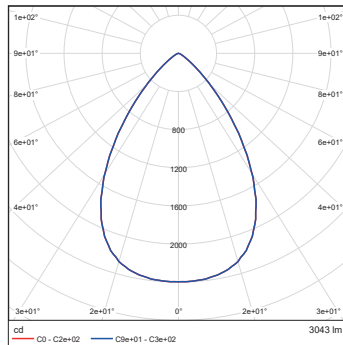

Calumma M SC RGBW 6500K 100dg

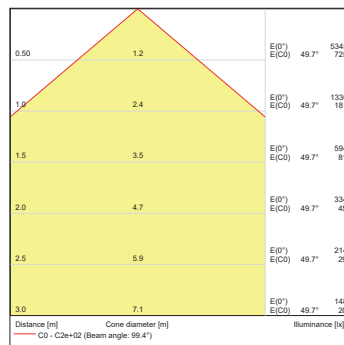
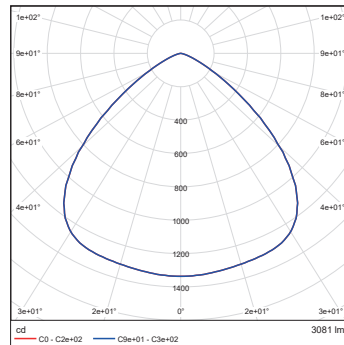

PHOTOMETRIC DATA

Calumma M SC RGBW 6500K
10x30dg

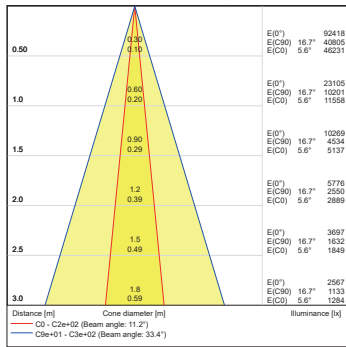
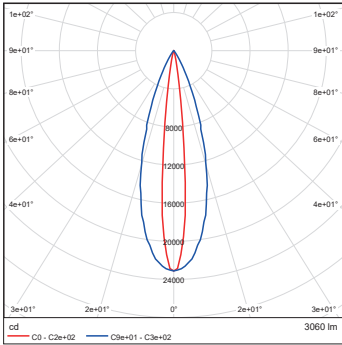

Calumma M SC RGBW 6500K
10x60dg

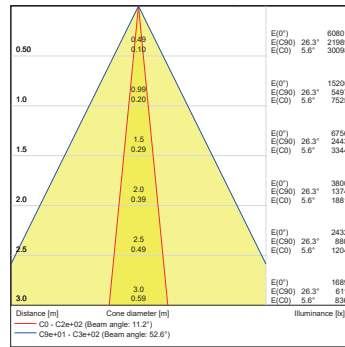
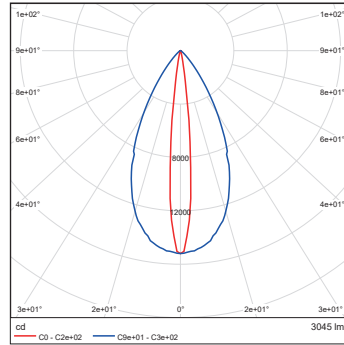

Calumma M SC RGBW 6500K
15x45dg

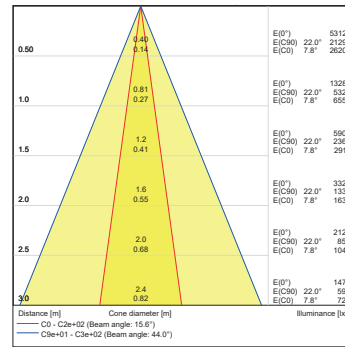
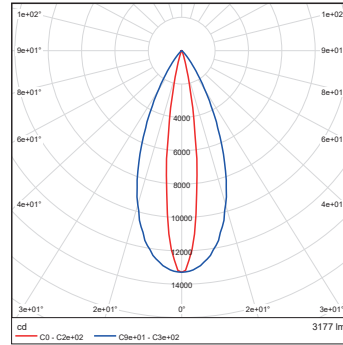

Calumma M SC RGBW 6500K
15x90dg

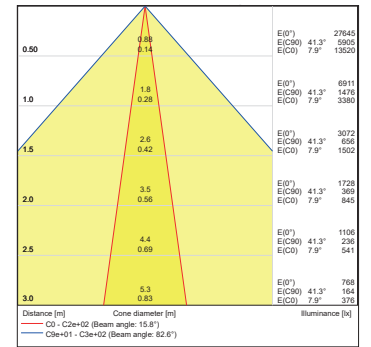
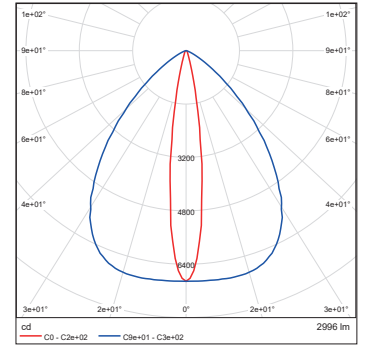

Calumma M SC RGBW 6500K
30x60dg

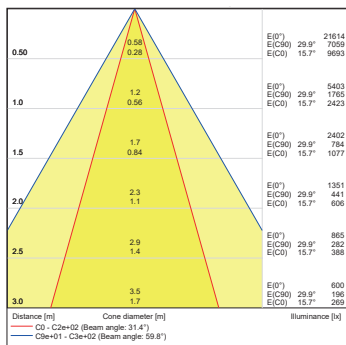
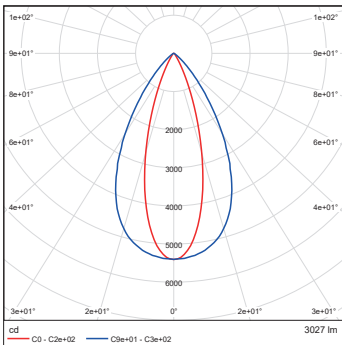

Calumma M SC RGBW 6500K
30x90dg

