

Calumma XL MC Calumma XL SC

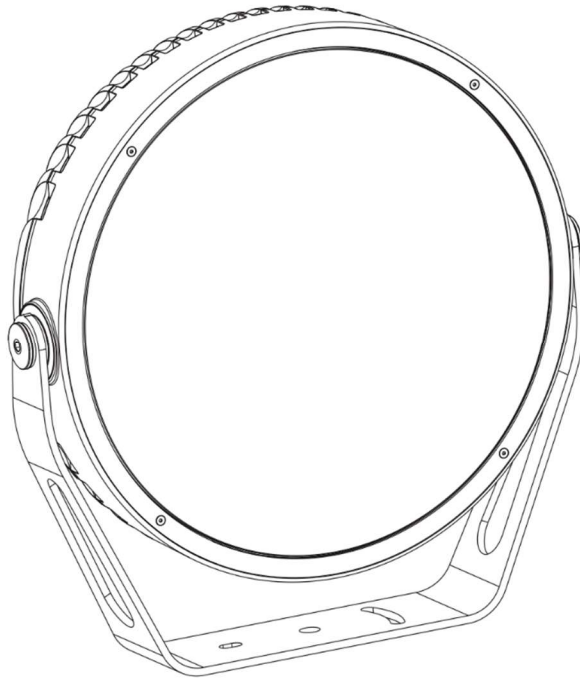

QR code for user manual



USER MANUAL

Version 2.2

Table of contents

1. Safety instructions	3
2. Fixture exterior view	5
3. Installation	5
3.1 Mounting the fixture	5
3.2 Connection to mains	8
3.3 Top hat installation	10
3.4 Half top hat installation	11
3.5 Outdoor foil holder installation	12
4. Control and connection options	14
4.1 DMX or DALI	14
4.2 Wireless DMX	15
4.3 Wireless DMX to wire DMX	16
4.4 Power On/Off	17
4.5 DMX or Ethernet via E-box	18
4.5.1 Booster box	24
4.5.2 Booster box installation	26
4.6 Example of Control panel in RDM manager	28
5. Software update	30
6. Technical specifications	33
7. Cleaning and maintenance	42
7.1 Disposing of the product	42
8. ChangeLog	43

**FOR YOUR OWN SAFETY, PLEASE READ THIS USER MANUAL CAREFULLY
BEFORE POWERING OR INSTALLING YOUR CALUMMA!
Save it for future reference.**

This device has left our premises in absolutely perfect condition. In order to maintain this condition and to ensure safe operation, it is absolutely necessary for the user to follow the safety instructions and warnings written in this manual.

The manufacturer will not accept liability for any resulting damages caused by the non-observance of this manual or any unauthorized modification to the device.

Unauthorized modification will void warranty.

1. Safety instructions

DANGEROUS VOLTAGE CONSTITUTING A RISK OF ELECTRIC SHOCK IS PRESENT WITHIN THIS UNIT!

This fixture should be operated only from the type of power source indicated on the marking label. If you are not sure of the type of power supplied, consult your authorized distributor or local power company.

Always disconnect the fixture from AC power before servicing or cleaning.

Make sure the power/data cable is not damaged by sharp edges.

Do not install the unit near an open flame.

Refer servicing to qualified service personnel.

This fixture falls under protection class I. Therefore this fixture has to be connected to a mains socket outlet with a protective earthing connection.

Do not connect this fixture to a dimmer pack.

LED light emission. Risk of eye injury. Do not look into the beam from a short distance without suitable protective eyewear. Do not look at LEDs with magnifiers or similar optical instruments that may concentrate the light output.

The fixture was designed for outdoor use. This fixture must not be used for underwater installation.

When choosing the installation spot, please make sure that the fixture is not exposed to extreme heat or dust.

Avoid using the unit in locations subject to possible impacts.

The fixture body never must be covered with cloth or other materials when the fixture is under operation.

Only operate the fixture after having checked that the housing is firmly closed and all screws are tightly fastened.

The fixture becomes hot during operation. Allow the fixture to cool approximately 30 minutes prior to servicing or maintenance.

Operate the fixture only after having familiarized yourself with its functions. Do not permit operation by persons not qualified to operate the fixture. Most damages are the result of unprofessional operation!

Please consider that unauthorized modifications on the fixture are forbidden due to safety reasons!

Please use the original packaging if the fixture is to be transported.

If this device will be operated in any way different to the one described in this manual, the product may suffer damages and the warranty becomes void. Furthermore, any other operation may lead to dangers like short-circuit, burns, electric shock etc.

The product (covers and cables) must not be exposed to a high frequency electromagnetic field higher than 3V/m.

Immunity of the equipment is designed according to the standard EN 55035 Electromagnetic compatibility of multimedia equipment - Immunity requirements

Emission of the equipment complies with the standard EN55032 Electromagnetic compatibility of multimedia equipment – Emission Requirements according to class B.

Contains FCC ID: 2A6PL-DMXRDMRW001

Contains IC: 29573-DMXRDMRW001

This device complies with part 15 of the FCC Rules. Operation is subject to the following two conditions: (1) This device may not cause harmful interference, and (2) this device must accept any interference received, including interference that may cause undesired operation.

Changes or modifications not expressly approved by the party responsible for compliance could void the user's authority to operate the equipment.

The [Device] wireless operation is safe and complies to RF Exposure requirements.

This equipment has been tested and found to comply with the limits for a Class B digital device, pursuant to part 15 of the FCC Rules. These limits are designed to provide reasonable protection against harmful interference in a residential installation. This equipment generates, uses and can radiate radio frequency energy and, if not installed and used in accordance with the instructions, may cause harmful interference to radio communications. However, there is no guarantee that interference will not occur in a particular installation. If this equipment does cause harmful interference to radio or television reception, which can be determined by turning the equipment off and on, the user is encouraged to try to correct the interference by one or more of the following measures:

- Reorient or relocate the receiving antenna.
- Increase the separation between the equipment and receiver.
- Connect the equipment into an outlet on a circuit different from that to which the receiver is connected.
- Consult the dealer or an experienced radio/TV technician for help.

Warning for fixtures with Harsh Environment Finish (HEF):

Handle with care!

Avoid any damage to the painted surface.

Damaging the paint may result in corrosion and loss of warranty.

2. Fixture exterior view

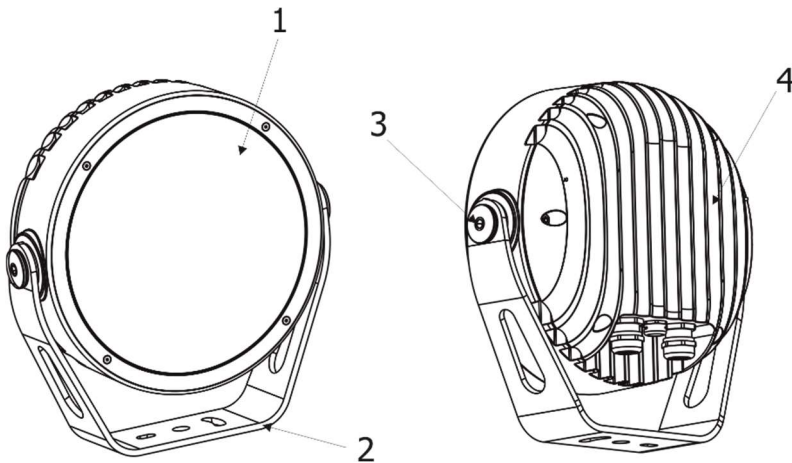

1. Transparent glass cover
2. Mounting yoke
3. Tilt adjusting lock
4. LED module with heat sink

3. Installation

3.1 Mounting the fixture

The Calumma can be fastened in any orientation on a flat, non-flammable surface by means of mounting yoke (2).

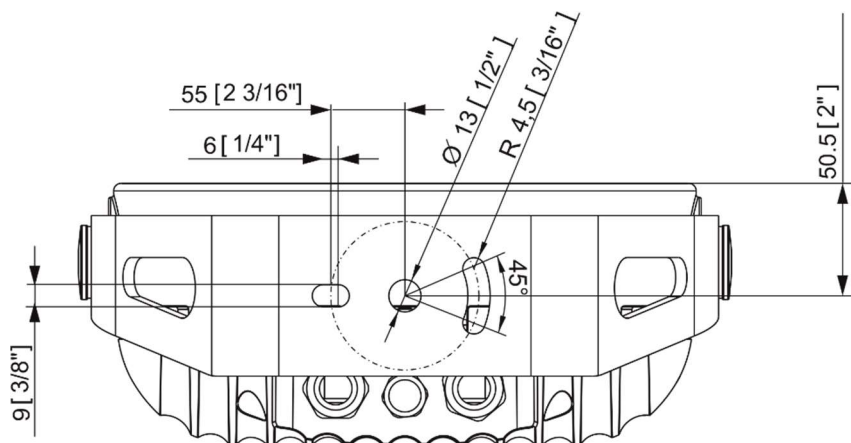

The LED module (4) can be tilted $+180^{\circ}/-180^{\circ}$. Use an Allen key 2.5 for adjusting a LED module position.

Ensure that the structure to which you are attaching the fixture is secure.

Calumma XL

Mounting the fixture via the pole clamp adaptor

The pole clamp adaptor serves as a fastening element for Calumma XL on a pole of diameter of 76-116mm or on the flat pole. The Calumma XL has to be equipped with a modified mounting yoke (P/N 11418771) intended for this way of installation.

The pole clamp adaptor set includes: 1x pole clamp adaptor, 1x rubber cable gland, 3x Allen screw M8x20, 3x flat washer, 3x spring washer, 2x tube spacer.

1. The pole clamp adaptor can be screwed on the pole by means of two screws or fixed by means of a steel clamping tape (max. width of tape=20mm).

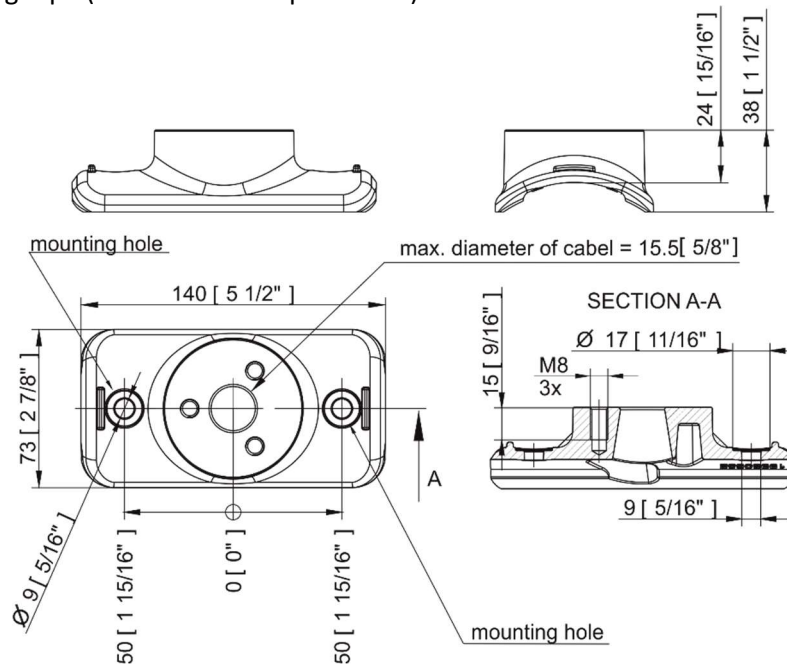

If you use two screws for fastening the pole clamp adaptor on the pole, drill two holes (1) for fastening the pole clamp adaptor on the pole. Diameter of holes depends on material of pole and used screws. Be sure that fastening of the pole clamp adaptor is secure to keep weight of Calumma.

2. Drill the hole (2) for rubber cable gland (diameter of hole=20mm, max. thickness of pole wall= 3.2mm), make drilled hole edges clean (without burrs) and insert the rubber gland into the hole.

Calumma XL

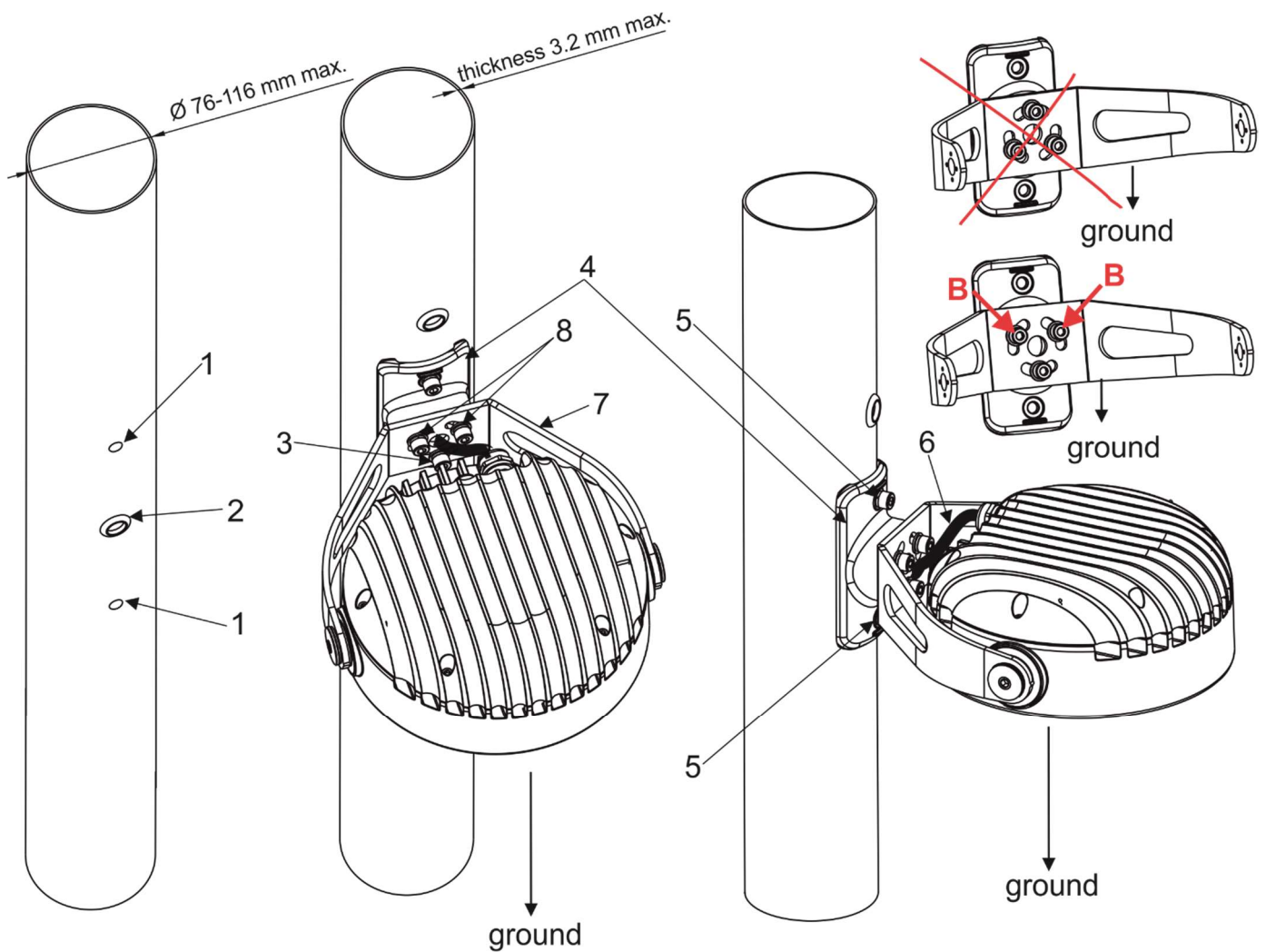

3. Screw the pole clamp adaptor (4) on the pole by means of two screws (5) with spring washers or use a steel clamping tape for fastening the pole clamp adaptor on the pole.
In case of screwing the pole clamp adaptor (7) on a flat surface (pole), two pole spacers have to be inserted under two mounting holes of the pole clamp adaptor (on fastening screws (5)) to fill up space between the pole and the pole clamp adaptor
4. Pass the Calumma cable (6) through mounting yoke (7), pole clamp adaptor (4) and through cable gland (2) into the pole.
5. Screw the Calumma mounting yoke (7) on the pole clamp adaptor (4) by means of three Allen screws M8x20 (3) with washers (Allen screw + spring washer+ flat washer). Keep correct orientation of the fastening screws (3) as drawn on the picture – two screws (B) have to aim upwards, one screw has to be orientated towards ground.
NOTE. Three mounting openings in the mounting yoke allow positioning of the mounting yoke in range of $0^\circ - 360^\circ$.

3.2 Connection to mains

***The unit must be installed by a qualified electrician in accordance with all national and local electrical and construction codes and regulations.
This device falls under class one and must be grounded!***

The Calumma is equipped with auto-switching power supply that automatically adjusts to any 50/60Hz AC power source from 120-277 Volts.

3.2.1 Junction box installation

The junction box falls under protection class I . Therefore, every junction box has to be connected to a mains socket outlet with a protective earthing connection.

1. Unscrew the four screws (1) from the cover (2) on the junction box to get access to the terminal block (3) and two mounting holes of diameter of 4.6 mm (4).
2. Screw the junction box on a non-flammable flat surface.

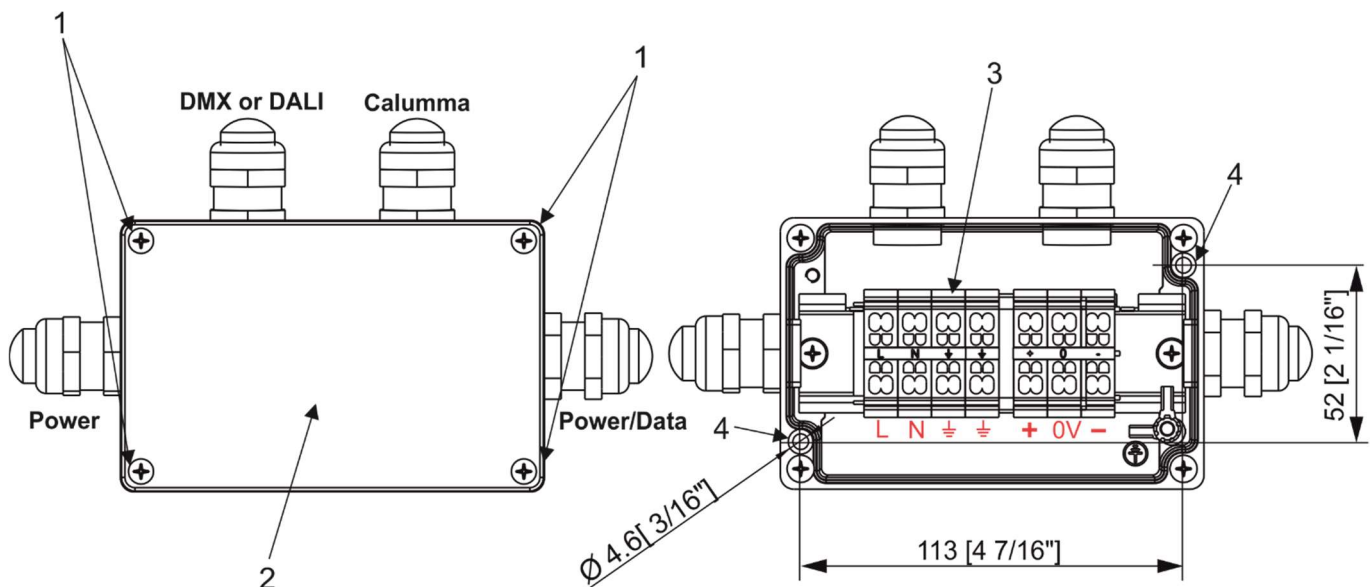

3. Connect cables.

The cable gland M20 x 1.5 with a standard seal serves for a cable of diameter of 7-13mm, for smaller diameter of cable (4-8mm) you have to remove the original seal from the cable gland M20x1.5 and use enclosed reducing seal instead of it. The reducing seal for diameter of cable 4-8mm (P/N 13051388) is enclosed in the Junction box. Remove the end cap from the cable gland before passing the cable.

We recommend to apply an adequate layer of the paste LOCTITE 5331 on the plastic holder of the cable gland before inserting it into the body of the gland.

Cable gland M20x1.5:

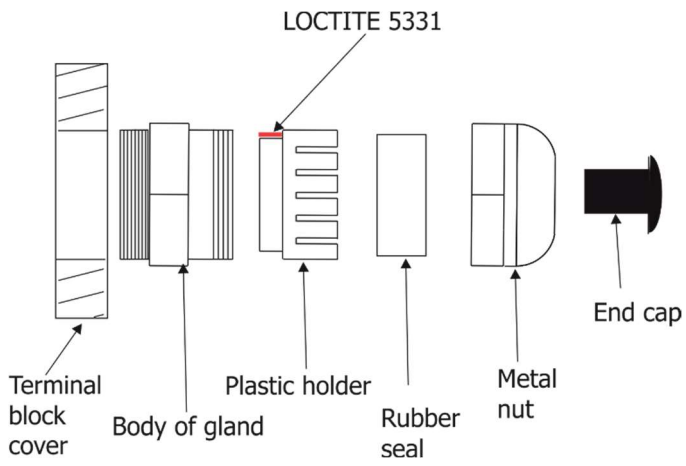

4. Screw the cover (2) back on the junction box.

3.3 Top hat installation

1. Unscrew the four flat-head screws M3x8 (1) from the front of the Calumma and remove the flange (2).
2. Place the top hat (3) on the Calumma and screw it by means of the four flat-head screws M3x8 (1).

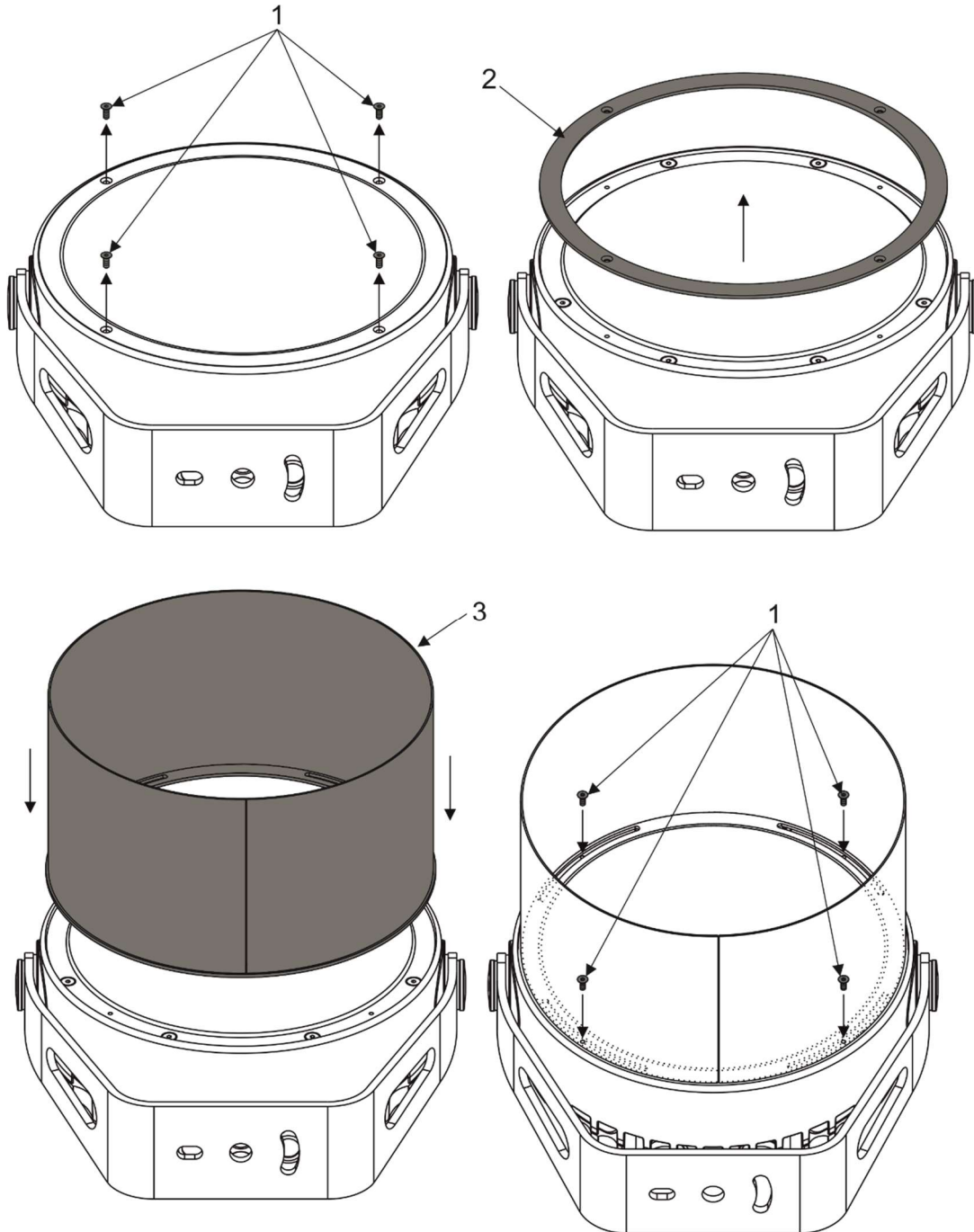

3.4 Half top hat installation

1. Unscrew the four flat-head screws M3x8 (1) from the front of the Calumma and remove the flange (2).
2. Place the half top hat (3) on the Calumma and screw it by means of the four flat-head screws M3x8 (1).

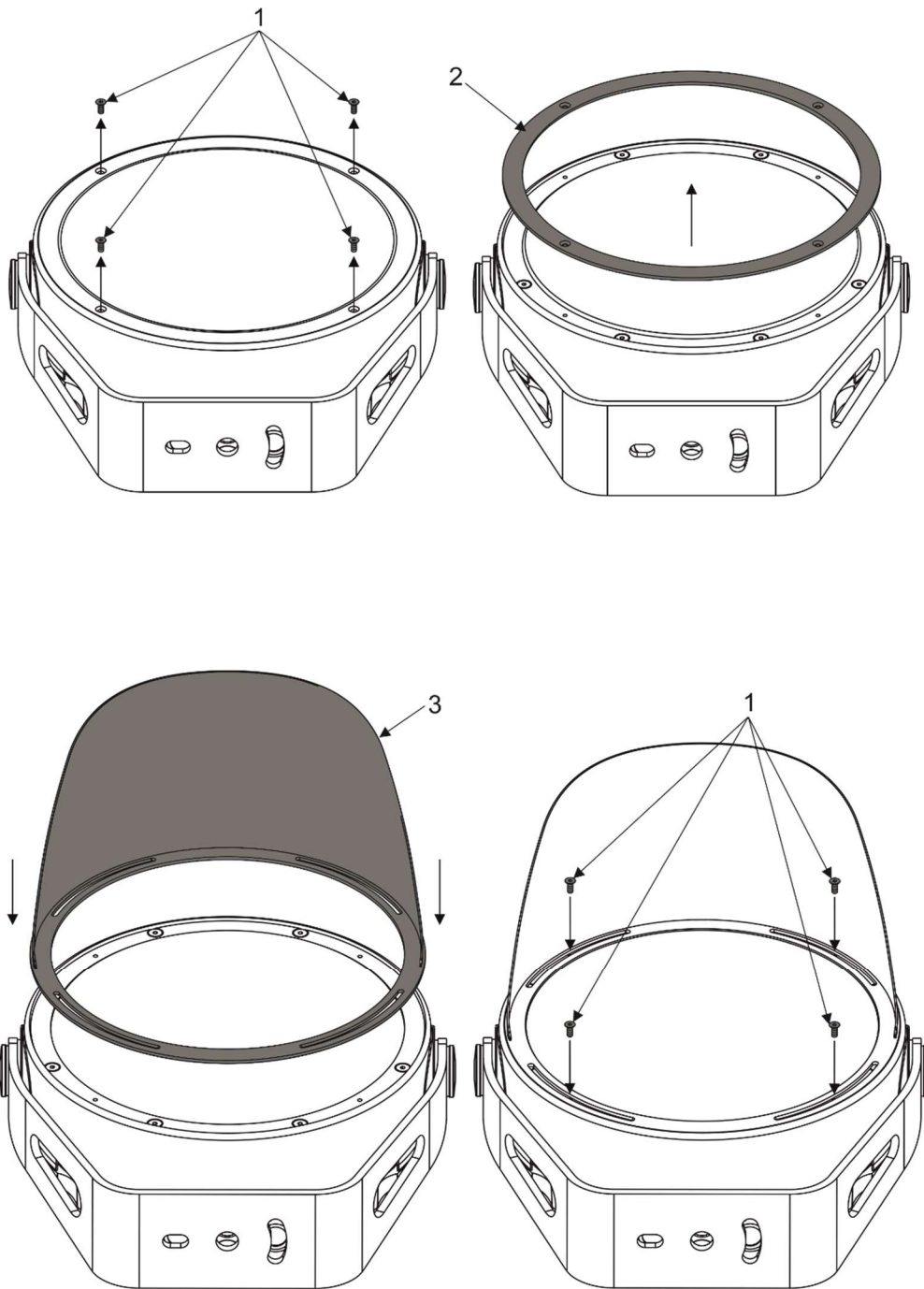

3.5 Outdoor foil holder installation

1. Close the light output from the Calumma.
2. Unscrew the four flat-head screws M3x8, DIN 799, A4 (1) from the front side of the Calumma and remove the flange (2).

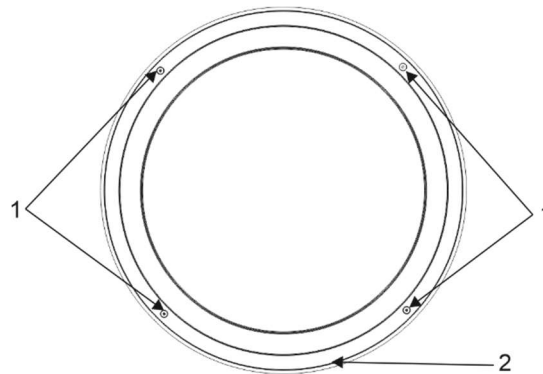

3. Place the optical foil (6) to the outdoor foil holder (4). The optical foil has to be inserted in the rubber holder (7) of the outdoor foil holder (4). The rubber holders allow you to turn the optical foil slightly to desired position if you use bi-symmetrical or asymmetrical foil (light output from the Calumma has to be enabled at adjusting the optical foil position).

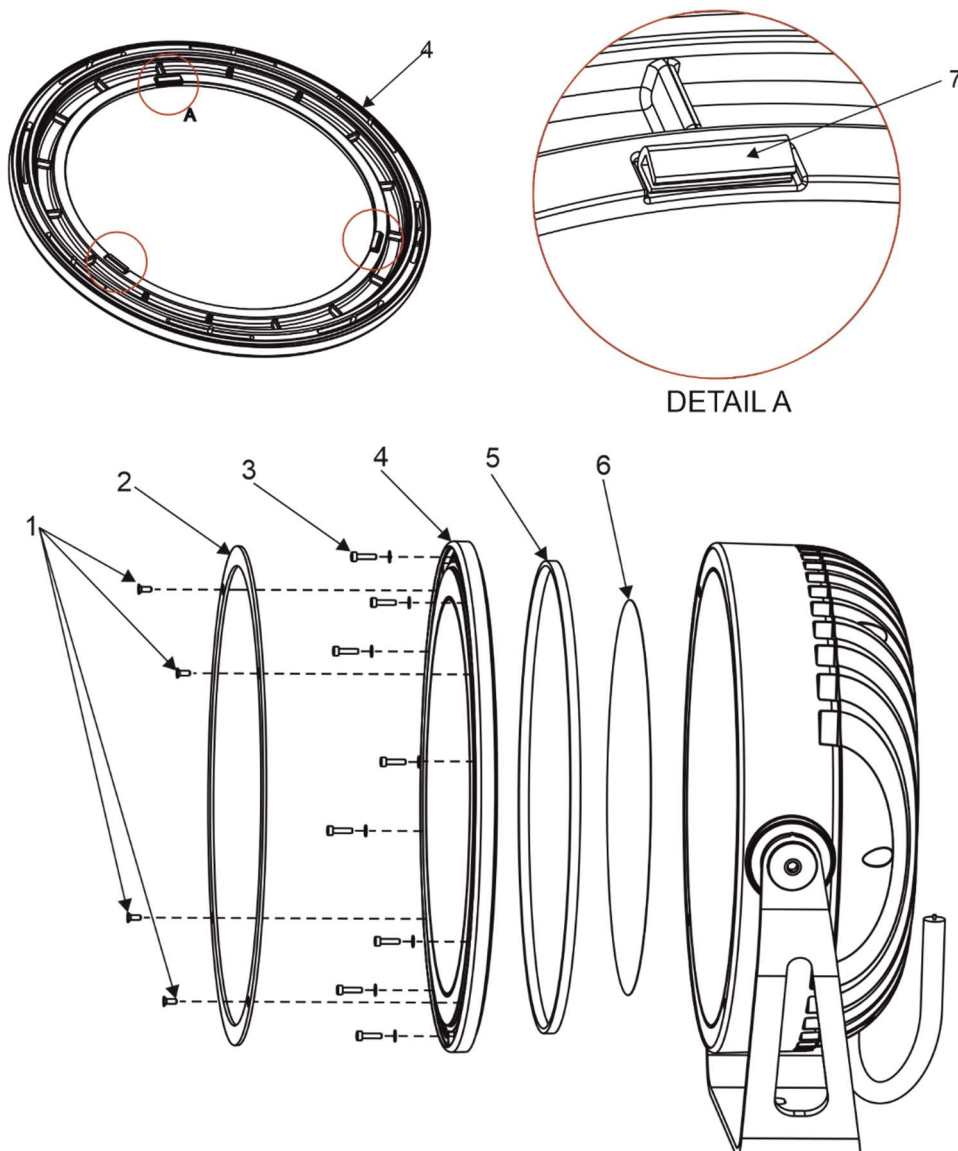

Calumma XL

4. Screw the outdoor foil holder (4) with the optical foil on the Calumma by means of 8 hex socket head screws M3x12, DIN 912, A4 (3). Use a tightening torque 0.5 Nm. The gasket (5) is a part of the outdoor foil holder and is adhered into it. Only check the gasket for signs of deformities or damages and if it is correctly placed in the outdoor foil holder.
5. Screw the flange (2) back on the Calumma by means of four flat-head screws M3x8, DIN 7991, A4 (1), use a tightening torque 1 Nm.

4. Control and connection options

4.1 DMX or DALI

Example

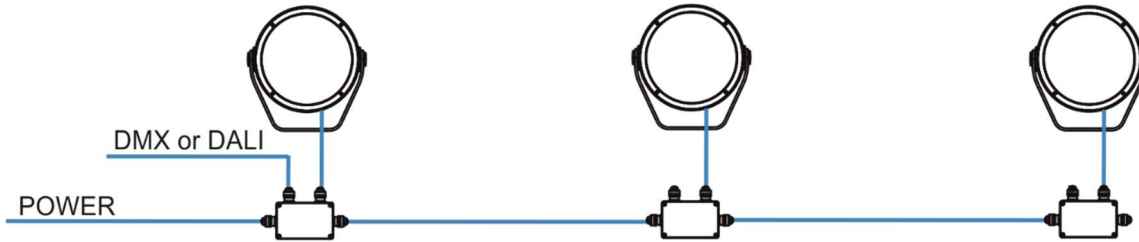

DMX connection (CE)

IF the 5-cored cable Flamar 3x AWG 16 + 1x (2x AWG 24), (P/N 1305 1508) is used for Calumma connection and connection among junction boxes:

Core	Connection	Core	Connection
Black	Live (L)	Red	Data + (+)
Blue	Neutral (N)	White	Data - (-)
Yellow/Green	GND ⊕	Shielding	Data ground (0V)

Up to 32 Calummas can be connected in DMX chain.

NOTE: DMX line of Calummas XL has to be terminated at the last fixture.

EITHER connect a 120 Ohm resistor between terminals + and - in the junction box at last fixture,

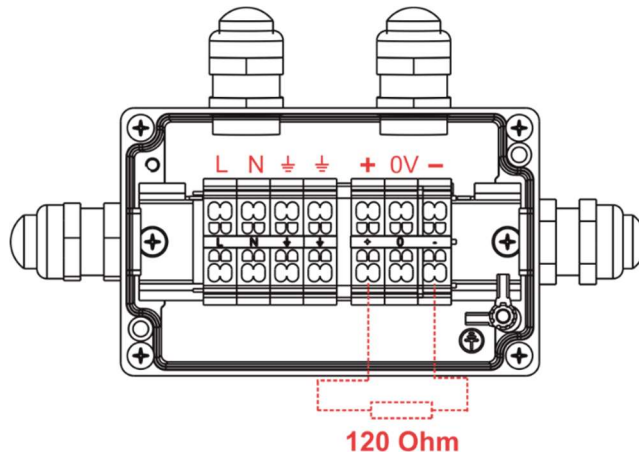

OR terminate via RDM Set the 'Manufacturer PID' 'Terminator active' to '1' at last fixture by means of RDM Control Panel.



Ensure **ONLY** the last fixture in the line is terminated using **ONE** of the above methods!

DALI connection (CE)

Cable 4BD51501-3core+DALI 5X1.5mm2 Hybrid LSZH black (P/N 1305 3693) is intended for Calumma connection and connection among junction boxes.

DALI connection (US)

Cable SJTW 5x 14AWG (P/N 1305 3336) is intended for Calumma connection and connection among junction boxes.

Colors and connection stated in the table below go for both cables stated above.

Core	Connection	Core	Connection
Black	Live (L)	Red	Data
White	Neutral (N)	Orange	Data
Yellow/Green	GND ⊕		

Up to 64 Calummas can be connected in DALI network.

4.2 Wireless DMX

Example

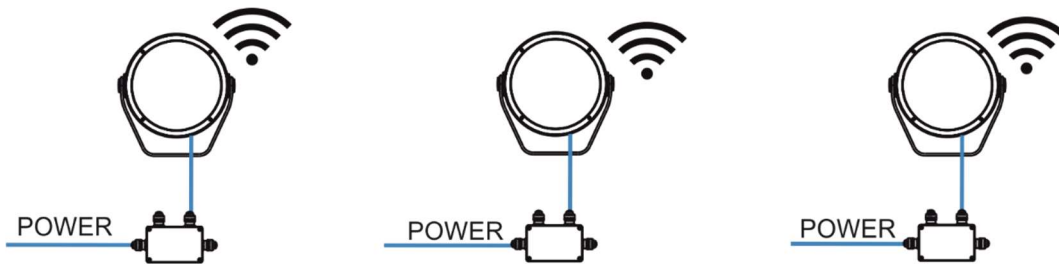

Note: This type of connection is available for M, L, XL versions.

DMX connection (CE)

IF the 5-cored cable Flamar 3x AWG 16 + 1x (2x AWG 24), (P/N 1305 1508) is used for Calumma connection:

Core	Connection	Core	Connection
Black	Live (L)	Red	Data + (+)
Blue	Neutral (N)	White	Data – (-)
Yellow/Green	GND ⊕	Shielding	Data ground (0V)

DMX connection (US)

IF the 6-cored cable SJTW 6x 14AWG, (P/N 1305 3480) is used for Calumma connection:

Core	Connection	Core	Connection
Black	Live (L)	Red	Data + (+)
White	Neutral (N)	Orange	Data – (-)
Yellow/Green	GND ⊕	Blue	Data ground (0V)

4.3 Wireless DMX to wire DMX

Example

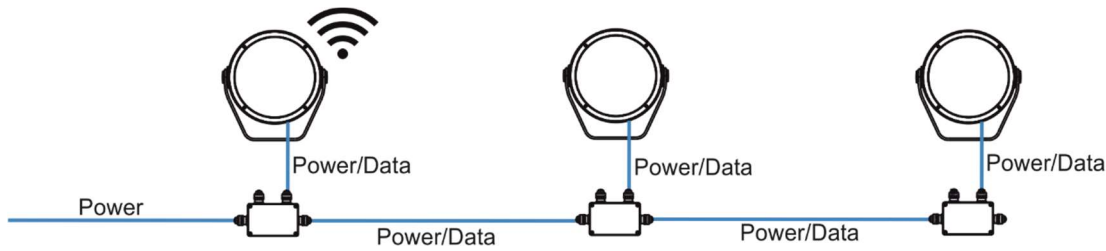

Note: This type of connection must have M, L or XL versions as the first luminaire. Next luminaires in a row could be chosen from S, M, L or XL versions. . The function „wireless DMX → wire DMX output“ cannot be switched off.

DMX connection (CE)

IF the 5-cored cable Flamar 3x AWG 16 + 1x (2x AWG 24), (P/N 1305 1508) is used for Calumma connection and connection among junction boxes:

Core	Connection	Core	Connection
Black	Live (L)	Red	Data + (+)
Blue	Neutral (N)	White	Data – (-)
Yellow/Green	GND ⊕	Shielding	Data ground (0V)

Up to 32 Calummas can be connected in DMX chain.

DMX connection (US)

IF the 6-cored cable SJTW 6x 14AWG, (P/N 1305 3480) is used for Calumma connection and connection among junction boxes:

Core	Connection	Core	Connection
Black	Live (L)	Red	Data + (+)
White	Neutral (N)	Orange	Data – (-)
Yellow/Green	GND ⊕	Blue	Data ground (0V)

4.4 Power On/Off

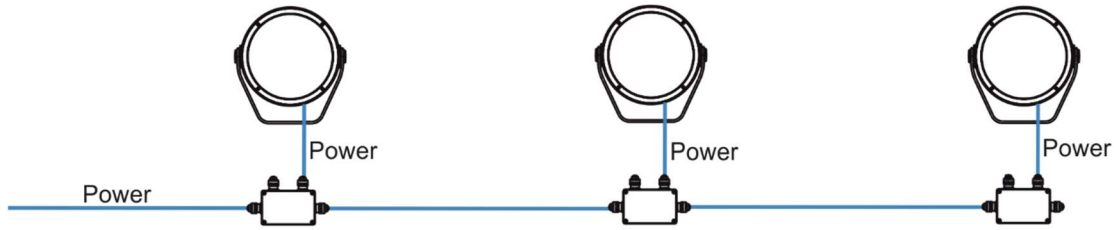

Note: This type of connection is available for single chip (SC) versions only – pure white or single colour. Non dimmable.

Input voltage: 120-277V

Power On/Off connection (CE)

3-cored cable H07BB-F 3G 1.5 (P/N 1305 1443)

Core	Connection
Brown	Live (L)
Light Blue	Neutral (N)
Yellow/Green	GND ⊕

Power On/Off connection (US)

3-cored cable SEOOW power 3x16 AWG (P/N 13051558-1)

Core	Connection
Black	Live (L)
White	Neutral (N)
Green	GND ⊕

4.5 DMX or Ethernet via E-box

The E-box menu allows you to switch connected Calummas to the two modes:

Standard - LED modules are switched to an internal serial connection. DMX addressing of connected LED modules is made automatically (default DMX address = 1), changes can be done by the E-box menu or by RDM.

Pass-Thr - (Pass through). LED modules are switched to an internal parallel connection. DMX addressing of connected LED modules has to be done manually by means of the Robe Universal and the software RDM Manager.

Example with junction boxes

Pass Through mode is intended for this connection. Max. 32 fixtures can be connected to one LED output of the E-Box (Star, Daisy, Lite) in this mode.

NOTE. Each DMX line of Calummas XL has to be terminated at the last fixture. Please see instructions in chapter 4.1 DMX or DALI.

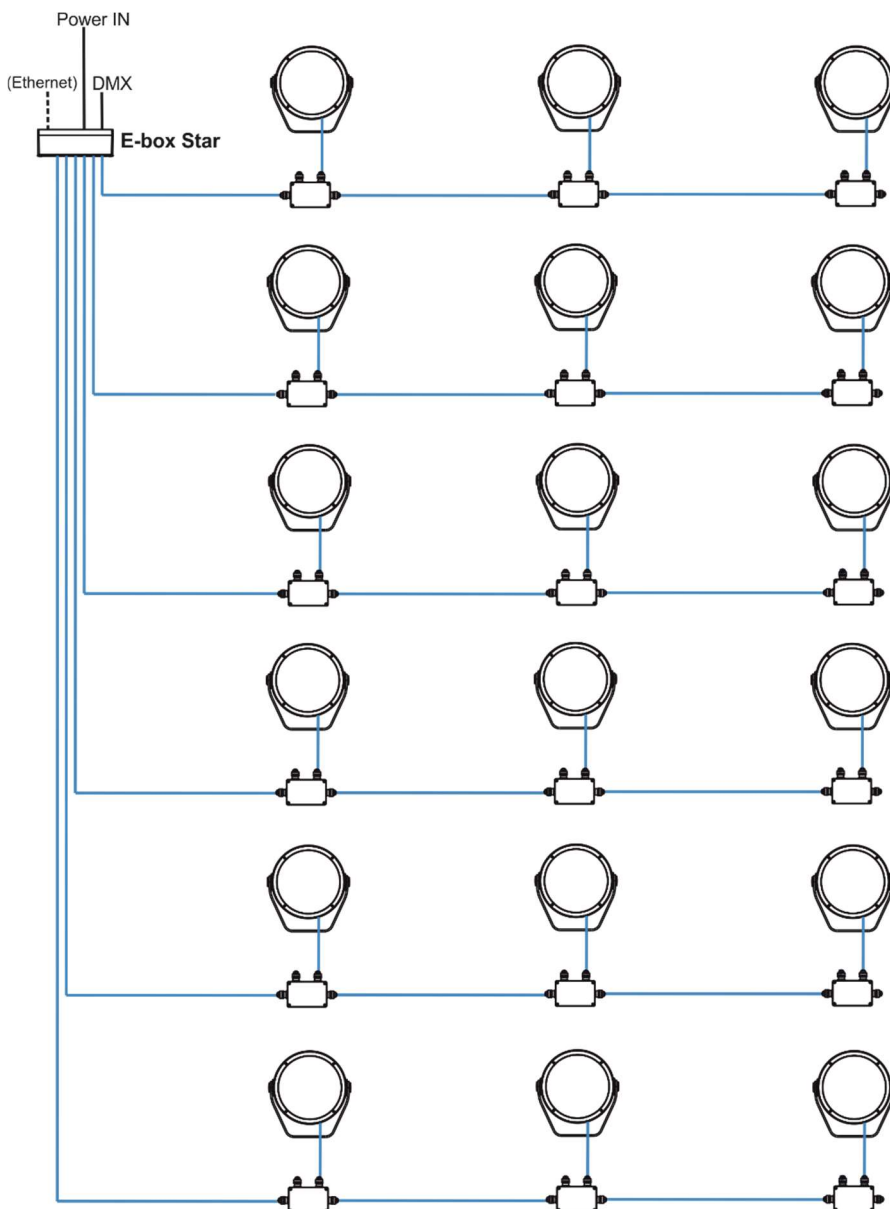

Calumma XL

CE version

IF the 5-cored cable Flamar 3x AWG 16 + 1x (2x AWG 24), (P/N 1305 1508) is used for Calumma connection and connection among junction boxes:

Core	Connection	Core	Connection
Black	Live (L)	Red	Data + (+)
Blue	Neutral (N)	White	Data – (-)
Yellow/Green	GND ⊕	Shielding	Data ground (0V)

US version

IF the 6-cored cable SJTW 6x 14AWG, (P/N 1305 3480) is used for Calumma connection and connection among junction boxes:

Core	Connection	Core	Connection
Black	Live (L)	Red	Data + (+)
White	Neutral (N)	Orange	Data – (-)
Yellow/Green	GND ⊕	Blue	Data ground (0V)

Number of connected Calummas to one E-box output depends on a cable length, power voltage, type of Calumma and E-box operation mode.

The tables below state max. theoretical number of Calummas connected to the one LED output of the E-box.

The tables apply for the **Pass-Through mode of E-boxes**.

Calumma XL MC	Voltage			
	120V	190V	230V	277V
Cable length *				
10 m	10	17	20	24
20 m	10	17	20	24
30 m	7	17	20	24
50 m	4	11	16	23
70 m	3	8	12	17
100 m	2	6	8	12

Calumma XL SC	Voltage			
	120V	190V	230V	277V
Cable length *				
10 m	10	16	19	23
20 m	10	16	19	23
30 m	7	16	19	23
50 m	4	10	15	22
70 m	3	7	11	16
100 m	2	5	8	11

Calumma XL

* Cable length is a total cable length between power supply (e.g. E-box) and last connected Calumma.
Example: Total cable length=L1+L2+L3+L4+L5+L6

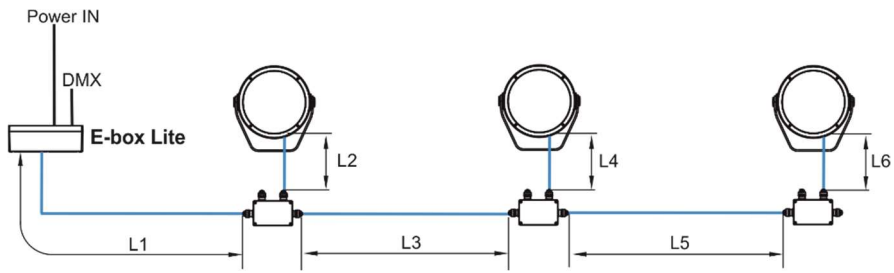

Calumma XL

Example with IN/OUT cables

Standard mode is intended for this connection.

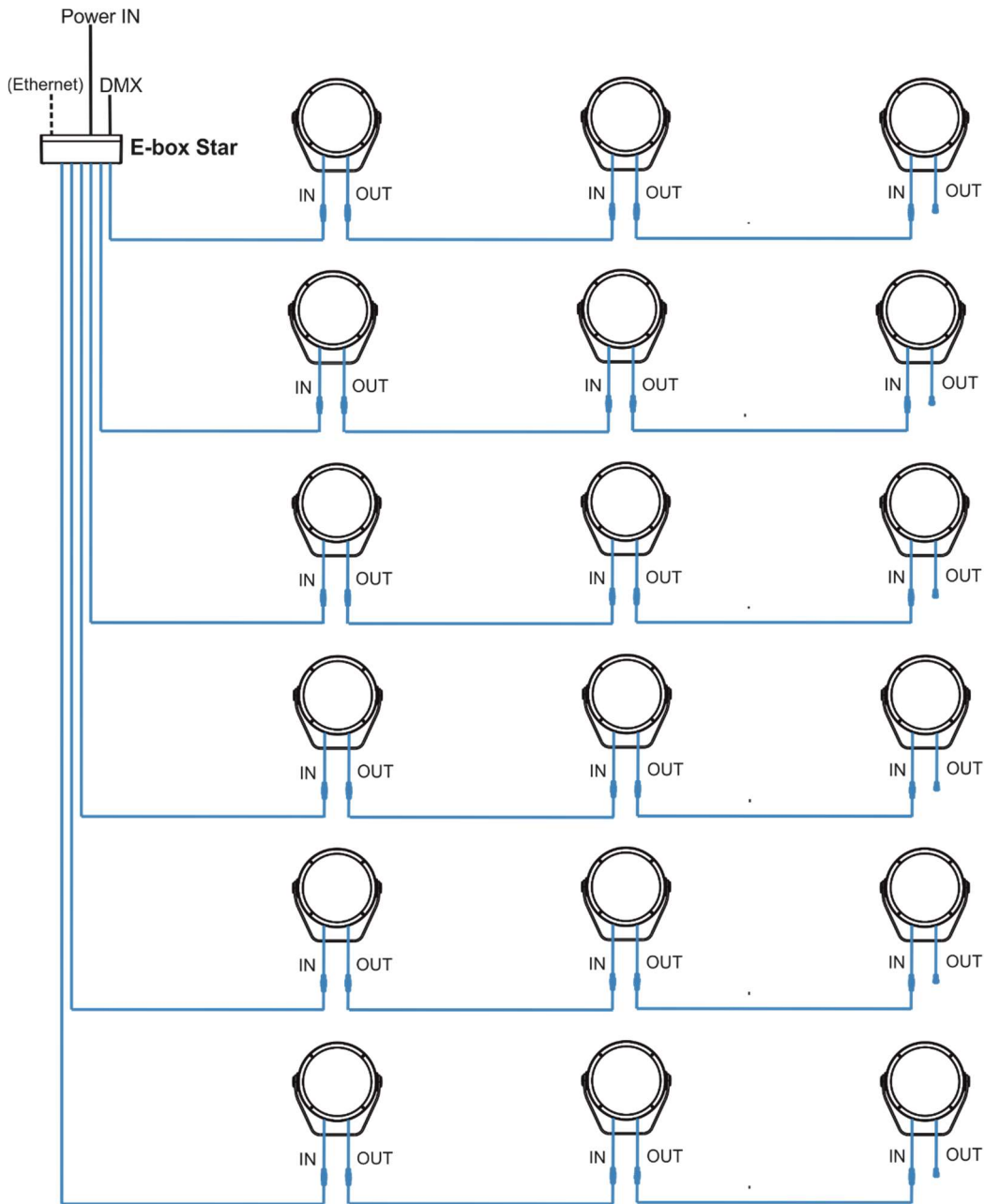

Note. Combination of Calummas and Emineres is also possible

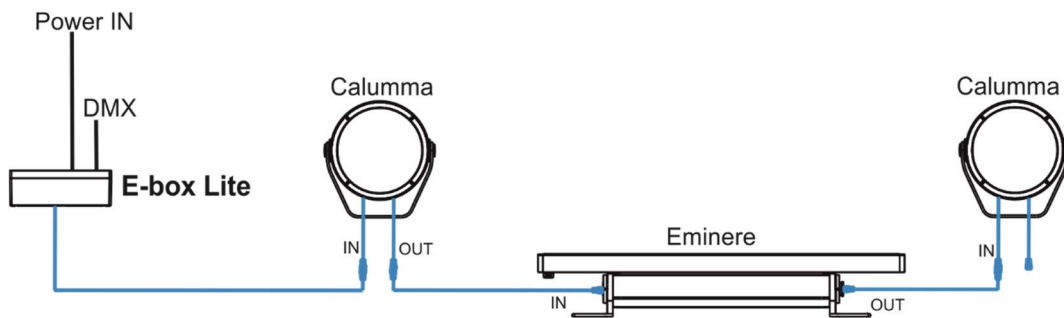

Connection of leader cables

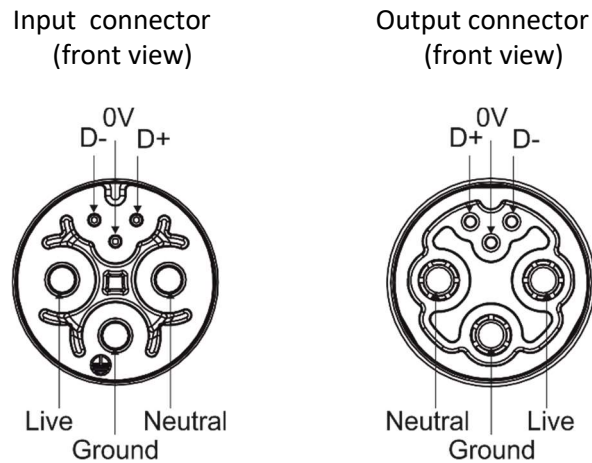

Leader Cable (CE):

Wire	Power Connection	Wire	Data Connection
Brown	Live	Orange	Data -
Blue	Neutral	Purple	Data +
Yellow/Green	Ground (Earth)	Shielding	Data ground (0V)

Fixture's Amphenol connectors are dust and water protected according to IP 67 by mating with related Amphenol connectors. They cannot stay disconnected outdoor.

The output connector at last fixture in the Calumma chain has to always be covered with the water-tight cap to keep declared IP rating.

The Calumma modules with IN/OUT cables should be connected to the E-box which allows power supply of the Calumma modules and their control.

Do not connect (disconnect) Calummas to the E-box or Booster box and each other when they are under voltage!

When you change any setting of the E-box, disconnect the E-box from power and connect it to power again to activate changes which you have made.

Number of connected Calummas to one E-box output depends on a cable length, power voltage, type of Calumma and E-box operation mode.

Calumma XL

The tables below state max. theoretical number of Calummas connected to the one LED output of the E-box without Booster boxes. The following table applies for the **Standard mode of E-boxes**.

Calumma XL MC	Voltage			
	120V	190V	230V	277V
Cable length *				
10 m	10	17	20	24
20 m	10	17	20	24
30 m	7	17	20	24
50 m	4	11	16	23
70 m	3	8	12	17
100 m	2	6	8	12
200 m	1	3	4	6
500 m	0	1	2	2

Calumma XL SC	Voltage			
	120V	190V	230V	277V
Cable length *				
10 m	10	16	19	23
20 m	10	16	19	23
30 m	7	16	19	23
50 m	4	10	15	22
70 m	3	7	11	16
100 m	2	5	8	11
200 m	1	3	4	6
500 m	0	1	2	2

* Cable length is a total cable length between power supply (e.g. E-box) and last connected Calumma.
 Example: Total cable length=L1+L2+L3

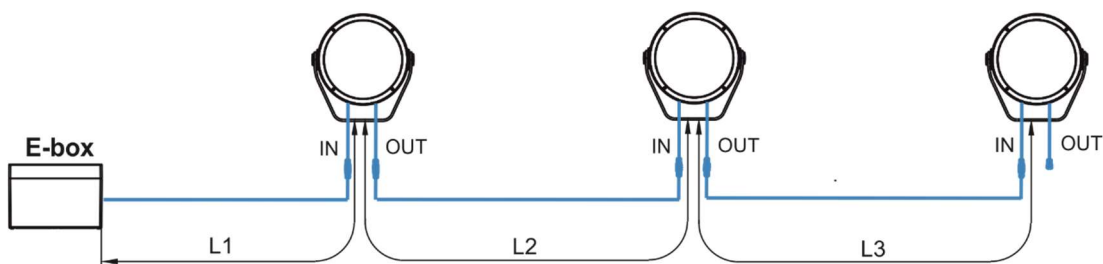

Notice for the E-box Star: The tables above state max. total number of Calummas connected to 6 LED outputs of the E-box Star (or max. number of Calummas connected to one output if the rest of outputs is not connected).

4.5.1 Booster box

To compensate a voltage drop in large installation, the Booster boxes have to be connected in the chain of Calummas (connected IN/OUT method) at every LED output of the E-box.

The following tables give theoretical numbers of Calummas after which the Booster box has to be installed in the chain of Calummas (at one LED output of the E-box). The following table applies for the Standard mode of E-boxes.

Calumma XL MC	Max. number of Calummas XL MC=191			
	Voltage			
Cable length	120V	190V	230V	277V
10 m	10,20	17	20	24
20 m	10,20,30	17,34	20,40	24,48
30 m	7,14,21,28,35,42,49,56...	17,34,51,68	20,40,60,80	24,48,72
50 m	4,8,12,16,20,24,28,32,36,40,44,48,52,56....	11,22,33,44,55,66,77,88,99,110...	16,32,48,64,80,96,112,	23,46,69,92,115
70 m	3,6,9,12,15,18,21,24,27,30,33,36,39,42,45,48,51,54,57,60,63,66,69,72...	8,16,24,32,40,48,56,64,72,80,88..	12,24,36,48,56,68,80,92,104...	17,34,51,68,85,102,119...
100 m	2,4,6,8,10,12,14,16,18,20...	6,12,18,24,30,36...	8,16,24,32,40,48,56...	12,24,36,48,56,68,80....
200 m	1,2,3,4,5,6,7,8,9,10,11....	3,6,9,12,15,18,21,24,27,30,33,36,39,42,45,48,51,54,57,60,63,66,69,72.....	4,8,12,16,20,24,28,32,36,40,44,48,52,56,60,64,68,72,76,80,84....	6,12,18,24,30,36,42...
500 m	-	1,2,3,4,5,6,7,8,9,10,11....	2,4,6,8,10,12,14,16,18,20...	2,4,6,8,10,12,14,16,18,20...

Calumma XL SC	Max. number of Calummas XL SC=191			
	Voltage			
Cable length	120V	190V	230V	277V
10 m	10,20	16	19	23
20 m	10,20,30,40,50	16,32,48	19,38	23,46
30 m	7,14,21,28,35,42,49,56,64...	16,32,48,64	19,38,57,76	23,46,69
50 m	4,8,12,16,20,24,28,32,36,40,44,48,52,56,60,64,68,72,76,80,84....	10,20,30,40,50,60,70,80,90,100...	15,30,45,60,75,90,105..	22,44,66,88,110...
70 m	3,6,9,12,15,18,21,24,27,30,33,36,39,42,45,48,51,54,57,60,63,66,69,72,75,78,81...	7,14,21,28,35,42,49,56,63,70,77,84,91,98...	11,22,33,44,55,66,77,88,99,110,121...	16,32,48,64,80,96,112...

Calumma XL

100 m	2,4,6,8,10,12,14,16,18,20...	5,10,15,20,25,30,35,40,45...	8,16,24,32,40,48,56,64,72,80,88,96...	11,22,33,44,55,66,77,88,99,110,121 ...
200 m	1,2,3,4,5,6,7,8,9,10,11....	3,6,9,12,15,18,21,24,27,30,33,36,39,42,45,48,51,54,57,60,63,66,69,72,75,78,81...	4,8,12,16,20,24,28,32,36,40,44,48,52,56,60,64,68,72,76,80,84.	6,12,18,24,30,36...
500 m	-	1,2,3,4,5,6,7,8,9,10,11....	2,4,6,8,10,12,14,16,18,20...	2,4,6,8,10,12,14,16,18,20... 0...

Example: E-box Daisy, Power supply= 230V, Cable length=70m, fixture=Calumma XL SC.
The Booster box has to be connected after every 11th Calumma XL SC (fixture 11 and fixture 22) from 24 fixtures.

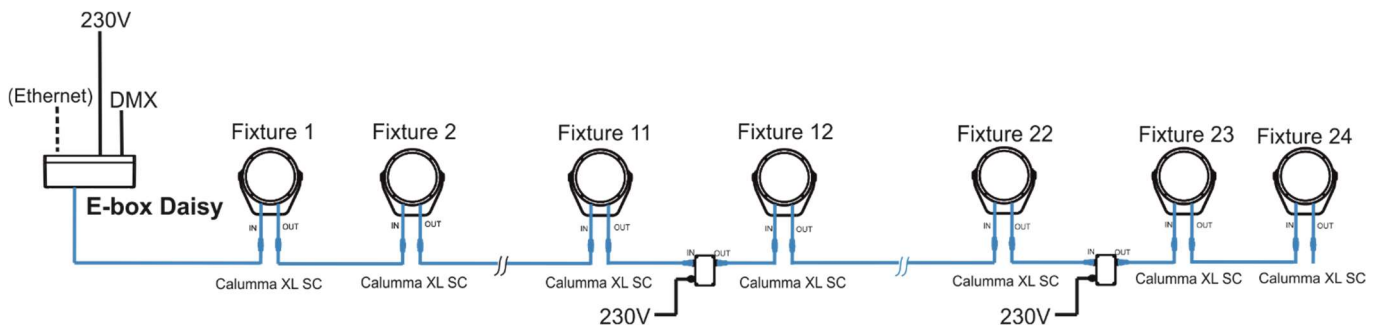

4.5.2 Booster box installation

ALWAYS DISCONNECT THE CALUMMAS FROM MAINS BEFORE CONNECTING/DISCONNECTING THE BOOSTER BOX.

The Booster box falls under protection class I. Therefore, every Booster box has to be connected to a mains socket outlet with a protective earthing connection.

1. Unscrew the four screws (1) from the cover (2) on the Booster box to get access to the terminal block (3) and two mounting holes of diameter of 4.6 mm (4).
2. Screw the Booster box on a non-flammable flat surface and connect cables.

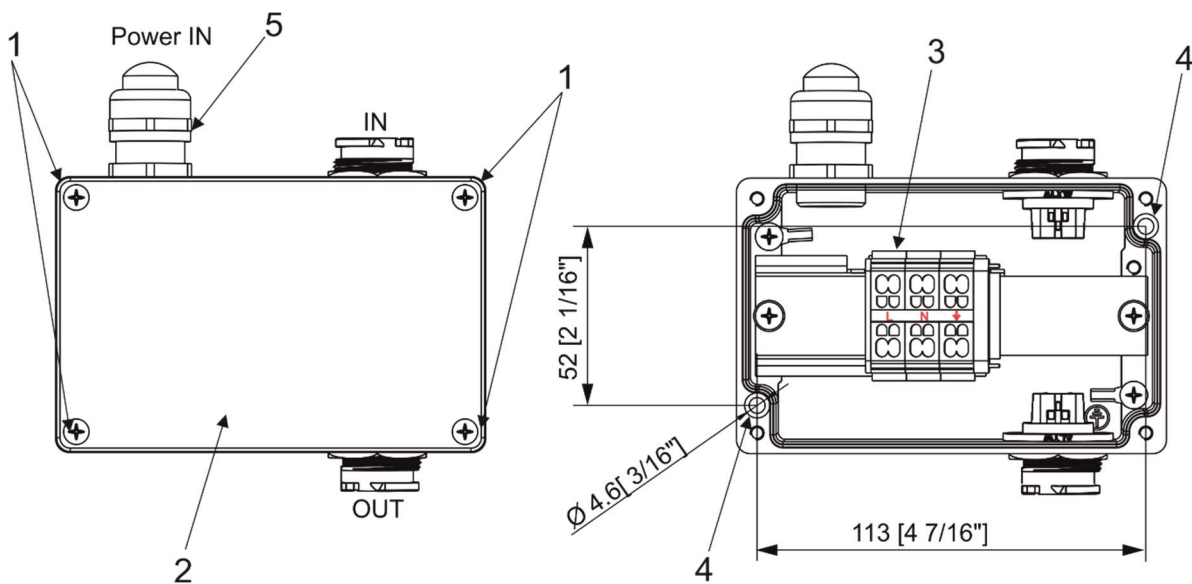

3. Connect power cable.

Remove the end cap from the cable gland before passing the power cable.

The cable gland M20 x 1.5 (5) with a standard seal serves for a cable of diameter of 7-13mm, for smaller diameter of cable (4-8mm) you have to remove the original seal from the cable gland M20 x 1.5 and use the enclosed reducing seal instead of it. The reducing seal for diameter of cable 4-8mm (P/N 13051388) is enclosed in the Booster box.

Power connection

	L	N	⊕ (earth)
Core (CE)	Braun	Blue	Green/yellow

We recommend to apply an adequate layer of the paste LOCTITE 5331 on the plastic holder of the cable gland before inserting it into the body of the gland.

Cable gland M20x1.5

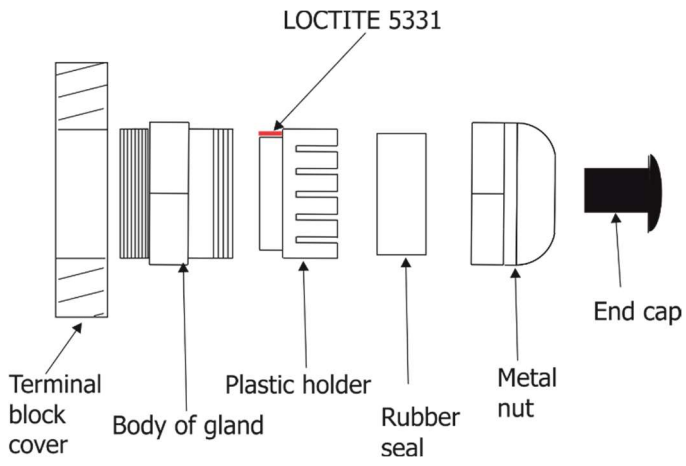

4. Screw the cover (2) back on the Booster box.

4.6 Example of Control panel in RDM manager

The software RDM manager is available on the ROBE website (<https://www.robe.cz/support>), product RUNIT WTX.

Control panel ✖

Device: 52:53-01:2e:00:7f ▶

Product information

RDM protocol version: 0x0100

Device model ID: 0x012e

Product category: 0x0102

Software version: 23

Subdevice count: 0

Sensor count: 2

Manufacturer label: ROBE lighting s.r.o.

Device model description: Calumma

Device label:

DMX512 setup

DMX512 footprint: 4

Current personality:

Personalities count: 16

DMX address:

Power/Lamp setup

Device hours: 3728

Configuration

Factory defaults:

Control

Identify device:

Display settings

Manufacturer PIDs

LED calibration 4byte HEX! (RGBW/RGBA): (hex)

Insect friendly light (0 = off, 1 = on): (hex)

WiFi unlink (1-unl): (hex)

Terminator active (0-dis 1-en): (hex)

Green arrow ▶ saves changes made in the Control panel to the Calumma.

Manufacturer PIDs

LED calibration 4byte HEX! (RGBW/RGBA) - the item shows 4 bytes of calibration values for calibrated white colours of RGBW(RGBA) Calumma.

E.g.



CTC channel has to be set to some calibrated white colour (21 DMX-1800K, 66 DMX-2700K, 91 DMX-3200K, 141 DMX-4200K, 211 DMX-5600K, 255 DMX-6500K) otherwise the item shows values "ff ff ff ff" (and calibration values cannot be saved to the Calumma).

Warning!

Changing and saving values in this item will affect calibrated white colour(s) of the Calumma .

Insect friendly light - the item effects RGBA Calumma only. If the item is on, blue colour is not used in calibrated white colours. This modification of white lights results in a smaller attraction of white light for insects (mosquitos, moths..). The function is also available from DMX chart (channel Special Function, range 7-10 DMX).

WiFi unlink - the item allows you to unlink the Calumma from DMX transmitter (wireless DMX version only)

Terminator active - the item allows you to terminate line of Calummas at last Calumma.

5. Software update

Software update of Calumma module has to be done by means of the software ROBE Uploader running on PC. The ROBE Uploader is a software for automatized software update of ROBE fixtures. The ROBE Uploader switches Calummas to the update mode automatically.

Please see <https://www.robe.cz/robe-uploader/> for more information.

Note: Calumma modules in DALI connection and ON/OFF connection cannot be updated.

The software update depends on a method of Calummas connection.

DMX or Ethernet connection via E-box

If the option **Standard** is selected from the menu **E-box mode**, the E-box will be updated including connected Calumma XL modules. You have to use the file EminereEbox.lib in the ROBE Uploader for this operating mode. The Standard mode is usually used in IN/OUT connection (without junction boxes).

If the option **Pass-Thr** is selected from the menu **E-box mode**, you have to do the following steps to update Calummas XL including the E-box. The Pass-Through mode is usually used in connection with junction boxes.

1. Update connected LED modules by means of the file Calumma.lib in the ROBE Uploader.
2. Set the E-box to the Standard mode and switch it off/on. Use the file EminereEbox.lib in the ROBE Uploader for software update of the E-box.
3. After updating the E-box, set the E-box to the Pass-Through mode and switch it off/on.

For more information about updating please see the E-box Lite/Daisy/Star user manual.

Examples:

1. By means of DMX connection and Robe Universal Interface, IN/OUT connection.

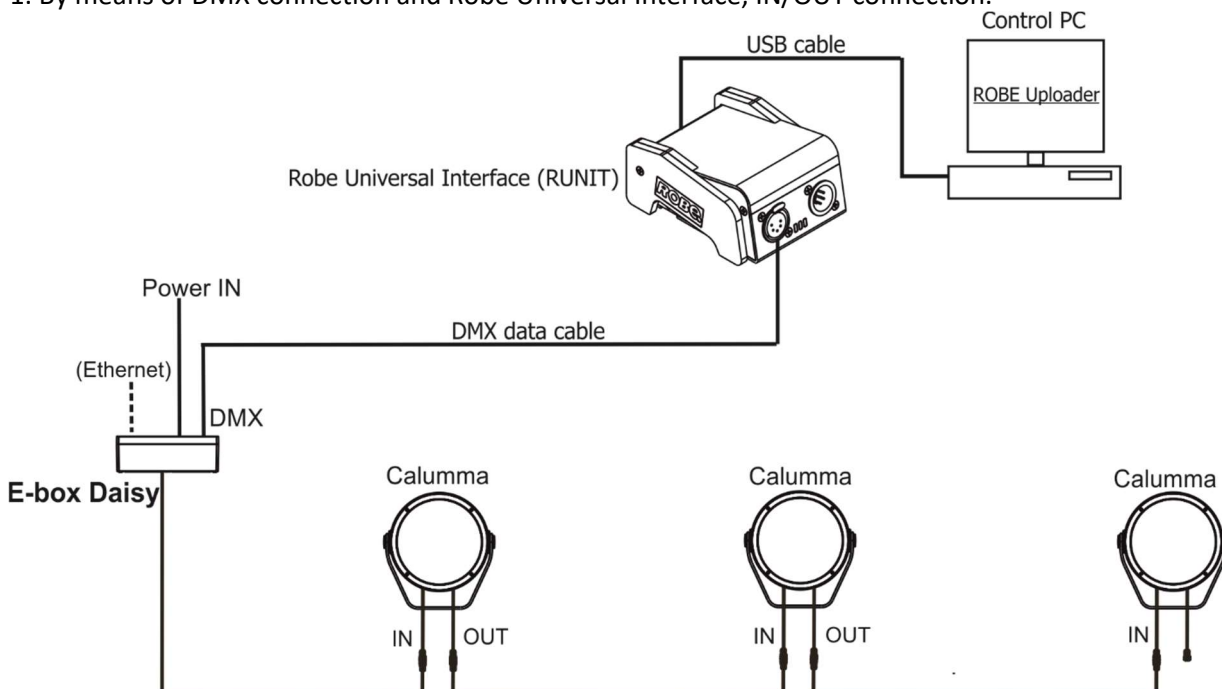

Calumma XL

2. By means of the Ethernet connection, IN/OUT connection.

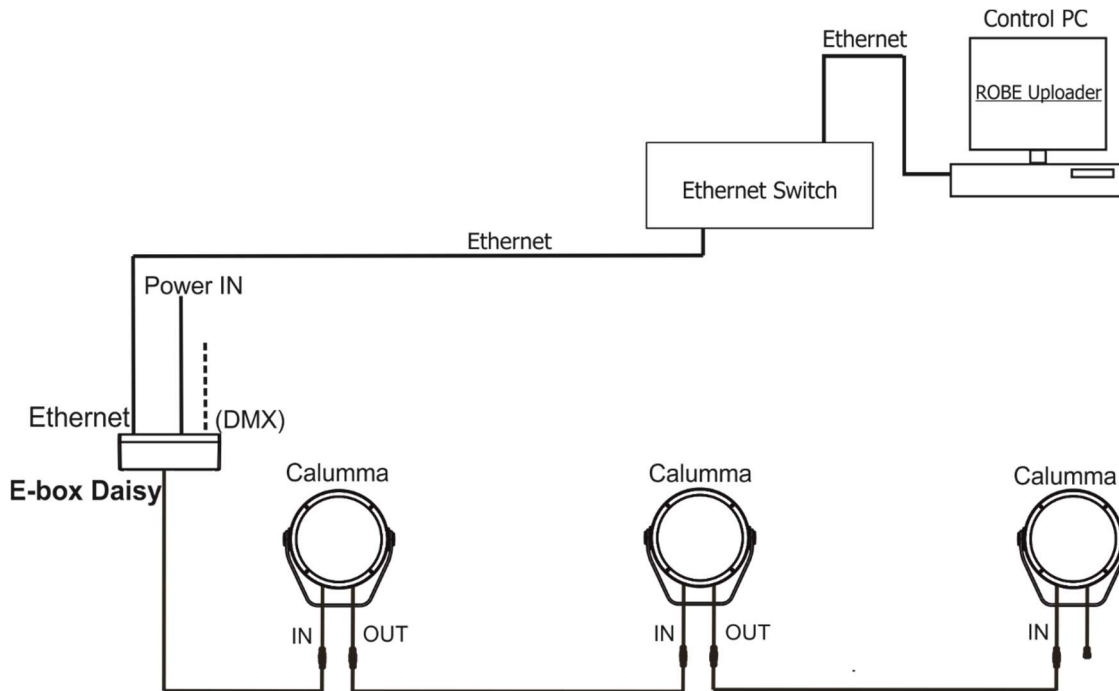

3. By means of DMX connection and Robe Universal Interface. Connection via junction boxes.

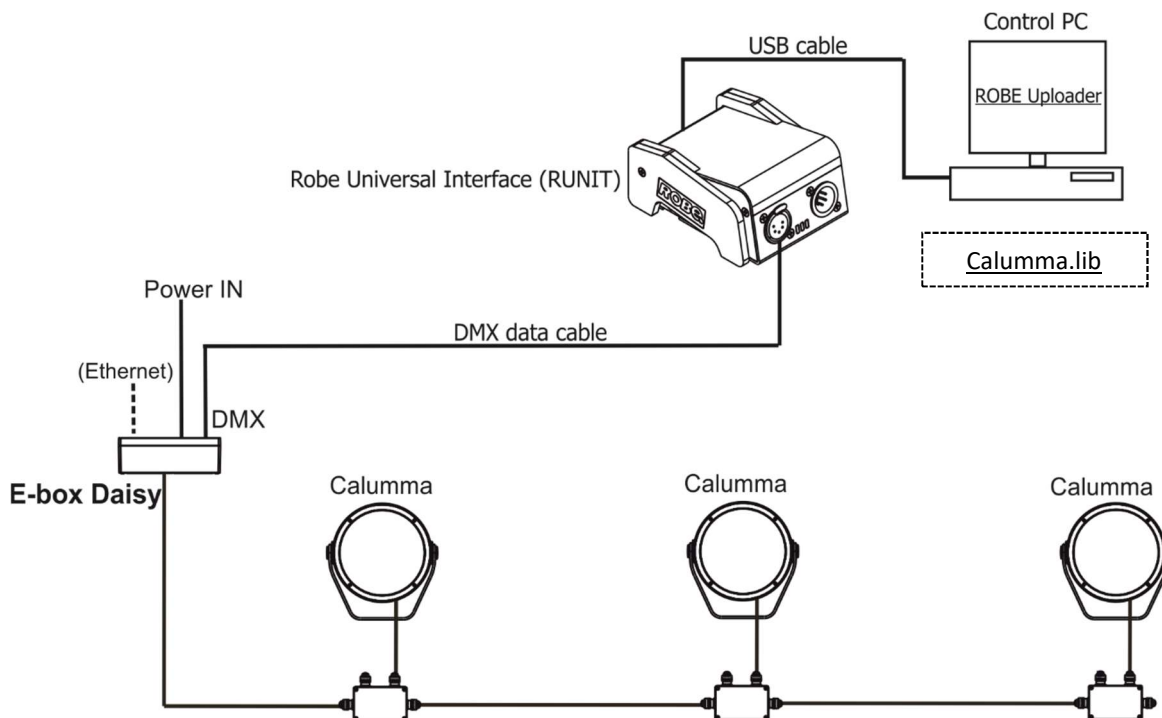

If you use a connection via junction boxes and you need to update connected E-box, switch the E-box to the Standard mode and use the EminereEbox.lib in the ROBE Uploader to update E-box. After updating the E-box, switch it back to the Pass-Trough mode.

Calumma XL

DMX connection

For updating of Calumma modules, use the file Calumma.lib in the ROBE uploader.

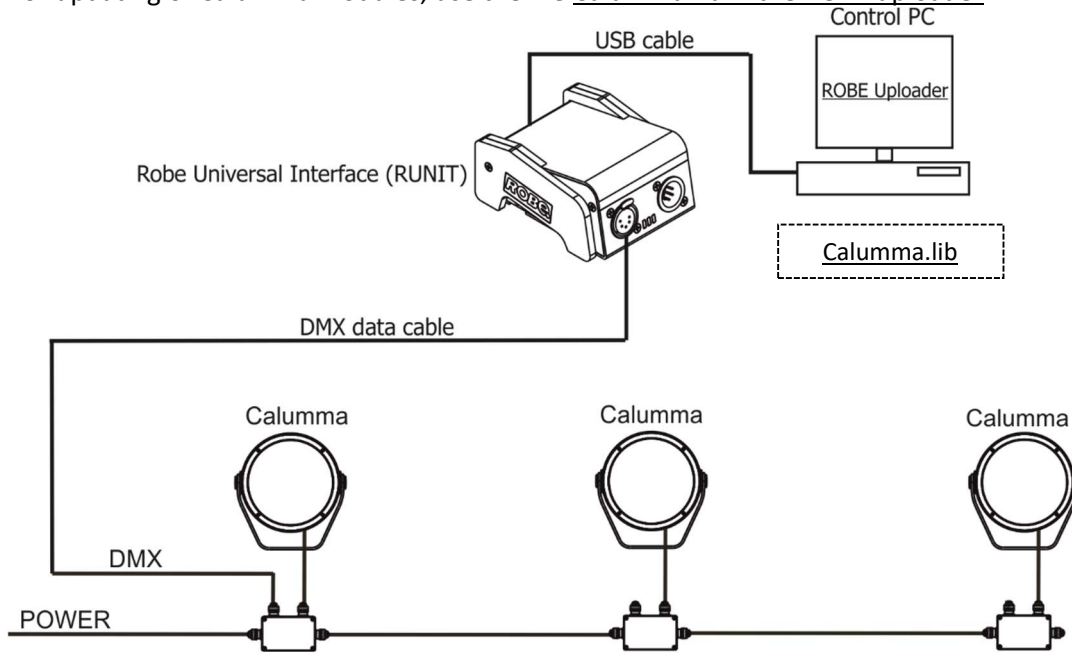

6. Technical specifications

Power supply

- Electronic auto-ranging
- Input voltage: 120 - 277V AC, 50/60 Hz
- Power consumption:
 - Calumma XL MC: 175 W
 - Calumma XL SC: 185 W
- Inrush current:
 - Calumma XL MC: 60A(twidth= 510us measured at 50% Ipeak) at 230VAC, cold start
 - Calumma XL SC: 60A(twidth= 510us measured at 50% Ipeak) at 230VAC, cold start

Optic

- Light source:
 - Calumma XL MC: 19 x high power multichip LEDs
 - Calumma XL SC: 121 x high power single chip LEDs
- Colour variants: RGBW (W - 6500 K), RGBA, PW (W - 3000 K)
- Beam Angle Calumma XL MC:
 - Symmetrical: 9°, 15°, 25°, 30°, 45°, 65°, 100°
 - Bi-symmetrical: 10° x 30°, 30° x 10°, 10° x 60°, 60° x 10°, 15° x 45°, 45° x 15°, 15°x90°, 90°x15°, 30°x60°, 60°x30°, 30°x90°, 90°x30°
- Beam Angle Calumma XL SC:
 - Symmetrical: 10°, 15°, 25°, 30°, 45°, 65°, 100°
 - Bi-symmetrical: 10° x 30°, 30° x 10°, 10° x 60°, 60° x 10°, 15° x 45°, 45° x 15°, 15°x90°, 90°x15°, 30°x60°, 60°x30°, 30°x90°, 90°x30°
 - Asymmetrical side, Asymmetrical forward
- Projected Lumen Maintenance: L90B10 >90.000 hrs, Ta = 25°C / 77°F

Compatible drivers

- E-box Daisy
 - 1 Output
 - 1 Main power Input
 - Control: DMX, Art-Net, sACN , W-DMX control, RDM
 - Pixel control
 - 120-277V Input
 - Connection via terminal blocks, inlets via grommet
 - IP67
- E-box Star
 - 6 outputs
 - 1 Main power Input
 - Control: DMX, Art-Net, sACN , W-DMX control, RDM
 - Pixel control
 - 120-277V Input
 - Connection via terminal blocks, inlets via grommet
 - IP67
- E-box Lite
 - 1 output
 - 1 Main power Input
 - Control: DMX, W-DMX control, RDM
 - Pixel control

Calumma XL

120-277V Input

Connection via screw terminal blocks, inlets via grommet

IP67

Wireless DMX/RDM module RW 001 (only wireless version of the fixture)

- Supported protocols: full RDM support, CRMX , W-DMX™ G2, G3,G4 and G4S
- Operational frequency range: 2402-2480 MHz
- Output power: 100 mW
- Receiver sensitivity (0.1% BER): -93 dBm
- Crystal Clock Frequency : 16.0 MHz
- Contains FCC ID: 2A6PL-DMXRDMRW001
- Contains IC: 29573-DMXRDMRW001

Mounting method

- Via yoke
- Adjustability: -180°/+180°

Housing

- High pressure die-cast aluminium body
- Tempered glass

Cooling system

- Convection

Total heat dissipation

- Calumma XL MC: 448 BTU/h (calculated)
- Calumma CL SC: 473 BTU/h (calculated)

Protection factor

- CE: IP 67 (IP 66 junction box)
- US: Suitable for wet location

Impact rating

- IK10

Operating ambient temperature range

- -20°C /+40°C (-4°F /+104°F)

Connection - CE

- DMX connection
Calumma IN: Flamar 3x AWG 16 + 1 x (2x AWG 24) Standard 1m with bare-end (P/N 1305 1508)
Interconnecting cables: Flamar 3x AWG 16 + 1 x (2x AWG 24) (P/N 1305 1508)
Junction box
- Wireless DMX connection
Calumma IN: Flamar 3x AWG 16 + 1 x (2x AWG 24) Standard 1m with bare-end (P/N 1305 1508)
Junction box
- Wireless to DMX connection
Calumma IN: Flamar 3x AWG 16 + 1 x (2x AWG 24), Standard 1m with bare-end (P/N 1305 1508)
Interconnecting cables: Flamar 3x AWG 16 + 1 x (2x AWG 24) (P/N 1305 1508)
Junction box

Calumma XL

- DALI connection
Calumma IN: 4BD51501-3core+DALI 5X1.5mm2 Hybrid LSZH black, standard 1m with bare-end (P/N 13053693)
Interconnecting cables: 4BD51501-3core+DALI 5X1.5mm2 Hybrid LSZH black (P/N 1305 3693)
Junction box (P/N 1098 0714)
- DMX or Ethernet via E-box and Junction box
Calumma IN: Flamar 3x AWG 16 + 1x (2x AWG 24), standard 1m with bare-end (P/N 1305 1508)
Interconnecting cables: Flamar 3x AWG 16 + 1 x (2x AWG 24), (P/N 1305 1508)
Junction box
- DMX or Ethernet via E-box and IN/OUT cables
Calumma IN: Leader cable MM (P/N 13053493) with hybrid connector, standard 0.5 m
Calumma OUT: Leader cable MF (P/N 13053494) with hybrid connector, standard 0.5 m
Leader cables: Leader Cable FF 2 m (P/N 13053438)
Leader Cable FF 5 m (P/N 13053440)
Leader Cable FF 10 m (P/N 13053436)
Leader Cable FF 25 m (P/N 13053437)
Jumper cables: Jumper Cable FF/FM 0,25 m (P/N1 3053422)
Jumper Cable FF/FM 0,5 m (P/N 13053423)
Jumper Cable FF/FM 1 m (P/N 13053425)
Jumper Cable FF/FM 2 m (P/N 13053427)
Jumper Cable FF/FM 3 m (P/N 13053428)
Jumper Cable FF/FM 5 m (P/N 13053430)
Jumper Cable FF/FM 10 m (P/N 13053424)
- Power On/Off connection
Calumma IN: H07BB-F 3G1.5, standard 1m with bare-end (P/N 13051443)
Junction box (P/N 1098 0714)

Connection - US

- Wireless DMX connection
Calumma IN: SJTW 6x 14AWG, standard 1m with bare-end, (P/N 1305 3480)
Junction box
- Wireless to DMX connection
Calumma IN: SJTW 6x 14AWG, standard 1m with bare-end, (P/N 1305 3480)
Interconnecting cables: SJTW 6x 14AWG (P/N 1305 3480)
Junction box
- DALI connection
Calumma IN: SJTW 5x 14AWG, standard 1m with bare-end (P/N 1305 3336)
Interconnecting cables: SJTW 5x 14AWG (P/N 1305 3336)
Junction box
- DMX or Ethernet via E-box and Junction box
Calumma IN: SJTW 6x 14AWG ,standard 1m with bare-end (P/N 1305 3480)
Interconnecting cables: SJTW 6x 14AWG ,(P/N 1305 3480)
Junction box
- Power On/Off connection
Calumma IN: SEOOW power 3x16AWG, standard 1m with bare-end (P/N 13051558-1)
Junction box (P/N 1098 0714)

Calumma XL

Weight

- Calumma XL SC 12.7 kg (28 lbs)
- Calumma XL MC 12.3 kg (27.12 lbs)

Dimensions (All dimensions in mm [inch])

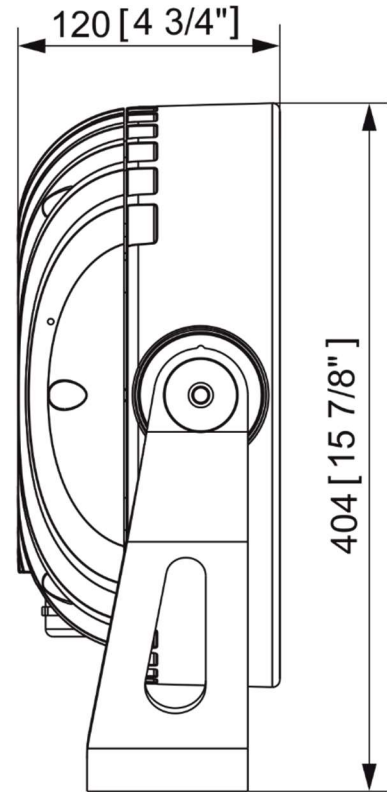
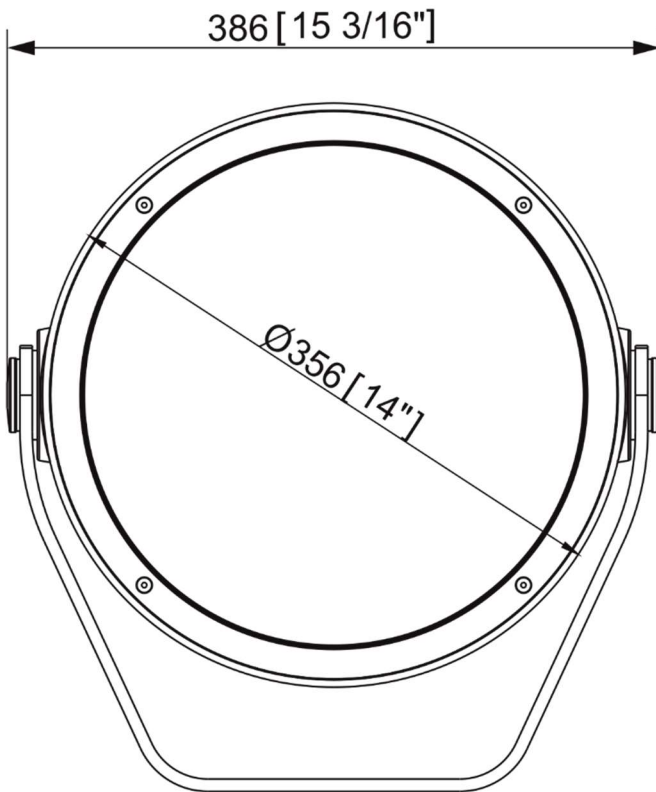

Calumma XL

Calumma XL with Pole clamp adaptor

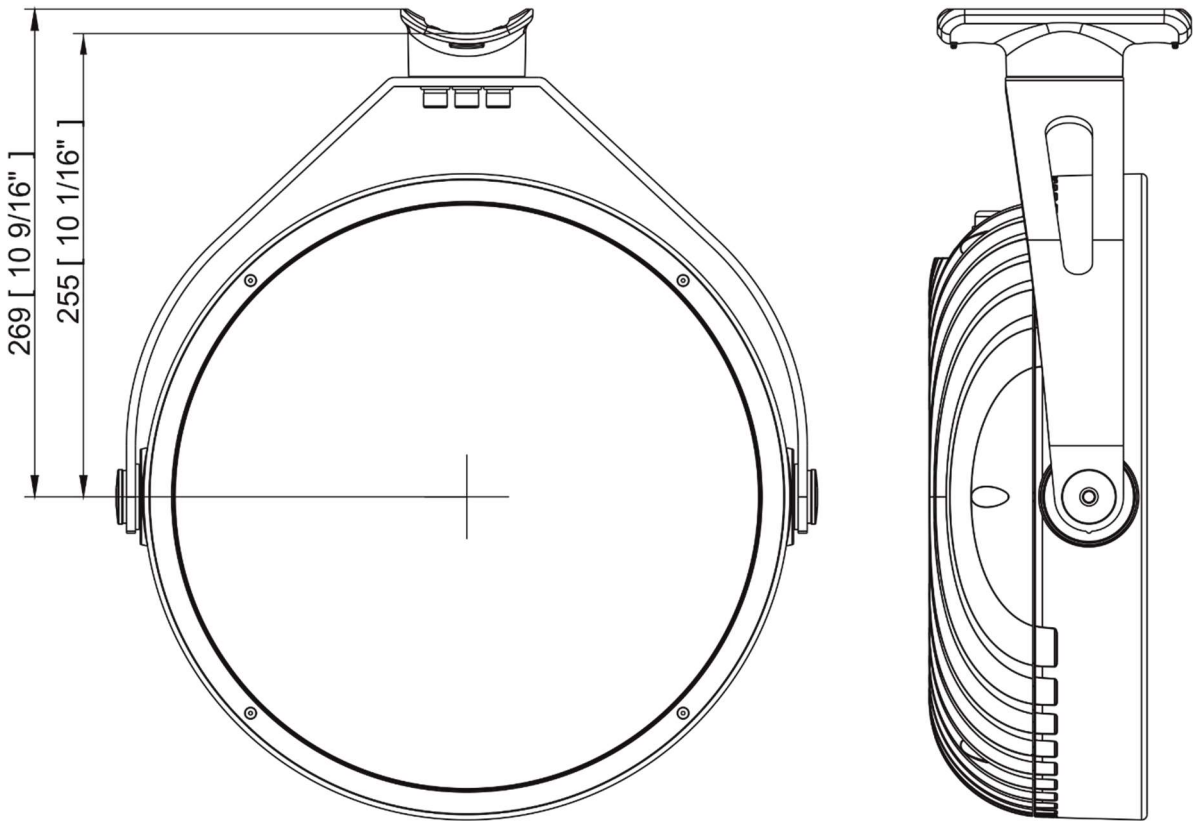

Calumma XL with Outdoor Foil Holder

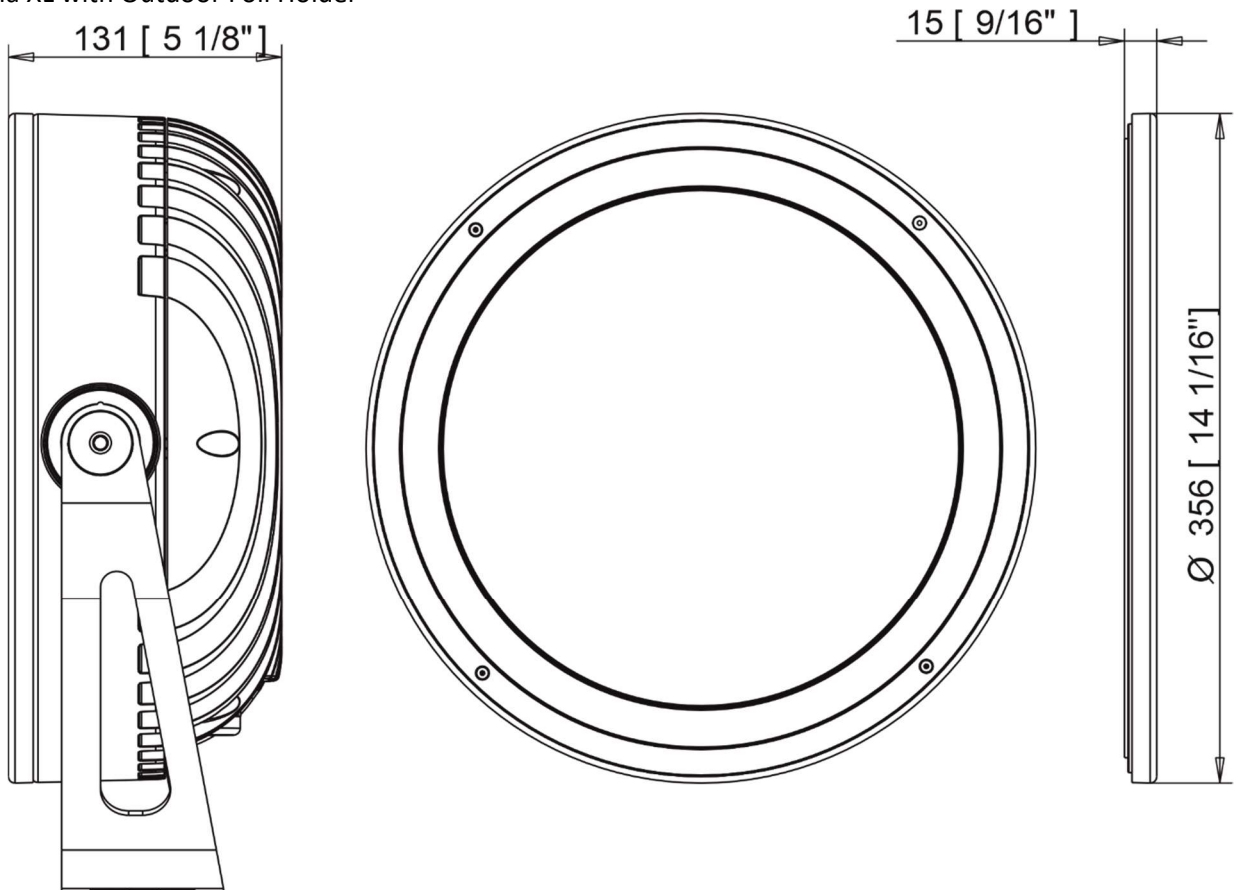

Calumma XL

Junction box

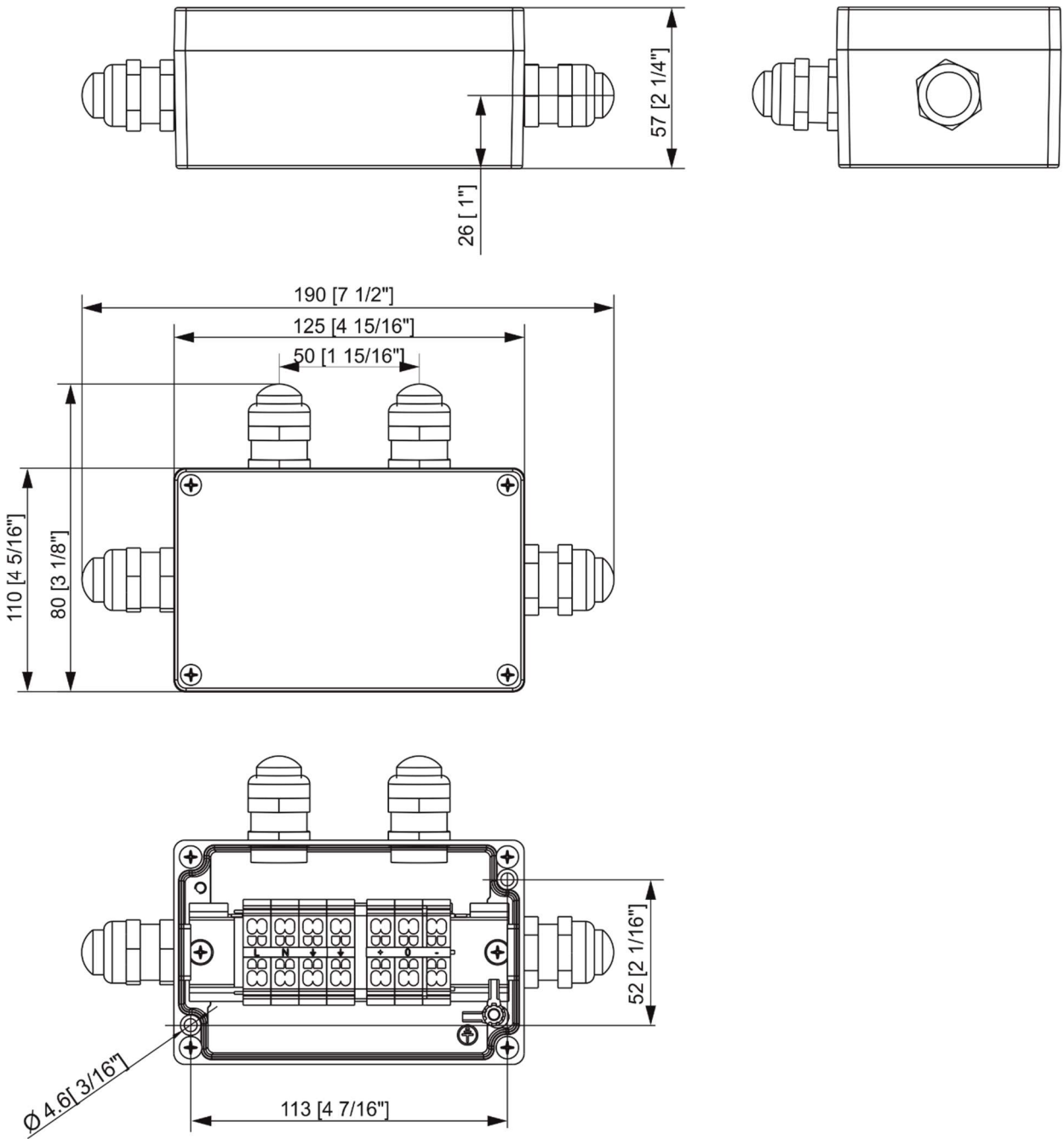

Calumma XL

Booster box

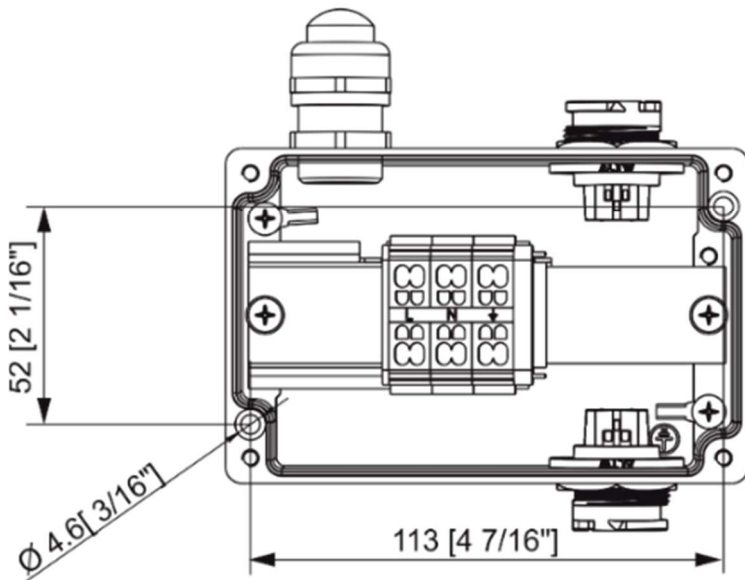
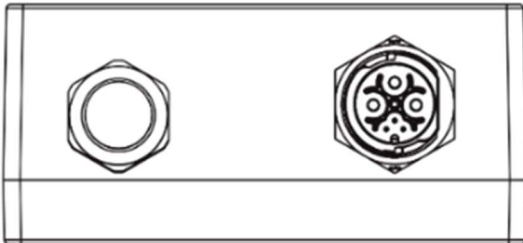
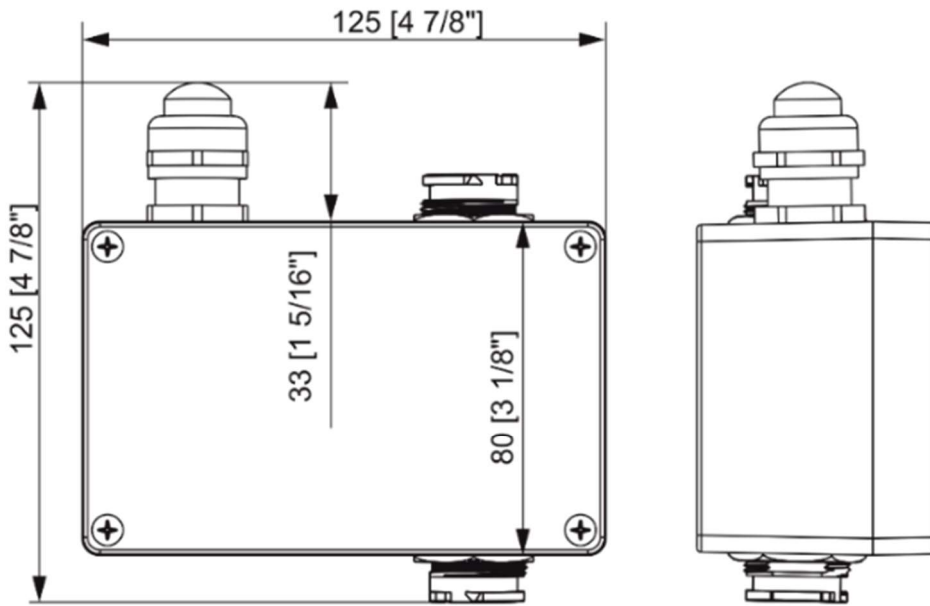
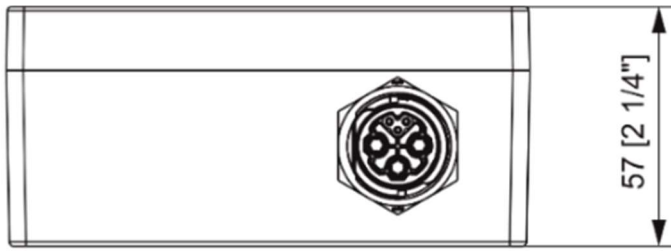

Calumma XL

Pole clamp adaptor for Calumma

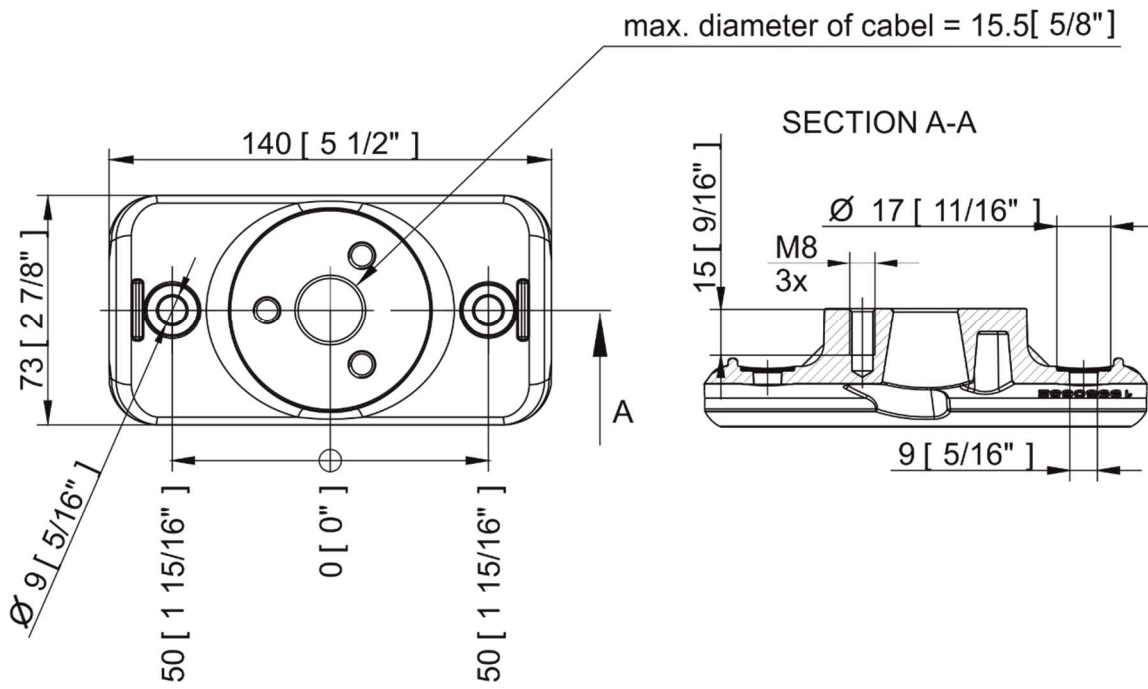
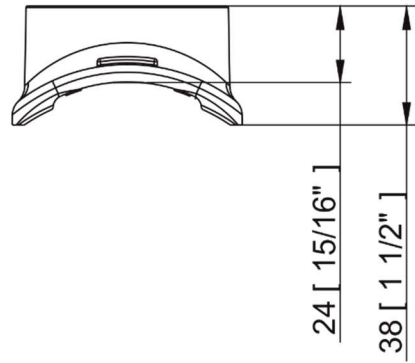
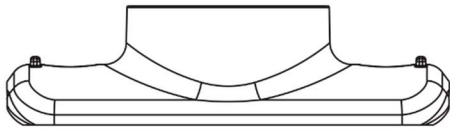

Calumma XL

Land Spike

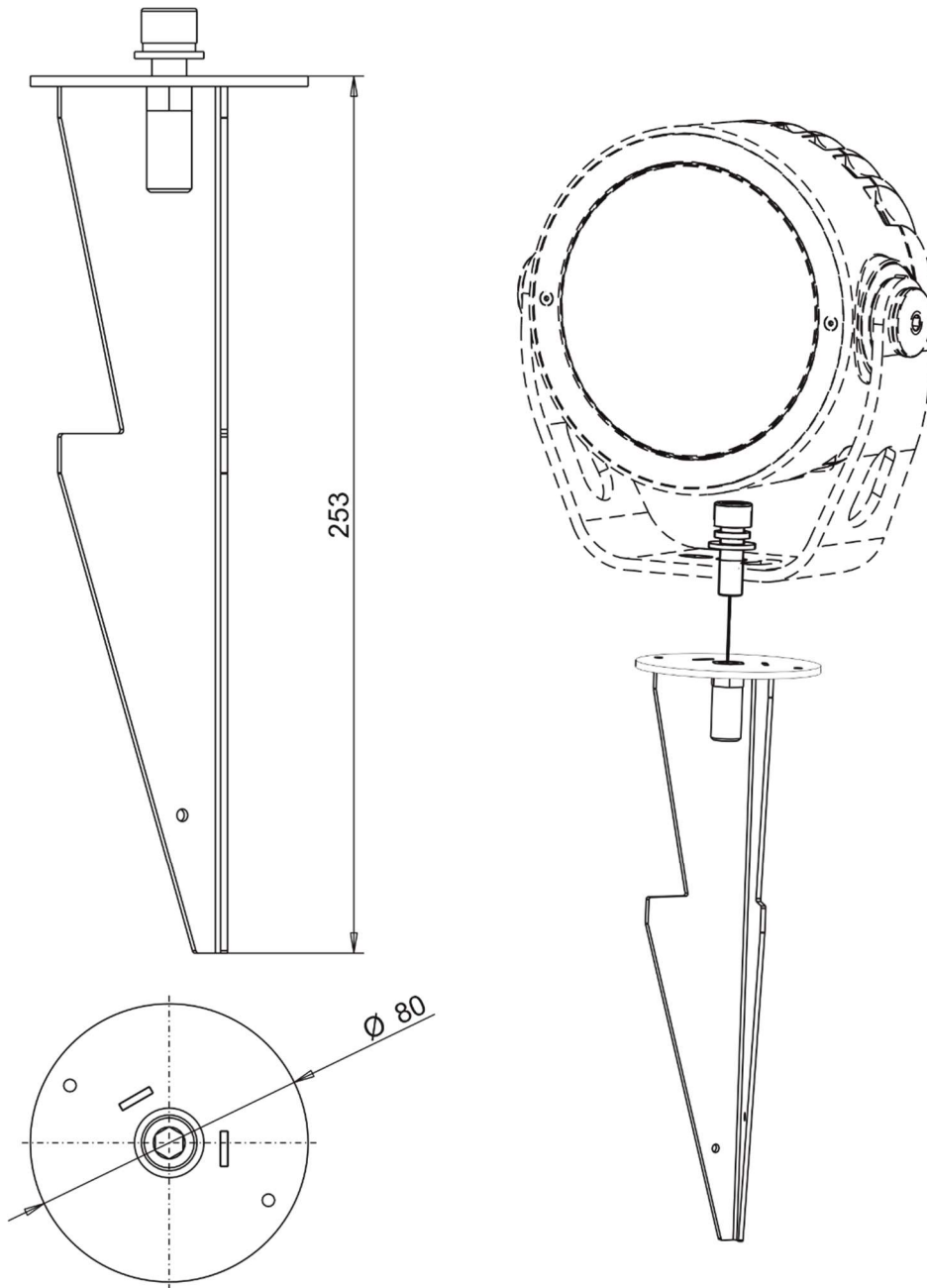

Included items

- 1 x Calumma XL MC / Calumma XL SC
- 1 x User manual

Optional accessories

Junction Box for Calumma, 1x Output, Ral 9006 (P/N 10980757)

Junction Box for Calumma, 1x Output, Ral 9011 (P/N 10980714)

Top Hat Calumma XL RAL9011 (P/N 10980735)

Half Top Hat Calumma XL RAL9011 (P/N 10980739)

Pole clamp adaptor for Calumma RAL 9011 (P/N 10980783)

Tenon Adaptor for Calumma XL

Pole Mount Bracket for Calumma XL

Land Spike for Calumma S, M, L, XL (P/N 10981065)

E-box Daisy (P/N 10063655)

E-box Daisy/W (P/N 10063638)

E-box Lite (P/N 10063657)

E-box Lite/W (P/N 10063653)

E-box Star (P/N 10063656)

E-box Star/W (P/N 10063644)

Booster box (P/N 10063712)

7. Cleaning and maintenance

DANGER !

Disconnect from the mains before starting any maintenance or cleaning work

Rinse off loose dirt with low pressure water spray. Wash the housing with a soft brush or sponge and a mild, non-abrasive washing detergent. Rinse it.

Maintenance and service operations are only to be carried out by a qualified person.

Should you need any spare parts, please use ROBE OEM parts.

7.1 Disposing of the product

To preserve the environment please dispose or recycle this product at the end of its life according to the local regulations and codes.

8. ChangeLog

This section summarizes changes in the user manual.

Version of manual	Date of issue	Description of changes
1.1	13/10/2022	DMX protocol ver. 1.1 added
1.2	09/01/2023	Software update description changed
1.3	10/02/2023	DMX protocol ver. 1.2 added
1.4	17/02/2023	Pole adaptor for Calumma added
1.5	22/02/2023	Power ON/Off connection description changed
1.6	06/03/2023	Number of connected Calummas changed
1.7	17/04/2023	Termination of DMX line specified
1.8	03/07/2023	On/Off version more specified
1.9	20/09/2023	New cabel for DALI connection (CE version)
2.0	23/01/2024	Control panel of RDM manager added, DMX chart ver. 1.3
2.1	14/06/2024	Land Spike added to optional accessories
2.2	26/09/2024	Outdoor Foil Holder for Calumma added

Specifications are subject to change without notice.

September 26, 2024

Copyright © 2022-2024 Robe Lighting - All rights reserved

Made in CZECH REPUBLIC by ROBE LIGHTING s.r.o. Palackeho 416/20 CZ 75701 Valasske Mezirici

DMX protocol for Calumma - All sizes - MC and SC

Version: 1.3 (16 modes in total)

Mode/Channels in all								Mode 1- RGBW(A)-8bit, Mode 2- RGB 8-bit, Mode 3- full RGBW(A)	
1	2	3	4	5	6	7	8-10	Mode 4- White-full control, Mode 5- Reduced RGBW(A)	
4	3	12	3	6	8	15	Reserved	Mode 6- Reduced RGBW(A)+white control, Mode 7- Full control	
								Mode 7-Full RGBW(A)+virt. Colour wheel	
								RGBW/RGBA/RGB modes	
Mode/channels							DMX Value	Function	Type of control
1	2	3	4	5	6	7			
-	-	-	-	-	-	1		Special functions	
							0	No function <i>To activate following functions , stop in DMX value for at least 3 sec.</i>	step
							1-2	Save current DMX values to fixture as initial DMX values.	step
							3-4	Show saved initial DMX values	step
							5-6	Run factory demo sequences at switching fixture on (without DMX)	step
							7-8	Insect friendly light On (RGBA version only)	step
							9-10	Insect friendly light Off (RGBA version only)	step
							11-255	Reserved	
1	1	1	-	1	1	2		Red	
							0 - 255	Red LEDs saturation control (0-100%)	proportional
-	-	2	-	-	-	3		Red Fine	
							0 - 255	Red LEDs saturation control fine	proportional
2	2	3	-	2	2	4		Green	
							0 - 255	Green LEDs saturation control (0-100%)	proportional
-	-	4	-	-	-	5		Green Fine	
							0 - 255	Green LEDs saturation control fine	proportional
3	3	5	-	3	3	6		Blue	
							0 - 255	Blue LEDs saturation control (0-100%)	proportional
-	-	6	-	-	-	7		Blue Fine	
							0 - 255	Blue LEDs saturation control fine	proportional
4	-	7	-	4	4	8		White (Amber)	
							0 - 255	White LEDs saturation control (0-100%)	proportional
-	-	8	-	-	-	9		White (Amber) Fine	
							0 - 255	White LEDs saturation control fine	proportional
-	-	9	1	-	5	10		Green correction	
							0	Uncorrected white	step
							1-127	Minus green - uncorrected white	proportional
							128	Uncorrected white (128=default)	step
							129-255	Uncorrected white - Plus green	proportional
-	-	10	2	-	6	11		Colour temperature correction (CTC)	
							0	No function	step
							1 - 10	Tungsten dimming 2700 K	step
							11 - 20	Tungsten dimming 3200 K	step
							21-255	Colour temperature changing from 1800 K --> 6500 K (21-1800K, 66-2700K, 91-3200K,141-4200K, 211-5600K, 255-6500K)	proportional
-	-	-	-	-	-	12		Virtual Colour Wheel	
							0	No function	step

DMX protocol

Mode/channels							DMX Value	Function	Type of control
1	2	3	4	5	6	7			
							1-2	White 1800 K	step
							3-4	White 2700 K	step
							5-6	White 3200 K	step
							7-8	White 4200 K	step
							9-10	White 5600 K	step
							11-12	White 6500 K	step
							13	Blue (Blue=full, Red+Green+White/Amber=0)	step
							14-23	Red=0, Green->up,Blue =full, White/Amber=0	proportional
							24	Cyan (Red=0, Green=full, Blue =full, White/Amber=0)	step
							25-34	Red=0, Green=full, Blue->down, White/Amber=0	proportional
							35	Green (Red=0, Green=full, Blue =0, White/Amber=0)	step
							36-45	Red->up, Green=full, Blue=0, White/Amber=0	proportional
							46	Yellow (Red=full, Green=full, Blue=0, White/Amber=0)	step
							47-56	Red=full, Green->down, Blue=0, White/Amber=0	proportional
							57	Red(Red=full, Green=0, Blue=0, White/Amber=0)	step
							58-67	Red=full, Green=0, Blue->up, White/Amber=0	proportional
							68	Magenta (Red=full, Green=0, Blue=full, White/Amber=0)	step
							69-78	Red -> down, Green=0, Blue=full, White/Amber=0	proportional
							79	Blue (Red=0, Green=0, Blue=full, White/Amber=0)	step
								Transition effects	
							80-87	Rainbow effect (with fade time) from slow-> fast	proportional
							88-95	Rainbow effect (without fade time) from slow-> fast	proportional
							96-103	Full dynamic white (1800K->6500K->1800K) (with fade time) from slow-> fast	proportional
							104-111	Full dynamic white (1800K->6500K->1800K) (without fade time) from slow-> fast	proportional
							112-119	Dynamic warm white (1800K-3000K-1800K) (with fade time) from slow-> fast	proportional
							120-127	Dynamic warm white (1800K-3000K-1800K) (without fade time) from slow-> fast	proportional
							128-135	Rainbow effect + full dynamic white (with fade time) from slow-> fast	proportional
							136-143	Rainbow effect + full dynamic white (without fade time) from slow-> fast	proportional
							144-151	Blue/Green effect (with fade time) from slow-> fast	proportional
							152-159	Blue/Green effect (without fade time) from slow-> fast	proportional
							160-167	Red/Blue effect (with fade time) from slow-> fast	proportional
							168-175	Red/Blue effect (without fade time) from slow-> fast	proportional
							176-183	Green/Red effect (with fade time) from slow-> fast	proportional
							184-191	Green/Red effect (without fade time) from slow-> fast	proportional
							192-199	Blue/4000K effect (with fade time) from slow-> fast	proportional
							200-207	Blue/4000K effect (without fade time) from slow-> fast	proportional
							208-215	Green/4000K effect (with fade time) from slow-> fast	proportional
							216-223	Green/4000K effect (without fade time) from slow-> fast	proportional
							224-231	Red/4000K effect (with fade time) from slow-> fast	proportional
							232-239	Red/4000K effect (without fade time) from slow-> fast	proportional
						13		Shutter/Strobe	
							0-31	Shutter closed	step
							32-63	Shutter open	step
							64-95	Strobe-effect from slow to fast	proportional

DMX protocol

Mode/channels							DMX Value	Function	Type of control
1	2	3	4	5	6	7			
							96-127	Shutter open	step
							128-143	Opening pulse in sequences from slow to fast	proportional
							144-159	Closing pulse in sequences from fast to slow	proportional
							160-191	Shutter open	step
							192-223	Random strobe-effect from slow to fast	proportional
							224-255	Shutter open	step
-	-	11	3	5	7	14		Dimmer	
							0 - 255	Light intensity coarse (0-100%)	proportional
-	-	12	-	6	8	15		Dimmer Fine	
							0 - 255	Light intensity fine	proportional
Copyright © 2022-2024 Robe Lighting s.r.o. - All rights reserved									
All Specifications subject to change without notice									

DMX protocol for Calumma - All sizes - MC and SC					
Version: 1.3 (16 modes in total)					
Mode/Channels in all				TW Modes: Mode 11- White selection + Dimmer, Mode 12- WW + CW	
11	12	13	14-16	PW Mode: Mode 13- Dimmer	
3	4	2	Reserved		
TW and PW modes					
Mode/channels			DMX Value	Function	Type of control
11	12	13			
1	-	-		White colour selection	
			0 - 255	White from 2700 K - 6500 K	proportional
-	1	-		Warm White	
			0 - 255	Warm White LEDs saturation control (0-100%)	proportional
-	2	-		Cool White	
			0 - 255	Cool White LEDs saturation control (0-100%)	proportional
2	3	1		Dimmer	
			0 - 255	Light intensity coarse (0 - 100%)	proportional
3	4	2		Dimmer Fine	
			0 - 255	Light intensity fine	proportional
Copyright © 2022-2024 Robe Lighting s.r.o. - All rights reserved					
All Specifications subject to change without notice					