

Lyrae M SC Lyrae M MC

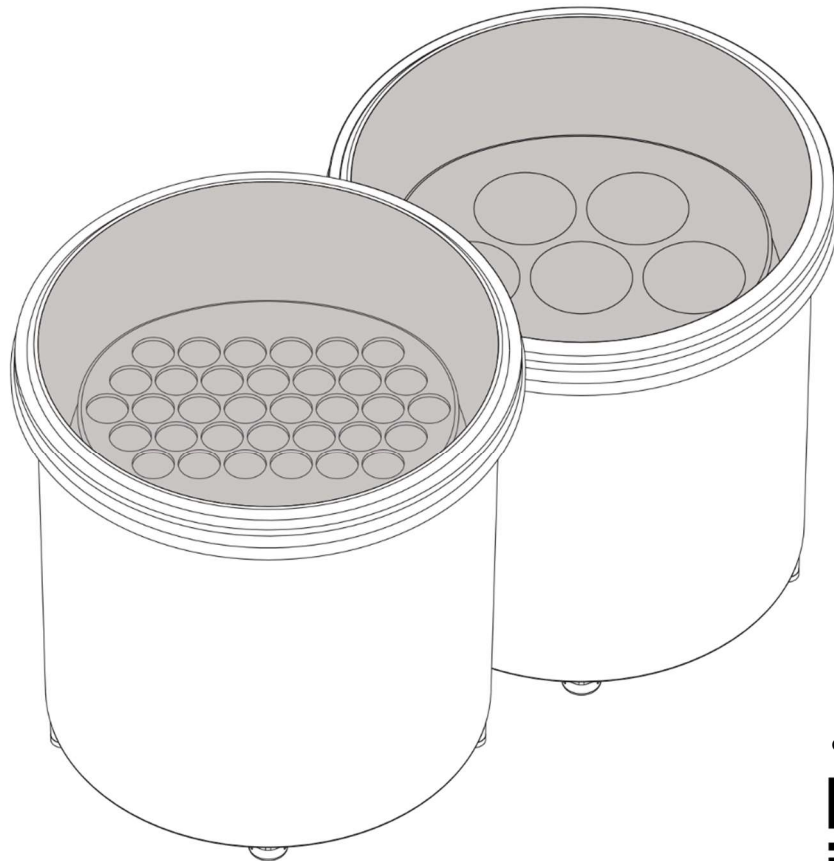

OR code for user manual



USER MANUAL

Version 1.1

Table of contents

1. Safety instructions	3
2. Fixture exterior view	5
3. Installation	5
4. Control and connection options	14
4.1 DMX	14
4.2 DALI	15
4.3 DMX or Ethernet via E-box	16
4.4. Example of Control panel in RDM manager	17
4.5. Tilt setting	20
5. Software update	22
6. Technical specifications	24
7. Cleaning and maintenance	30
7.1 Disposing of the product	30
8. ChangeLog	30

**FOR YOUR OWN SAFETY, PLEASE READ THIS USER MANUAL CAREFULLY
BEFORE POWERING OR INSTALLING YOUR LYRAE M!
Save it for future reference.**

This device has left our premises in absolutely perfect condition. In order to maintain this condition and to ensure safe operation, it is absolutely necessary for the user to follow the safety instructions and warnings written in this manual.

The manufacturer will not accept liability for any resulting damages caused by the non-observance of this manual or any unauthorized modification to the device.

Unauthorized modification will void warranty.

1. Safety instructions

DANGEROUS VOLTAGE CONSTITUTING A RISK OF ELECTRIC SHOCK IS PRESENT WITHIN THIS UNIT!

Always disconnect the fixture from AC power before cleaning, servicing or installing.

Make sure the supply/data cable cord is not damaged by sharp edges.

Do not install the fixture near an open flame.

Refer servicing to qualified service personnel.

This fixture falls under protection class I. Therefore this fixture has to be connected to a mains socket outlet with a protective earthing connection.

Do not connect this fixture to a dimmer pack.

LED light emission. Risk of eye injury. Do not look into the beam from a short distance without suitable protective eyewear. Do not look at LEDs with magnifiers or similar optical instruments that may concentrate the light output.

Avoid brute force when installing or operating the fixture.

The fixture was designed for outdoor use. This fixture must not be used for underwater installation.

When choosing the installation spot, please make sure that the fixture is not exposed to extreme heat or dust.

Avoid using the unit in locations subject to possible impacts.

The fixture body never must be covered with cloth or other materials when the fixture is under operation.

Only operate the fixture after having checked that the housing is firmly closed and all screws are tightly fastened.

The fixture becomes hot during operation. Allow the fixture to cool approximately 30 minutes prior to servicing or maintenance.

Dismantling of the unit in case of its repair must not be carried out in rain or snowfall.

Please consider that unauthorized modifications on the fixture are forbidden due to safety reasons!

If this device will be operated in any way different to the one described in this manual, the product may suffer damages and the warranty becomes void. Furthermore, any other operation may lead to dangers like short-circuit, burns, electric shock etc.

The product (covers and cables) must not be exposed to a high frequency electromagnetic field higher than 3V/m.

Immunity of the equipment is designed according to the standard EN 55035 Electromagnetic compatibility of multimedia equipment - Immunity requirements.

Emission of the equipment complies with the standard EN55032 Electromagnetic compatibility of multimedia equipment – Emission Requirements according to class B.

This equipment has been tested and found to comply with the limits for a Class B digital device, pursuant to part 15 of the FCC Rules. These limits are designed to provide reasonable protection against harmful interference in a residential installation. This equipment generates, uses and can radiate radio frequency energy and, if not installed and used in accordance with the instructions, may cause harmful interference to radio communications. However, there is no guarantee that interference will not occur in a particular installation. If this equipment does cause harmful interference to radio or television reception, which can be determined by turning the equipment off and on, the user is encouraged to try to correct the interference by one or more of the following measures:

- Reorient or relocate the receiving antenna.
- Increase the separation between the equipment and receiver.
- Connect the equipment into an outlet on a circuit different from that to which the receiver is connected.
- Consult the dealer or an experienced radio/TV technician for help.

2. Fixture exterior view

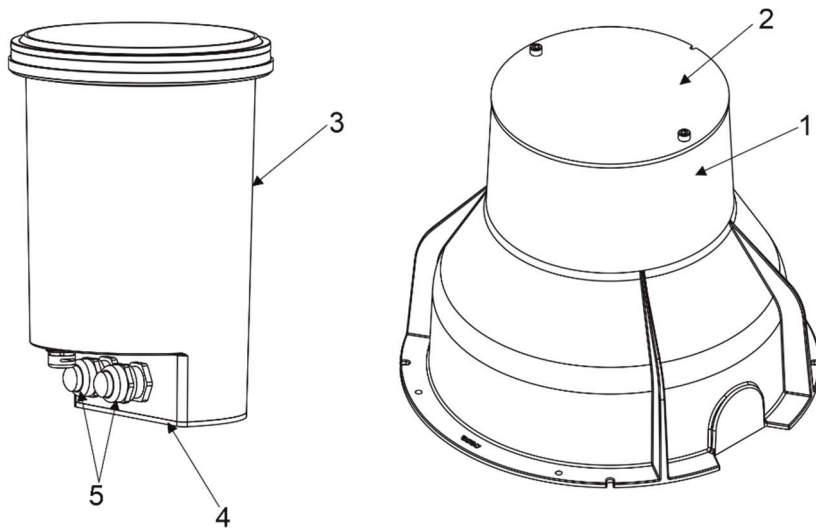

1. Mounting sleeve
2. Temporary cover
3. Lyrae
4. Junction box
5. 2 x cable gland M20x1.5

3. Installation

The unit must be installed by a qualified electrician in accordance with all national and local electrical and construction codes and regulations.

This device falls under class one and must be grounded!

With respect to the purpose of using the unit, the residual current circuit breaker is highly recommended.

Warning!

If the Lyrae M will be exposed to max. allowed static load, the subsoil under the installation sleeve has to withstand load of: 45kN (standard covering glass)

23kN (antiskid covering glass).

Prepare a mounting hole with a good drainage - minimum depth of the gravel drainage has to be 300mm. There must not stay water in the mounting sleeve (1). If the mounting sleeve will be placed to the concrete hole, suitable draining pipe must be installed on the bottom of the hole.

Prepare supply cables in protection conduit for supply of the Lyrae.

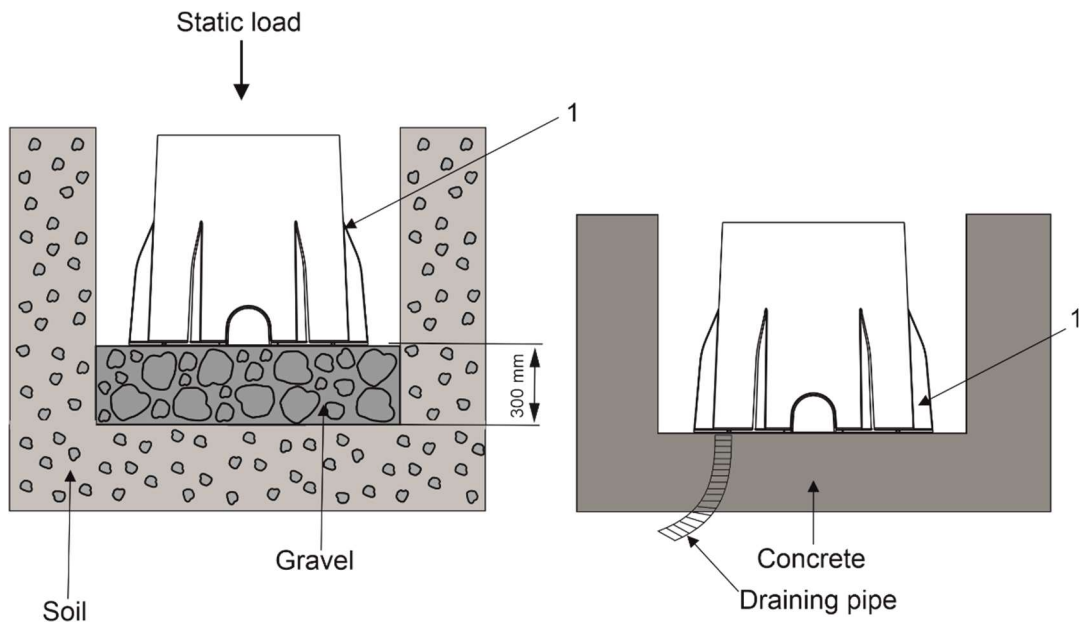

1. Prepare holes (6) on each side of the mounting sleeve according to the size of the protection conduit.

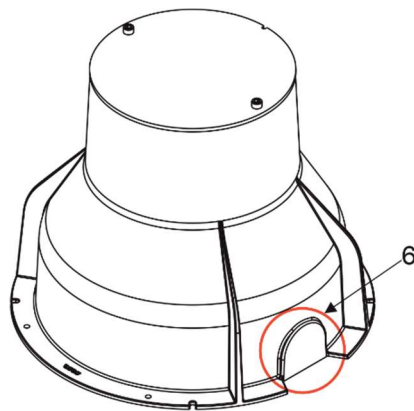

2. Insert the mounting sleeve into the mounting hole and level it using a spirit level (7).

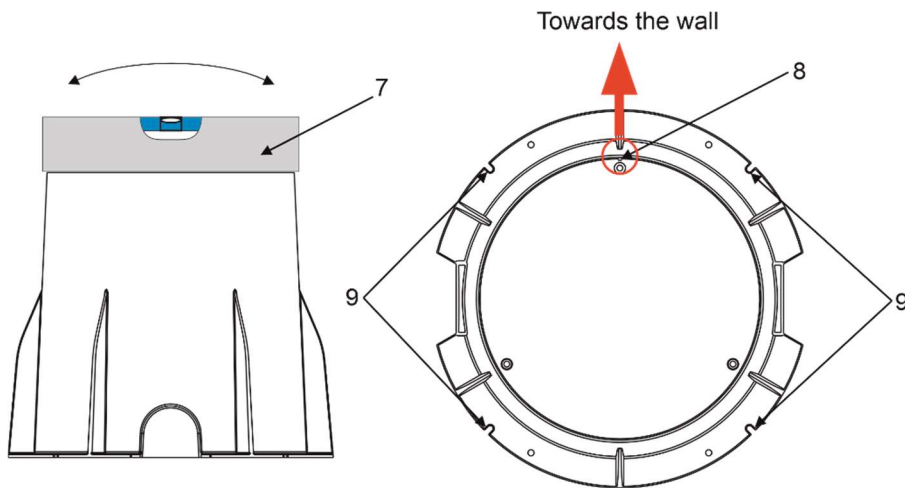

Lyrae M

The position mark (8) on the mounting sleeve and the temporary cover serves for orientation of the mounting sleeve and should be oriented to the wall for correct direction of the light beam tilting. The position mark (8) also serves for orientation at placing the Lyrae M to the mounting sleeve. The beam can be tilted towards the teeth (16) in the housing of the Lyrae M.

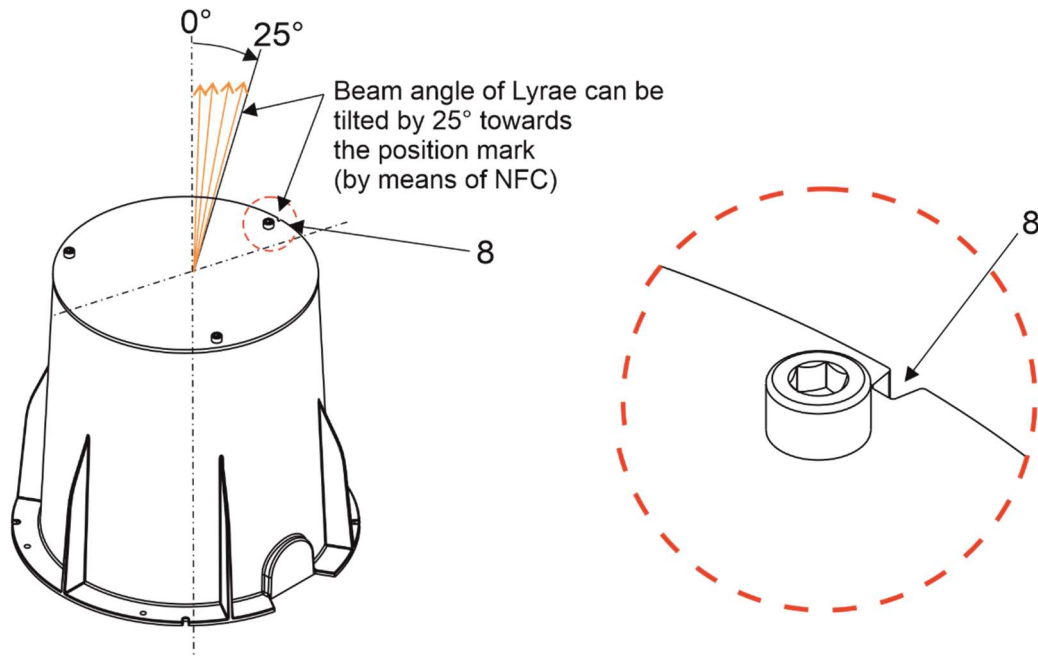

Detail of the Lyrae M inserted in the mounting sleeve – top view (without temporary cover):

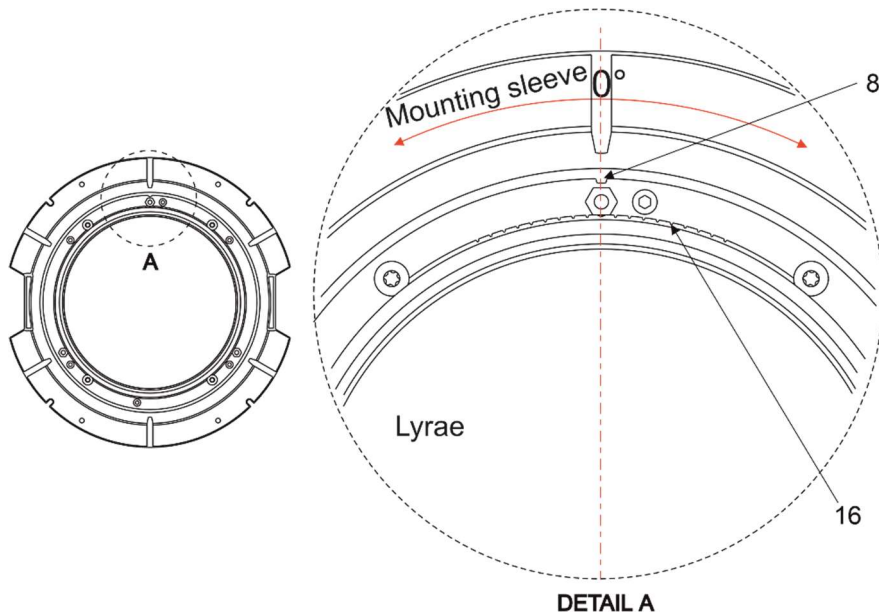

3. Fasten the mounting sleeve to the bottom of the mounting hole by means of four apertures (9) with diameter of 5.3 mm. Use fasteners suitable for your mounting surface.

Lyrae M

4. Unscrew three screws (10) and remove the temporary cover (2) from mounting sleeve.

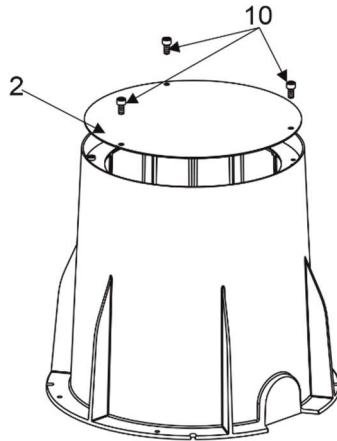

5. Pull the cables (12) through the protection conduit (11) into the mounting sleeve. The recommended cable length is 500mm above the level of the mounting sleeve. The supply/data cables must be placed in a protective conduit (11).

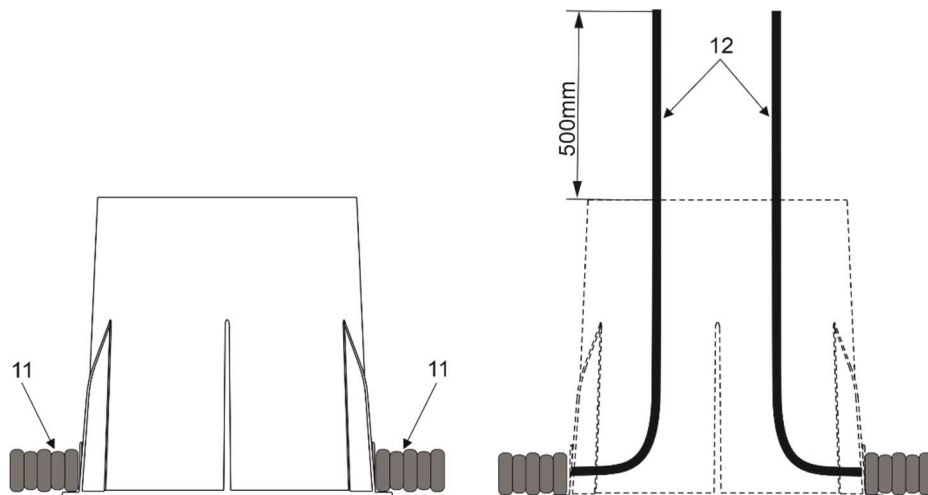

6. Fold cables (12) to the mounting sleeve and screw the temporary cover (2) back on the mounting sleeve with three screws (10).

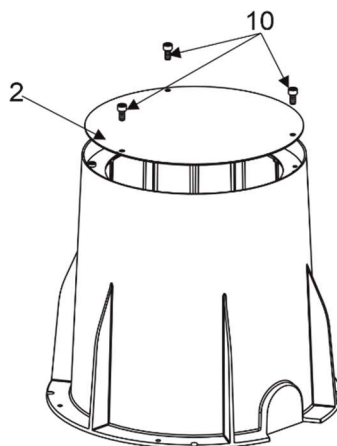

Lyrae M

- The mounting hole can be filled up with soil, gravel or concrete. Filling material should be in the same level with the top of the mounting sleeve (for Bevel Edge Trim) or in the same level with top of mounting sleeve cover (for Flush Trim).

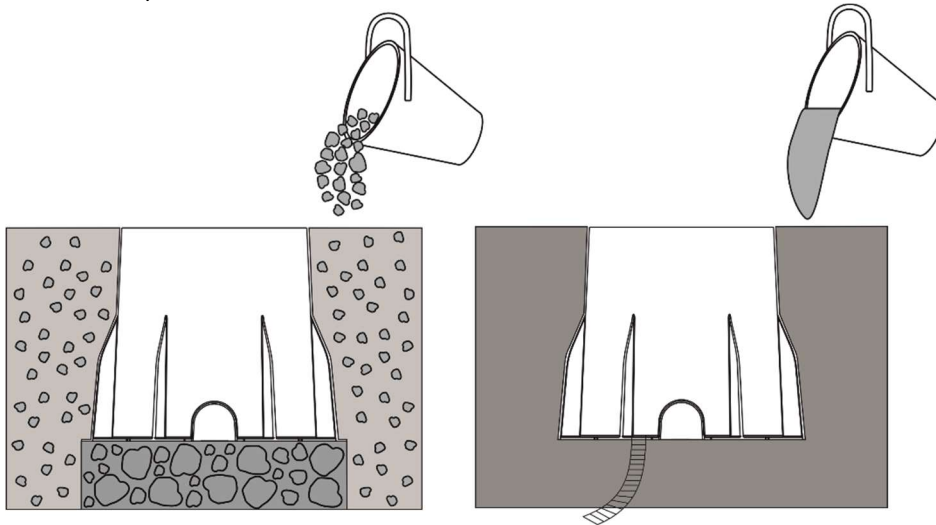

Note: the Lyrae M can be installed with the Bevel Edge Trim or the Flush Trim. Every trim version has its temporary cover for the mounting sleeve:

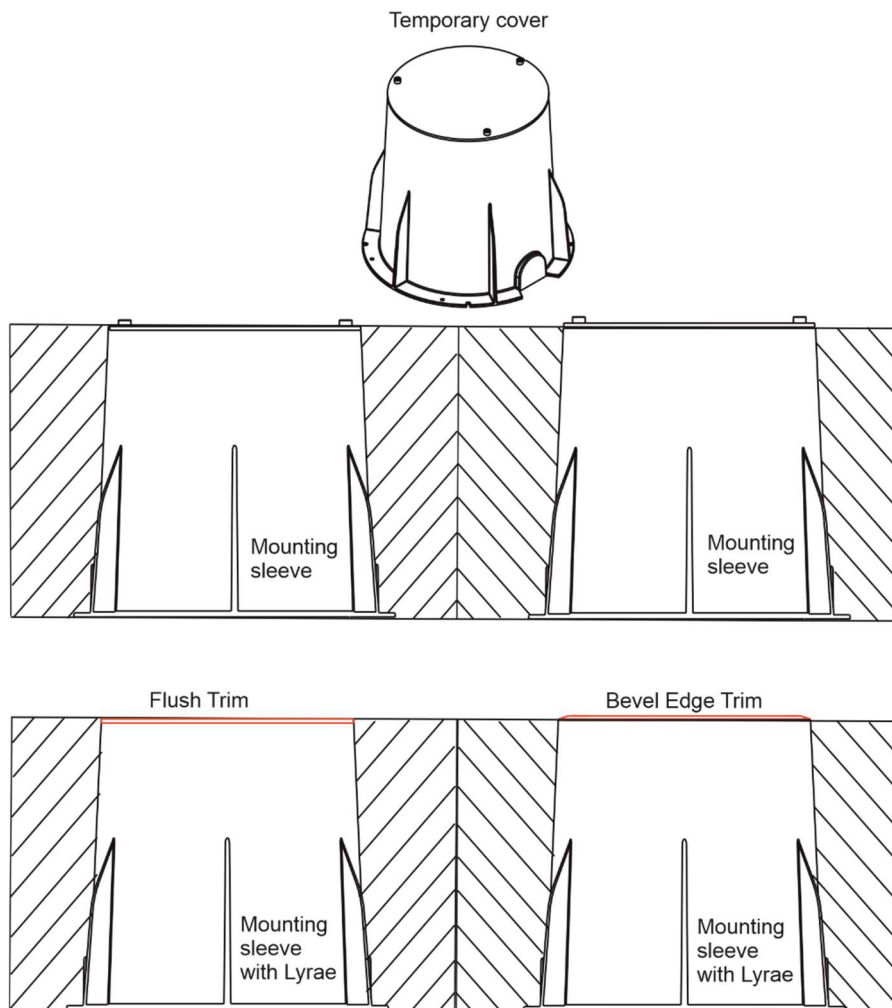

- Remove the temporary cover (2) of the mounting sleeve and pull cables out of the mounting sleeve.

9. The Lyrae is equipped with auto-switching power supply that automatically adjusts to any 50-60Hz AC power source from 120-277 Volts.
 Remove the cover of the junction box (13) by unscrewing 6 screws (14). Remove end caps from cable glands before passing cables.
 Pass the cables through the cable glands M20x1.5 (16) and connect them to the terminal block (15). Do not assemble the gland yet. Use a wrench size 22 for the cable gland M20x1.5
 Remove end caps from cable glands before passing cables.
 Two cable glands M20 with standard seals serve for cable of diameter of 6-12mm, for smaller diameter of cable (4-8mm) you have to remove original sealing from the cable gland M20 and use the enclosed reducing seal instead of it. Reducing seal (P/N 13051388) for diameter of cable 4-8mm is enclosed.
 Fully tighten cable gland nuts and check that cables are properly fastened in the cable glands.
Note: To keep declared IP rating, unused cable gland has to be covered with the end cap.

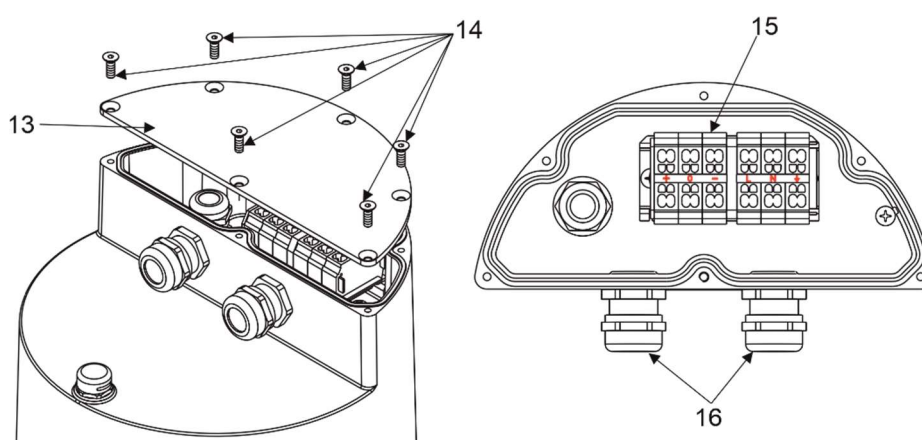

Wiring of the Junction box

Terminal block	Function	Terminal block	Function
L	Live	+	Data +
N	Neutral	-	Data -
⊕	Ground (earth)	0	Data ground (0V)



NOTE: DMX line of Lyraes M has to be terminated at last fixture. Connect a 120 Ohm resistor between terminals + and - in the junction box at last fixture.

Example:

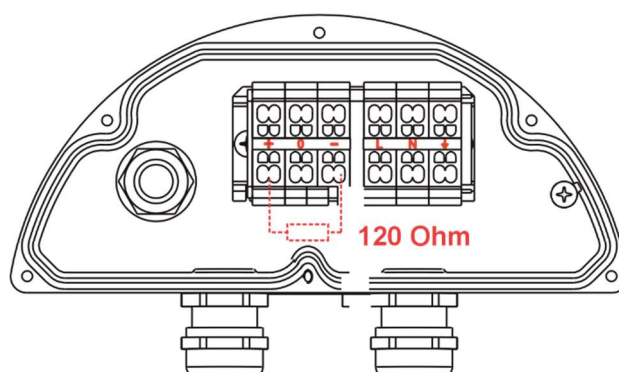



OR terminate via RDM Set the 'Manufacturer PID' 'Terminator active' to '1' at last fixture by means of RDM Control Panel.



Ensure **ONLY** the last fixture in the line is terminated using **ONE** of the above methods!

We recommend to apply an adequate layer of the paste LOCTITE 5331 on the plastic holder of the cable gland before inserting it into the body of the gland and an adequate layer of the paste LOCTITE 577 on the thread of the gland body in case that you need to unscrew and remove the cable gland from the housing of the junction box and and screw it back to the housing.

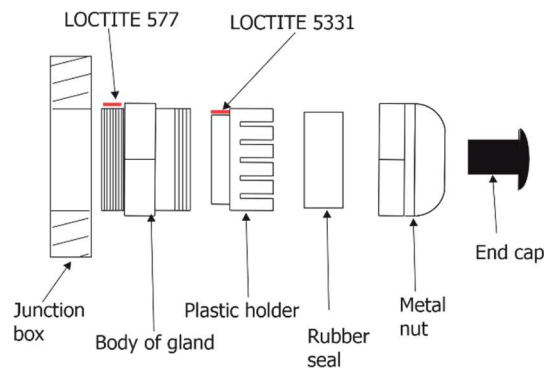

Failure to properly install cable glands will result in failure of the watertight seal!

- 10.** After checking all connections in terminal block (15), fill the junction box with synthetic resin. Make sure the end cap is inserted in any unused cable glands, and the ground wire for the cover is pulled from the junction box before filling it with resin. Read and follow all instructions stated on the resin bag prior to filling the junction box. The junction box has to be fully filled by resin. Connect the ground wire to the cover (13) of the junction box and screw the cover to the junction box by means of three screws (14). Use a tightening torque of 3Nm for all screws. **Fastening of the cover must be done before hardening the resin.**

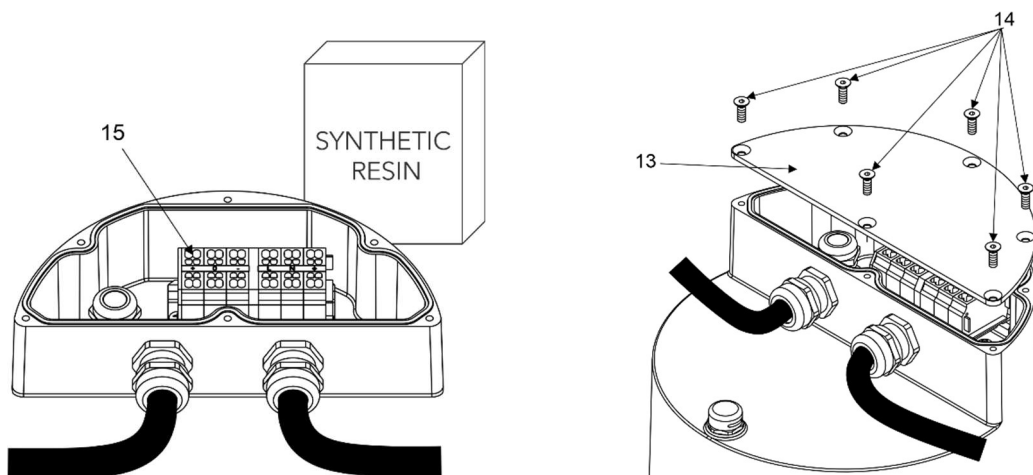

Lyrae M

11. Unscrew three screws (10) and remove the temporary cover (2) from mounting sleeve and insert the Lyrae M with cables (3) to the mounting sleeve (1).

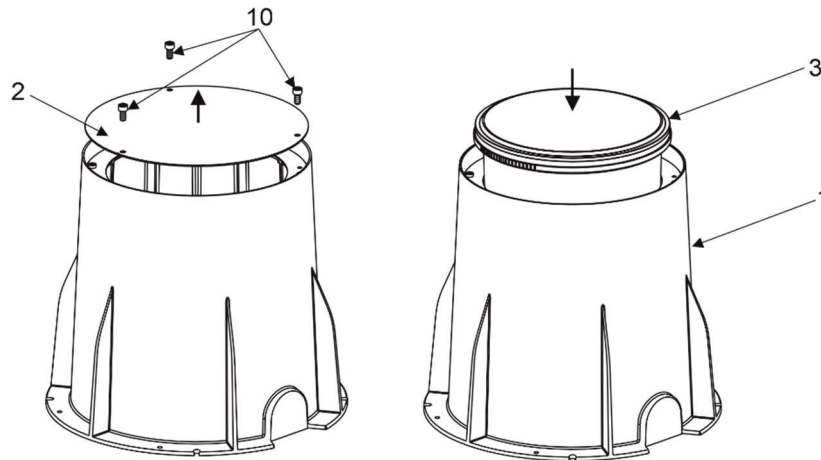

Teeth (16) in the housing of Lyrae M allows you fine positioning of the Lyrae M against the position mark (8) in the mounting sleeve.

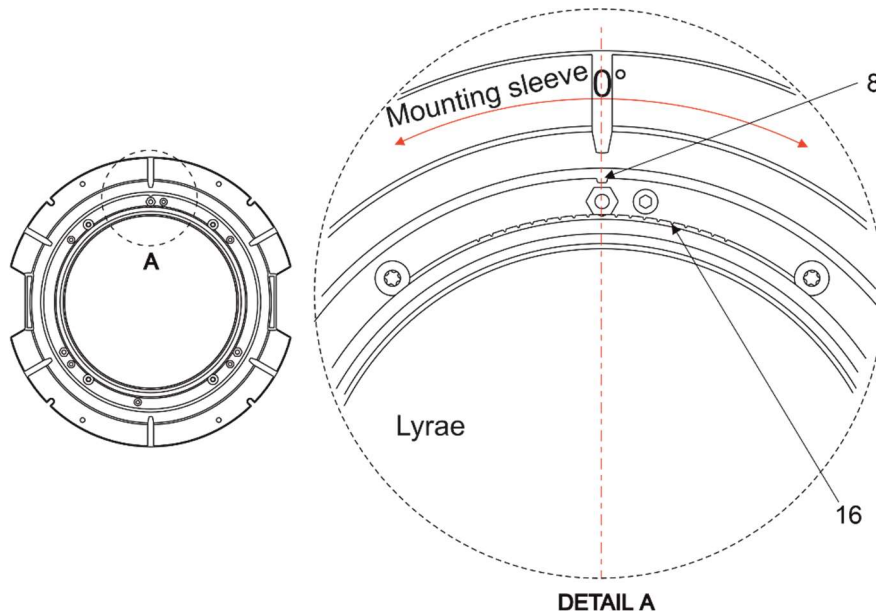

Lyrae M

- 12.** Fasten the Lyrae M to the mounting sleeve by means of the four Allen screws M6x20 (17).
Place the trim (19) on the Lyrae M and fasten it by means of three flat Allen screws M6x35 (20).

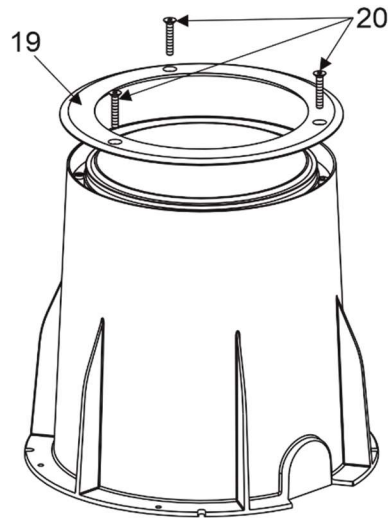
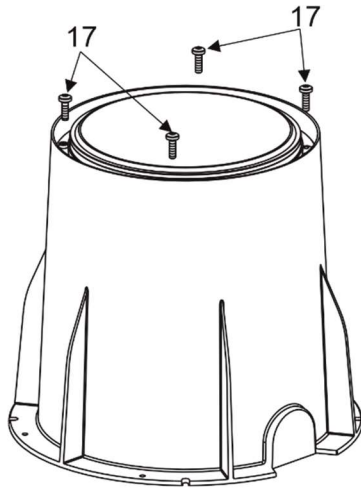

4. Control and connection options

4.1 DMX

Example:

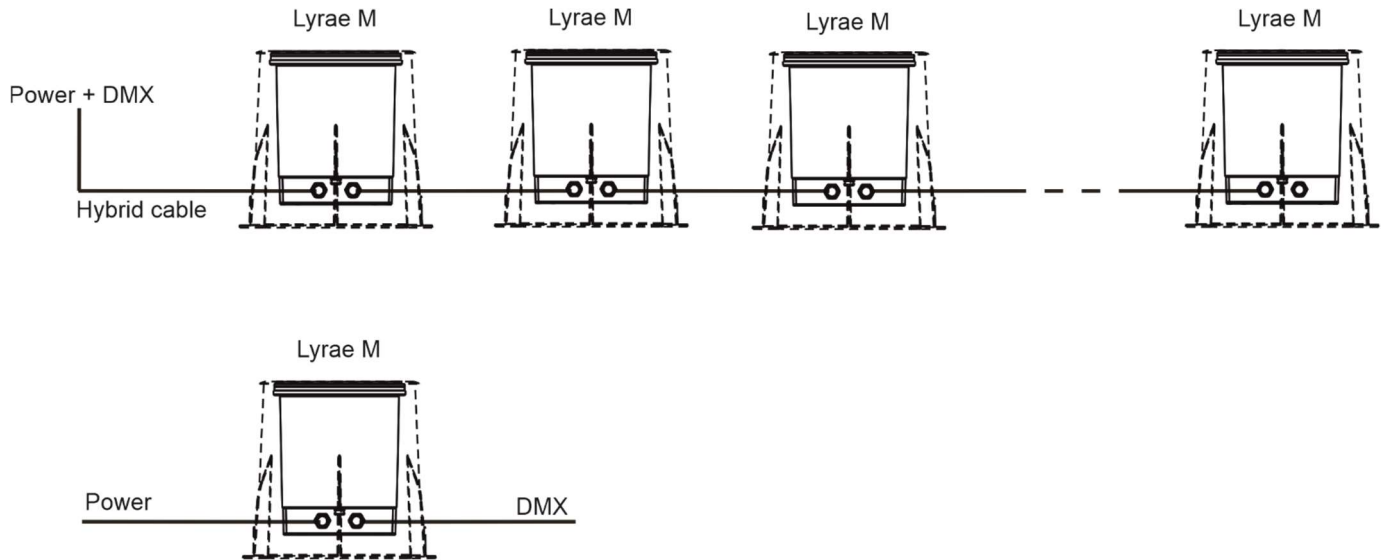

Up to 32 Lyraes M can be connected in DMX chain.

Wiring of the Junction box

CE

Core	Power connection	Core	DATA connection
Black	L	Red	Data +
Blue	N	White	Data -
Yellow/Green	⊕ (earth)	Shielding	Data ground (0V)

Colours of wires apply to the 5-cored cable Li9YC11Y 3xAWG16+1x(2xAVG24 Shielded and Jacketed) (P/N 3051508)



NOTE: DMX line of Lyraes M has to be terminated at the last fixture as stated in the chapter 3. Installation.

4.2 DALI

Example:

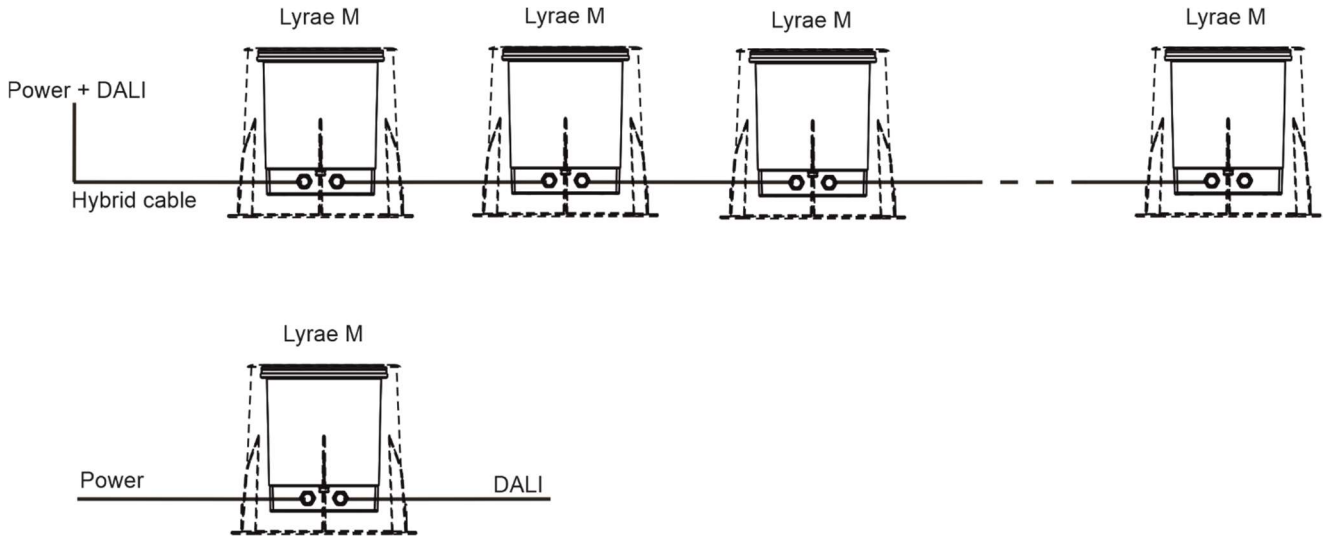

Up to 64 Calummas can be connected in DALI network.

Wiring of the Junction box

CE.

Core	Power connection	Core	DATA connection
Black	Live (L)	Red	Data
White	Neutral (N)	Orange	Data
Yellow/Green	GND ⊕	-	-

Colours of wires apply to the 5-cored cable Belcom B2ca DALI 5X1.5mm² Hybrid LSZH black (P/N 1305 3693).

US.

Core	Power connection	Core	DATA connection
Black	Live (L)	Red	Data
White	Neutral (N)	Orange	Data
Yellow/Green	GND ⊕	-	-

Colours of wires apply to the 5-cored cable SJTW 5x 14AWG, black (P/N 13053336).

4.3 DMX or Ethernet via E-box

The E-box menu allows you to switch connected Lyraes M to the two modes (Personality →E-box mode):

Standard - LED modules are switched to an internal serial connection. DMX addressing of connected LED modules is made automatically (default DMX address = 1, changes can be done by the E-box menu or by RDM).

Pass-Thr - (Pass through). LED modules are switched to an internal parallel connection. DMX addressing of connected LED modules has to be done manually by means of the Robe Universal Interface and the software RDM Manager.

Max. 32 fixtures can be connected to one LED output of the E-Box (Star, Daisy, Lite) in this mode.



NOTE: DMX Data line of Lyraes at each LED output of the E-box has to be terminated at the last fixture as stated in the chapter 3 Installation.

Example of connection for E-box Daisy.

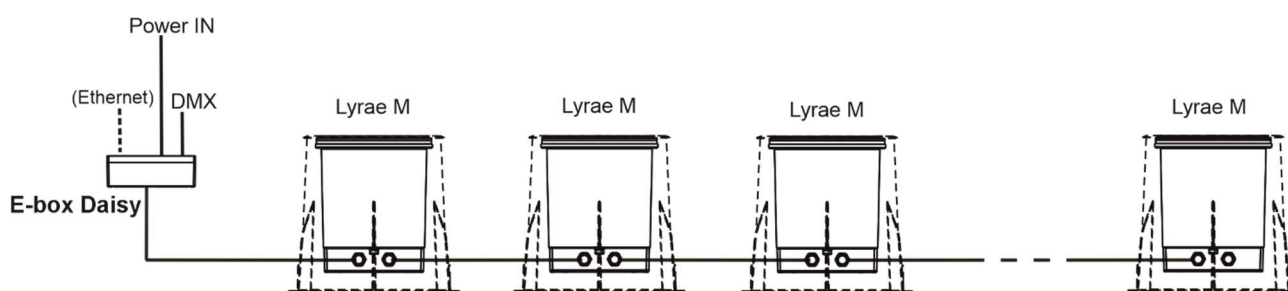

Wiring of the Junction box.

CE

Core	Power Connection	Core	DATA Connection
Brown	L	Purple	Data +
Blue	N	Orange	Data -
Yellow/Green	⊕ (earth)	Shielding	Data ground (0V)

Colours of wires apply to the 5-cored cable WCA-2.0x3C+(0.2x1P+D+AL)+MY(05) (P/N 13053138).

US

Core	Power Connection	Core	DATA Connection
Black	L	Red	Data +
White	N	Orange	Data -
Green	⊕ (earth)	Shielding	Data ground (0V)

Colours of wires apply to the 5-cored cable WCA-14#x3C+(24#x1P+D+AL)(03) (P/N 13053139).

Lyrae M

Number of connected Lyraes M to one E-box output depends on a cable length, power voltage and E-box operation mode.

The tables below state max. theoretical number of Lyraes M connected to the one LED output of the E-box.

Standard mode of E-box.

Lyrae M SC Lyrae M MC	Voltage			
	120V	190V	230V	277V
Cable length *				
10 m	28	44	53	64
20 m	28	44	53	64
30 m	19	44	53	64
50 m	12	29	43	62
70 m	8	21	31	44
100 m	6	15	21	31
200 m	3	7	11	16

Pass-Through mode of E-box

Lyrae M SC Lyrae M MC	Voltage			
	120V	190V	230V	277V
Cable length *				
10 m	28	32	32	32
20 m	28	32	32	32
30 m	19	32	32	32
50 m	12	29	32	32
70 m	8	21	31	32
100 m	6	15	21	31

* Cable length is a total cable length between power supply (e.g. E-box) and last connected Lyrae M.

Example: Total cable length=L1+L2+L3

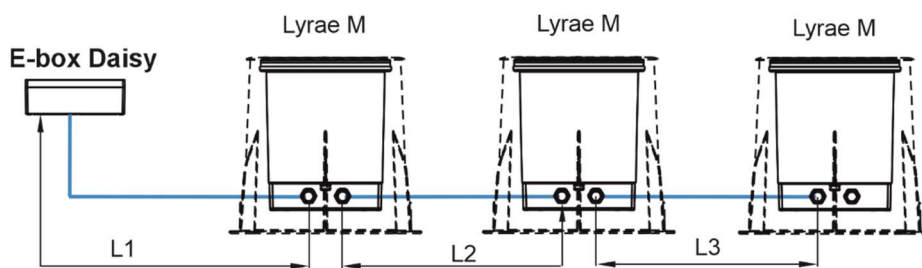

Notice for the E-box Star: The tables above state max. total number of Lyraes M connected to 6 LED outputs of the E-box Star (or max. number of Lyraes M connected to one output if the rest of outputs is not connected).

4.4. Example of Control panel in RDM manager

The software RDM manager is available on the ROBE website (<https://www.robe.cz/support>), product RUNIT WTX.

Lyrae M

Control panel

Device: 52:53-01:2e:00:7f 

Product information

RDM protocol version: 0x0100

Device model ID: 0x012e

Product category: 0x0102

Software version: 23

Subdevice count: 0

Sensor count: 2

Manufacturer label: ROBE lighting s.r.o.

Device model description: Lyrae

Device label:

DMX512 setup

DMX512 footprint: 4

Current personality:

Personalities count: 16

DMX address:

Power/Lamp setup

Device hours: 3728

Configuration

Factory defaults:

Control

Identify device:

Display settings

Manufacturer PIDs

LED calibration 4byte HEX! (RGBW/RGBA): (hex)

Insect friendly light (0 = off, 1 = on): (hex)

WiFi unlink (1-unl): (hex)

Terminator active (0-dis 1-en): (hex)

Green arrow  saves changes made in the Control panel to the Lyrae.

Manufacturer PIDs

Lyrae M

LED calibration 4byte HEX! (RGBW/RGBA) - the item shows 4 bytes of calibration values for calibrated white colours of RGBW(RGBA) Lyrae.

E.g.



CTC channel has to be set to some calibrated white colour (21 DMX-1800K, 66 DMX-2700K, 91 DMX-3200K, 141 DMX-4200K, 211 DMX-5600K, 255 DMX-6500K) otherwise the item shows values "ff ff ff ff" (and calibration values cannot be saved to the Lyrae).

Warning!

Changing and saving values in this item will affect calibrated white colour(s) of the Lyrae M .

Insect friendly light - the item effects RGBA Lyrae M only. If the item is on, blue colour is not used in calibrated white colours. This modification of white lights results in a smaller attraction of white light for insects (mosquitos, moths..). The function is also available from DMX chart (channel Special Function, range 7-10 DMX).

Wireless unlink - the item is inactive for Lyrae M.

Terminator active - the item allows you to terminate line of Lyraes M at last Lyrae M.

4.5. Tilt setting

You can tilt light beam of the Lyrae M by means of the mobile application ROBE COM or by DMX.

Mobile application.

Download and install the application ROBE COM from Google Play (for Android 5.0 and higher) or App Store (for iOS 12.0 and higher) to your mobile phone. Your mobile phone has to support NFC (Near-Field Communication).

After installing the ROBE COM, run the application by touching the icon . The following screen will appear:

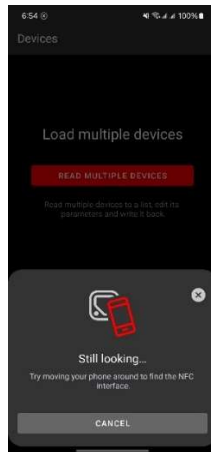

Hold the mobile phone close to the NFC point on the glass cover of the Lyrae M which is marked with the symbol NFC (the Lyrae M has to be connected to power).

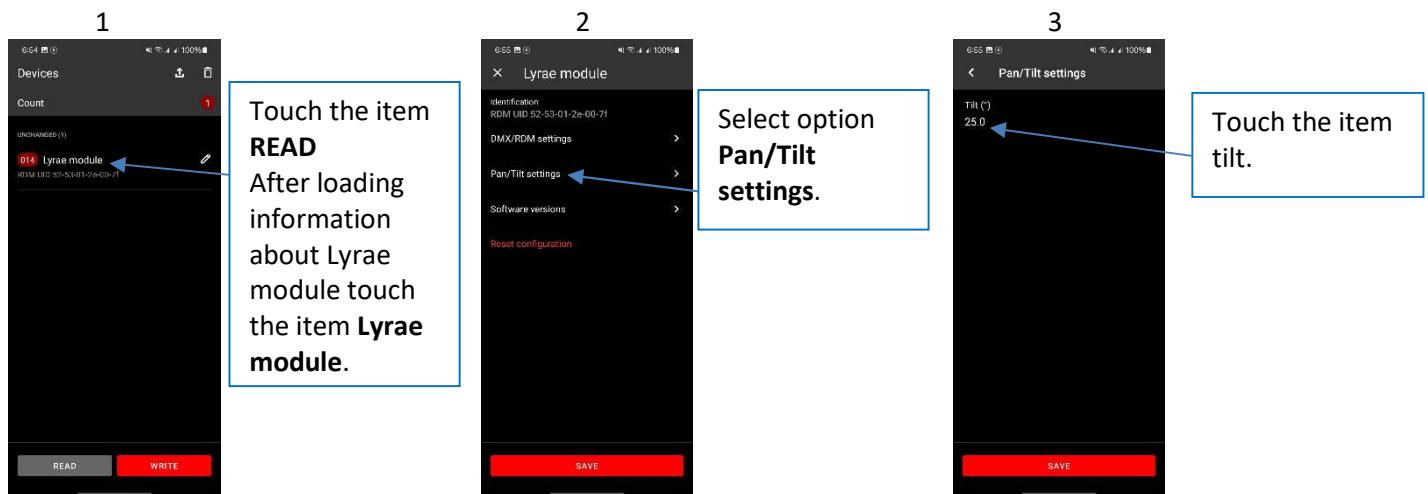

Lyrae M

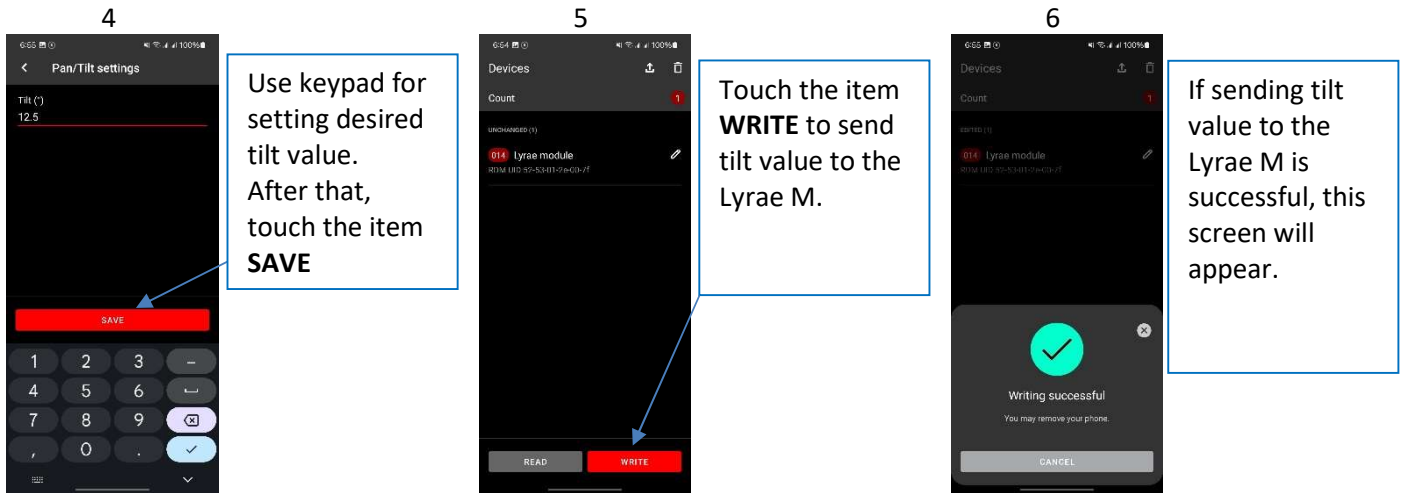

Note. Movement of the light beam is approximately 2-3 seconds delayed after writing a tilt value to the Lyrae M. The tilt setting by NFC is disabled If the Lyrae M is set to DMX mode 10.

DMX.

DMX mode 10 allows you to control tilt of light beam by DMX command. Set tilt value is immediately saved to the Lyrae M.

Note. Last value of the tilt (set by DMX or by NFC) is saved in the Lyrae until another change of the tilt value is done.

5. Software update

Software update of Lyraes has to be done by means of the software ROBE Uploader running on PC.

The ROBE Uploader is a software for automatized software update of ROBE fixtures. The ROBE Uploader switches Lyraes to the update mode automatically.

Please see <https://www.robe.cz/robe-uploader/> for more information.

Note: Lyraes in ON/OFF connection cannot be updated.

DMX connection

For updating of Lyraes, use the file Lyrae.lib.

Example of connection:

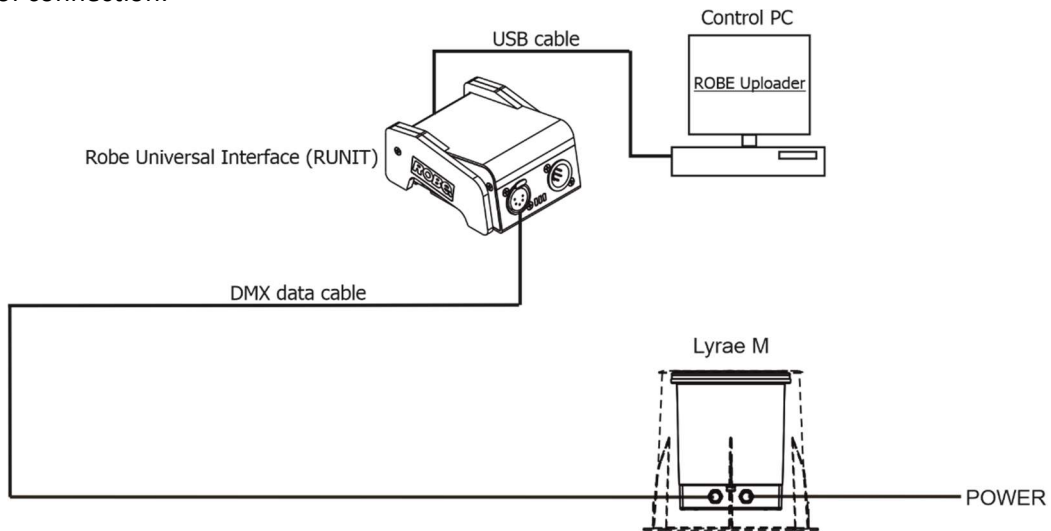

E-box connection

If the option **Standard** is selected from the menu **E-box mode** and LED modules are connected in series, the E-box will be updated including connected Lyrae modules. You have to use the file EminereEbox.lib in the ROBE Uploader for this operating mode.

If the option **Pass-Thr** is selected from the menu **E-box mode** and LED modules are connected in series, you have to do the following steps to update Lyrae M including the E-box:

1. Update connected LED modules by means of the file Lyrae.lib in the ROBE Uploader.
2. Set the E-box to the Standard mode and switch it off/on. Only E-box will be shown in the ROBE Uploader. You have to use the file EminereEbox.lib in the ROBE Uploader for software update of the E-box.
3. After E-box updating, set the E-box to the Pass-Through mode and switch it off/on.

Examples of connection:

1. By means of DMX connection and RUNIT.

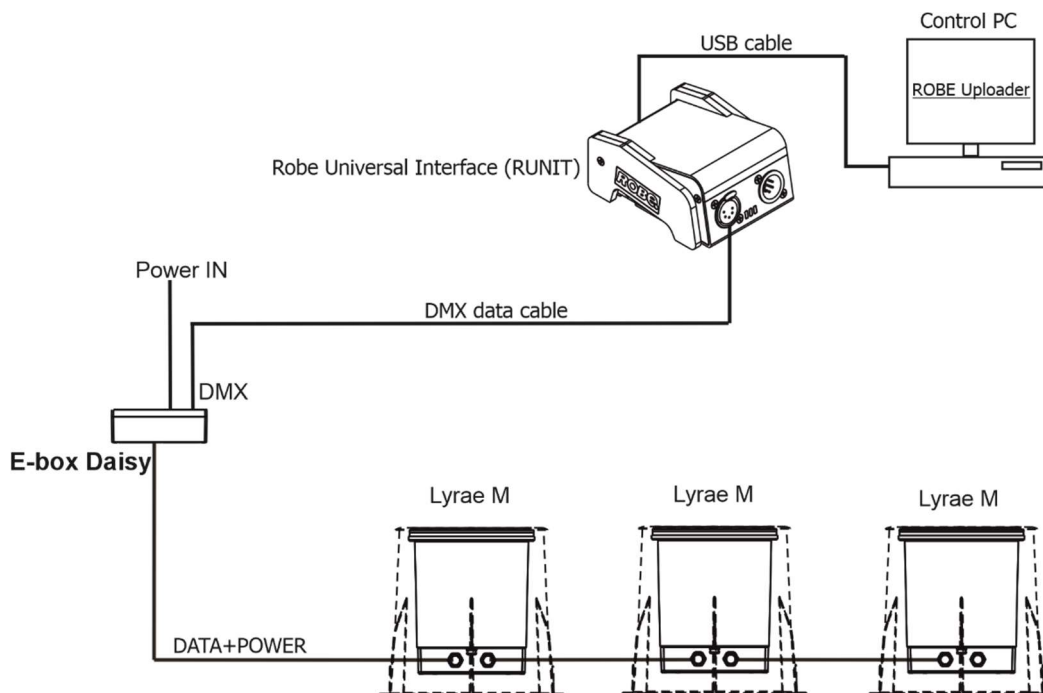

6. Technical specifications

Power supply

- Electronic auto-ranging
- Input voltage: 120 - 277V AC, 50/60 Hz
- Power consumption:
 - Lyrae M SC: 60W
 - Lyrae M MC: 60W
- Inrush current:
 - Lyrae M SC: 65A/230VAC, 30A/115VAC
 - Lyrae M MC: 65A/230VAC, 30A/115VAC

Optical

- Light source:
 - Lyrae M SC: high power single chip LEDs
 - Lyrae M MC: high power multi chip LEDs
- Colour variants:
 - Lyrae M SC: PW (3000 K)
 - Variants on request: (TW (2700 - 6500 K), 2500 K, 2700 K, 3500 K, 4000 K, 5000 K, 6500 K)
 - Lyrae M MC: RGBW (W - 6500 K), RGBA
- Beam angles:
 - Lyrae M SC:
 - Clear glass:
 - symmetrical: 10°, 15°, 25°, 30°, 45°, 65°
 - bi-symmetrical: 10°x30°, 30°x10°, 10°x60°, 60°x10°, 15°x45°, 45°x15°, 30°x60°, 60°x30°
 - Anti-Skid Glass:
 - symmetrical: 18°, 22°, 35°, 50°, 65°
 - bi-symmetrical: 20° x 35°, 35° x 20°, 20° x 65°, 65° x 20°, 20° x 50°, 20° x 50°, 35° x 65°, 65° x 35°
 - Lyrae M MC:
 - Clear glass:
 - symmetrical: 9°, 15°, 25°, 30°, 45°, 65°
 - bi-symmetrical: 10°x30°, 30°x10°, 10°x60°, 60°x10°, 15°x45°, 45°x15°, 30°x60°, 60°x30°
 - Anti-Skid Glass:
 - symmetrical: 18°, 22°, 35°, 50°
 - bi-symmetrical: 20° x 35°, 35° x 20°, 20° x 65°, 65° x 20°, 20° x 50°, 20° x 50°, 35° x 65°, 65° x 35°
- Projected Lumen Maintenance: L90B10 >90.000 hrs, Ta = 25°C / 77°F

Operating modes

- DMX, RDM, DALI 2, On/Off (Single Colour version only), DTP

Settings/Addressing

- E-box, RDM, NFC

Compatible drivers

- E-box Daisy
 - 1 output
 - 1 Main power Input
 - Control: DMX, RDM, Art-Net, sACN, MANet, MANet 2
 - 120-277 V Input

Connection via terminal blocks, inlets via grommet
IP67

- E-box Star
 - 6 outputs
 - 1 Main power Input
 - Control: DMX, RDM, Art-Net, sACN , MANet, MANet 2
 - 120-277 V Input
 - Connection via terminal blocks, inlets via grommet
 - IP67
- E-box Lite
 - 1 output
 - 1 Main power Input
 - Control: DMX, RDM, Art-Net, sACN , MANet, MANet 2
 - 120-277V Input
 - Connection via screw terminal blocks, inlets via grommet
 - IP67

Mounting method

- External mounting sleeve

Adjustability

- Motorized tilt 0-25°

Housing

- High pressure die-cast aluminium body
- Stainless Flange
- Tempered glass

Trim

- Options: Bevel edge trim, Flush trim
- Shape: Round
- Finish options: Stainless steel, Bronze, Brass

Cooling system

- Convection

Total heat dissipation

- Lyrae M SC: 154 BTU/h (calculated)
- Lyrae M MC: 154 BTU/h (calculated)

Protection factor

- CE: IP 68 (8h @ 1m)
- US: Suitable for wet location

Impact rating

- CE: IK10

Max. static load

- Standard tempered glass: 45kN
- Antiskid tempered glass: 23kN

Operating ambient temperature range

- -20°C /+40°C (-4°F /+104°F)

Connection

- Integrated junction box

Cables - CE

- DMX connection: 5-cored cable cable Li9YC11Y 3xAWG16+1x(2xAVG24 Shielded and Jacketed) (P/N 3051508)
- DALI connection: 5-cored cable Belcom B2ca DALI 5X1.5mm2 Hybrid LSZH black (P/N 1305 3693)
- DMX or Ethernet via E-box: 5-cored cable WCA-2.0x3C+(0.2x1P+D+AL)+MY(05) (P/N 13053138)

Cables - US

- DALI connection: Colours of wires apply to the 5-cored cable SJTW 5x 14AWG, black (P/N 13053336)
- DMX or Ethernet via E-box: 5-cored cable WCA-14#x3C+(24#x1P+D+AL)(03) (P/N 13053139)

Weight

- 6.75 kg (14.9 lbs)

Lyrae M

Dimensions (All dimensions in mm [inch])

Lyrae M

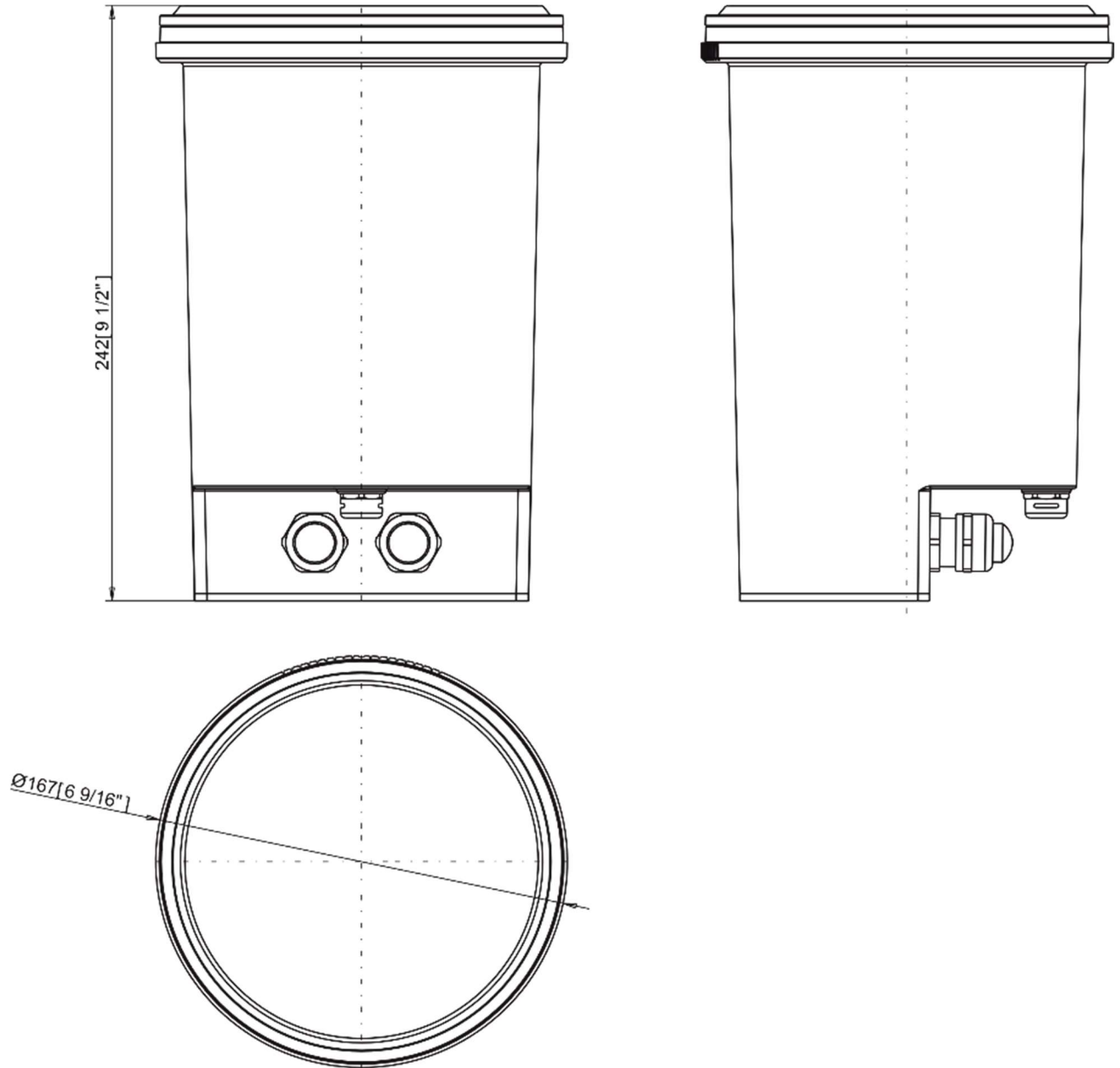

Mounting sleeve

Mounting sleeve with cover for Bevel Edge trim

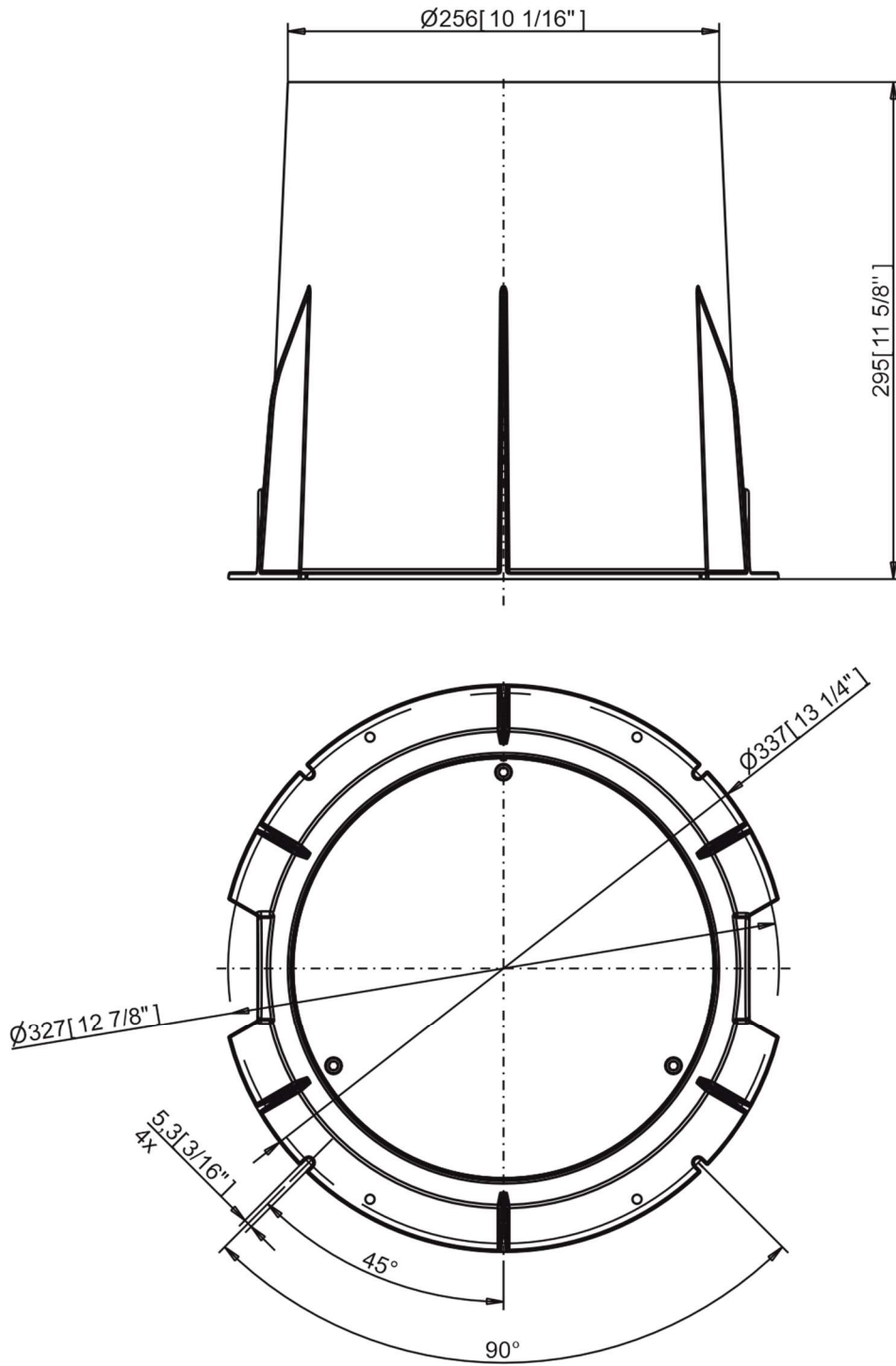

Lyrae M

Mounting sleeve with cover for Flush trim

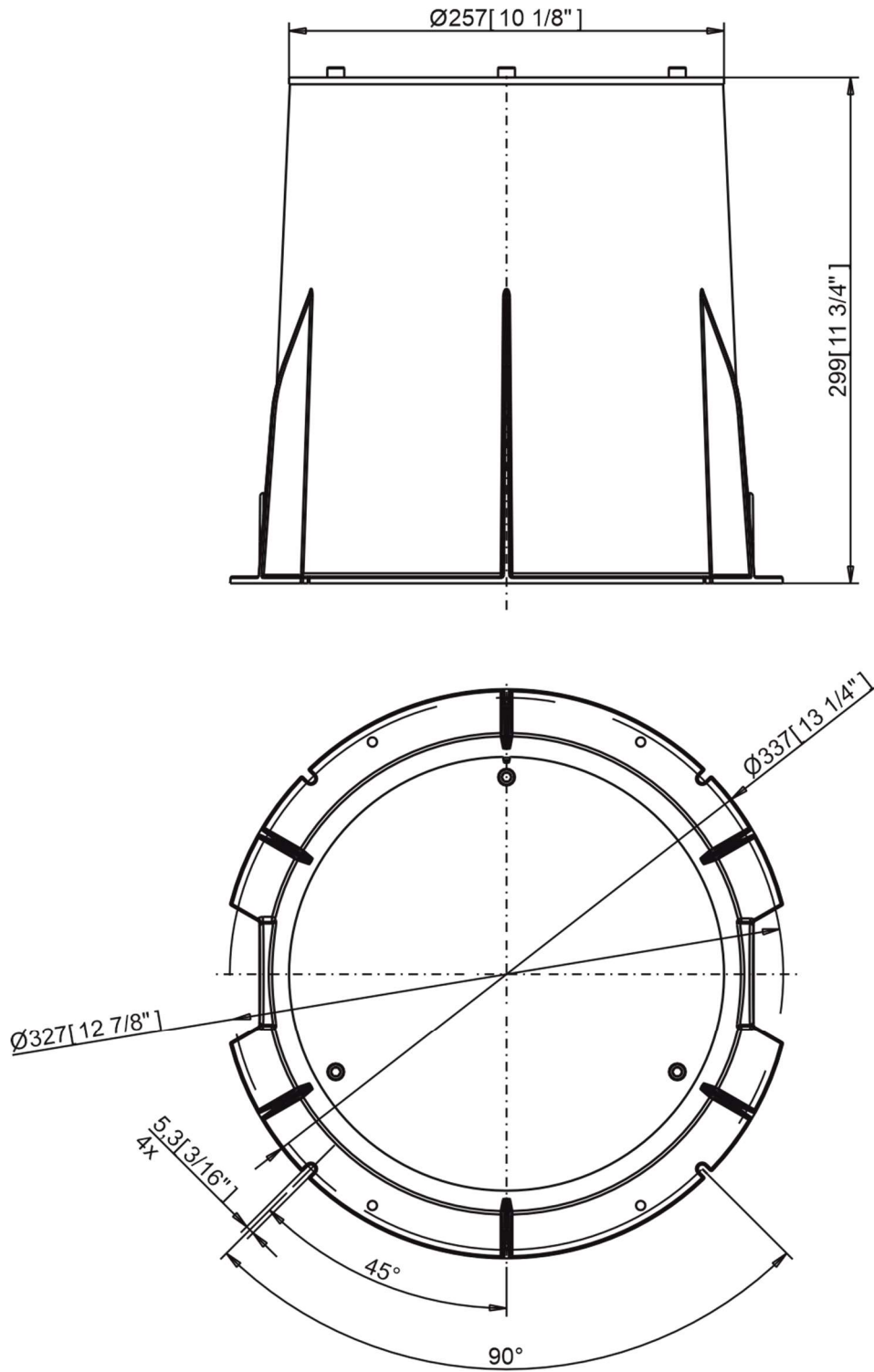

Included items

- 1 x Lyrae M
- 1 x User manual

Accessories (order separately)

P/N 10063655 - E-box Daisy

P/N 10063638 - E-box Daisy/W

P/N 10063657 - E-box Lite

P/N 10063653 - E-box Lite/W

P/N 10063656 - E-box Star

P/N 10063644 - E-box Star/W

P/N 10980997 - Trim for Lyrae M round beveled

P/N 10981021 - Trim for Lyrae M round flush

P/N 10981022 - Trim for Lyrae M square beveled

P/N 10980996 - Mounting sleeve Lyrae M

P/N 10980658 - 3M™ Scotchcast™ Re-Enterable Electrical Insulating Resin 2123

P/N 13053138 - cable WCA-2.0x3C+(0.2x1P+D+AL)+MY(05)

P/N 13053139 - cable WCA-14#x3C+(24#x1P+D+AL)(03)

P/N 1305 3693 - cable Belcom B2ca DALI 5X1.5mm2 Hybrid LSZH black

P/N 13053336 - cable SJTW 5x 14AWG, black

P/N 3051508) - cable Li9YC11Y 3xAWG16+1x(2xAVG24 Shielded and Jacketed)

7. Cleaning and maintenance**DANGER !*****Disconnect from the mains before starting any maintenance or cleaning work***

Rinse off loose dirt with low pressure water spray. Wash the housing with a soft brush or sponge and a mild, non-abrasive washing detergent. Rinse it.

Maintenance and service operations are only to be carried out by a qualified person.

Should you need any spare parts, please use ROBE OEM parts.

7.1 Disposing of the product

To preserve the environment please dispose or recycle this product at the end of its life according to the local regulations and codes.

8. ChangeLog

This section summarizes changes in the user manual.

Version of the manual	Date of issue	Description of changes
1.1	12/09/2024	DMX chart ver. 1.2

Specifications are subject to change without notice.

September 12, 2024

Copyright © 2024 Robe Lighting - All rights reserved

Made in CZECH REPUBLIC by ROBE LIGHTING s.r.o. Palackeho 416/20 CZ 75701 Valasske Mezirici

DMX protocol for Lyrae M, Lyrae S - MC and SC

Version: 1.2 (16 modes in total)

Mode/Channels in all									Mode 1- RGBW(A)-8bit, Mode 2- RGB 8-bit, Mode 3- full RGBW(A)		
1	2	3	4	5	6	7	10	8-9	Mode 4- White-full control, Mode 5- Reduced RGBW(A)		
4	3	12	3	6	8	15	16	Reserved	Mode 6- Reduced RGBW(A)+white control, Mode 7- Full control		
									Mode 7-Full RGBW(A)+virt. Colour wheel, Mode 10 - Tilt control		
									RGBW/RGBA/RGB modes		
Mode/channels								DMX Value	Function	Type of control	
1	2	3	4	5	6	7	10				
-	-	-	-	-	-	1	1		Special functions		
								0	No function	step	
									<i>To activate following functions , stop in DMX value for at least 3 sec.</i>		
								1-2	Save current DMX values to fixture as initial DMX values.	step	
								3-4	Show saved initial DMX values	step	
								5-6	Run factory demo sequences at switching fixture on (without DMX)	step	
								7-8	Insect friendly light On (RGBA version only)	step	
								9-10	Insect friendly light Off (RGBA version only)	step	
								7-255	Reserved		
1	1	1	-	1	1	2	2		Red		
								0 - 255	Red LEDs saturation control (0-100%)	proportional	
-	-	2	-	-	-	3	3		Red Fine		
								0 - 255	Red LEDs saturation control fine	proportional	
2	2	3	-	2	2	4	4		Green		
								0 - 255	Green LEDs saturation control (0-100%)	proportional	
-	-	4	-	-	-	5	5		Green Fine		
								0 - 255	Green LEDs saturation control fine	proportional	
3	3	5	-	3	3	6	6		Blue		
								0 - 255	Blue LEDs saturation control (0-100%)	proportional	
-	-	6	-	-	-	7	7		Blue Fine		
								0 - 255	Blue LEDs saturation control fine	proportional	
4	-	7	-	4	4	8	8		White (Amber)		
								0 - 255	White LEDs saturation control (0-100%)	proportional	
-	-	8	-	-	-	9	9		White (Amber) Fine		
								0 - 255	White LEDs saturation control fine	proportional	
-	-	9	1	-	5	10	10		Green correction		
								0	Uncorrected white	step	
								1-127	Minus green - uncorrected white	proportional	
								128	Uncorrected white (128=default)	step	
								129-255	Uncorrected white - Plus green	proportional	
-	-	10	2	-	6	11	11		Colour temperature correction (CTC)		
								0	No function	step	
								1 - 10	Tungsten dimming 2700 K	step	
								11 - 20	Tungsten dimming 3200 K	step	
								21-255	Colour temperature changing from 1800 K --> 6500 K (21-1800K, 66-2700K, 91-3200K,141-4200K, 211-5600K, 255-6500K)	proportional	
-	-	-	-	-	-	12	12		Virtual Colour Wheel		
								0	No function	step	

DMX protocol

Mode/channels								DMX Value	Function	Type of control
1	2	3	4	5	6	7	10			
								1-2	White 1800 K	step
								3-4	White 2700 K	step
								5-6	White 3200 K	step
								7-8	White 4200 K	step
								9-10	White 5600 K	step
								11-12	White 6500 K	step
								13	Blue (Blue=full, Red+Green+White/Amber=0)	step
								14-23	Red=0, Green->up,Blue =full, White/Amber=0	proportional
								24	Cyan (Red=0, Green=full, Blue =full, White/Amber=0)	step
								25-34	Red=0, Green=full, Blue->down, White/Amber=0	proportional
								35	Green (Red=0, Green=full, Blue =0, White/Amber=0)	step
								36-45	Red->up, Green=full, Blue=0, White/Amber=0	proportional
								46	Yellow (Red=full, Green=full, Blue=0, White/Amber=0)	step
								47-56	Red=full, Green->down, Blue=0, White/Amber=0	proportional
								57	Red(Red=full, Green=0, Blue=0, White/Amber=0)	step
								58-67	Red=full, Green=0, Blue->up, White/Amber=0	proportional
								68	Magenta (Red=full, Green=0, Blue=full, White/Amber=0)	step
								69-78	Red -> down, Green=0, Blue=full, White/Amber=0	proportional
								79	Blue (Red=0, Green=0, Blue=full, White/Amber=0)	step
									Transition effects	
								80-87	Rainbow effect (with fade time) from slow-> fast	proportional
								88-95	Rainbow effect (without fade time) from slow-> fast	proportional
								96-103	Full dynamic white (1800K->6500K->1800K) (with fade time) from slow-> fast	proportional
								104-111	Full dynamic white (1800K->6500K->1800K) (without fade time) from slow-> fast	proportional
								112-119	Dynamic warm white (1800K-3000K-1800K) (with fade time) from slow-> fast	proportional
								120-127	Dynamic warm white (1800K-3000K-1800K) (without fade time) from slow-> fast	proportional
								128-135	Rainbow effect + full dynamic white (with fade time) from slow-> fast	proportional
								136-143	Rainbow effect + full dynamic white (without fade time) from slow-> fast	proportional
								144-151	Blue/Green effect (with fade time) from slow-> fast	proportional
								152-159	Blue/Green effect (without fade time) from slow-> fast	proportional
								160-167	Red/Blue effect (with fade time) from slow-> fast	proportional
								168-175	Red/Blue effect (without fade time) from slow-> fast	proportional
								176-183	Green/Red effect (with fade time) from slow-> fast	proportional
								184-191	Green/Red effect (without fade time) from slow-> fast	proportional
								192-199	Blue/4000K effect (with fade time) from slow-> fast	proportional
								200-207	Blue/4000K effect (without fade time) from slow-> fast	proportional
								208-215	Green/4000K effect (with fade time) from slow-> fast	proportional
								216-223	Green/4000K effect (without fade time) from slow-> fast	proportional
								224-231	Red/4000K effect (with fade time) from slow-> fast	proportional
								232-239	Red/4000K effect (without fade time) from slow-> fast	proportional
							13	13	Shutter/Strobe	
								0-31	Shutter closed	step

DMX protocol

Mode/channels								DMX Value	Function	Type of control
1	2	3	4	5	6	7	10			
								32-63	Shutter open	step
								64-95	Strobe-effect from slow to fast	proportional
								96-127	Shutter open	step
								128-143	Opening pulse in sequences from slow to fast	proportional
								144-159	Closing pulse in sequences from fast to slow	proportional
								160-191	Shutter open	step
								192-223	Random strobe-effect from slow to fast	proportional
								224-255	Shutter open	step
-	-	11	3	5	7	14	14		Dimmer	
								0 - 255	Light intensity coarse (0-100%)	proportional
-	-	12	-	6	8	15	15		Dimmer Fine	
								0 - 255	Light intensity fine	proportional
-	-	-	-	-	-	-	16		Motorized tilt (Lyrae M and Lyrae S only)	
								0 - 255	Tilt movement from 0° to 25°	proportional
Copyright © 2024 Robe Lighting s.r.o. - All rights reserved										
All Specifications subject to change without notice										

DMX protocol for Lyrae M, Lyrae S - MC and SC						
Version: 1.2 (16 modes in total)						
Mode/Channels in all					Mode 11- White selection + Dimmer, Mode 12- WW + CW	
11	12	13	16	14-15	Mode 13- Only Dimmer, Mode 16 - Tilt control	
3	4	2	2	Reserved		
TW and PW modes						
Mode/channels				DMX Value	Function	Type of control
11	12	13	16			
1	-	-	-		White colour selection	
				0 - 255	White from 2700 K - 6500 K	proportional
-	1	-	1		Warm White	
				0 - 255	Warm White LEDs saturation control (0-100%)	proportional
-	2	-	2		Cool White	
				0 - 255	Cool White LEDs saturation control (0-100%)	proportional
2	3	1	3		Dimmer	
				0 - 255	Light intensity coarse (0 - 100%)	proportional
3	4	2	4		Dimmer Fine	
				0-255	Light intensity fine	proportional
-	-	-	5		Motorized tilt (Lyrae M and Lyrae S only)	
				0 - 255	Tilt movement from 0° to 25°	proportional
Copyright © 2024 Robe Lighting s.r.o. - All rights reserved						
All Specifications subject to change without notice						