

**E-box Daisy**

**E-box Star**

**E-box Lite**

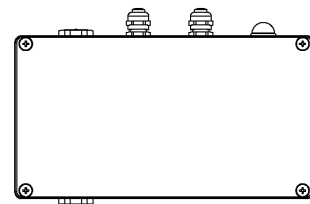
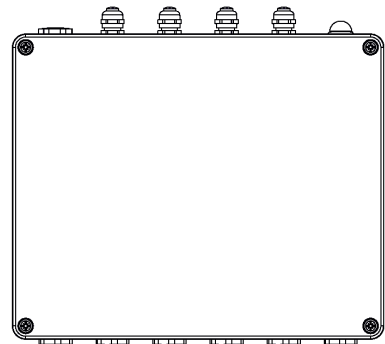
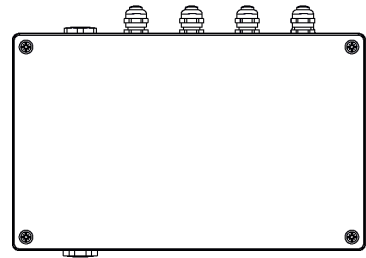

QR code for user manual



# E-box Daisy E-box Star E-box Lite

## Table of contents

<b>1. Safety information</b> .....	<b>3</b>
<b>2. Fixture description</b> .....	<b>5</b>
2.1 E-box Daisy .....	5
2.2 E-box Star .....	7
2.3 E-box Lite .....	9
<b>3. Mounting</b> .....	<b>11</b>
<b>4. Eminere modes</b> .....	<b>17</b>
<b>5. E-box menu</b> .....	<b>22</b>
5.1 DMX Addr .....	22
5.2 Info .....	23
5.3 Personality .....	23
5.4 Special settings .....	24
<b>6. Robe Ethernet Access Portal (REAP)</b> .....	<b>25</b>
6.1 Settings on computer .....	25
6.2 Settings on fixtures.....	25
6.3. REAP menu screens .....	25
6.4 Status screen .....	25
6.5 Personality screen .....	26
6.6 Settings screen .....	26
<b>7. Software update</b> .....	<b>27</b>
<b>8. Technical specifications</b> .....	<b>29</b>
<b>9. Disposing of the product</b> .....	<b>32</b>
<b>10. ChangeLog</b> .....	<b>32</b>

# 1. Safety information

**FOR YOUR OWN SAFETY, PLEASE READ THIS USER MANUAL CAREFULLY  
BEFORE POWERING OR INSTALLING YOUR E-BOX!  
Save it for future reference.**

## **DANGEROUS VOLTAGE CONSTITUTING A RISK OF ELECTRIC SHOCK IS PRESENT WITHIN THIS UNIT!**

Make sure that the available voltage is not higher than stated on the fixture.

Always disconnect the fixture from AC power before removing its cover.

Make sure that the supply cables are not damaged by sharp edges. Check the fixture and the cables from time to time.

Do not install the fixture near an open flame.

This fixture falls under protection class I. Therefore, this fixture has to be connected to a mains socket outlet with a protective earthing connection.

Do not connect this fixture to a dimmer pack.

Do not cover the fixture with cloth or other materials.

The fixture was designed for outdoor use and it is intended for professional application only. It is not for household use.

When choosing the installation spot, please make sure that the fixture is not exposed to extreme heat or dust.

Only operate the fixture after having checked that the housing is firmly closed and all screws are tightly fastened.

Operate the fixture only after having familiarized yourself with its functions. Do not permit operation by persons not qualified to operate the fixture. Most damages are the result of unprofessional operation!

Please consider that unauthorized modifications on the fixture are forbidden due to safety reasons!

Please use the original packaging if the fixture is to be transported.

If this device will be operated in any way different to the one described in this manual, the product may suffer damages and the warranty becomes void. Furthermore, any other operation may lead to dangers like short-circuit, burns, electric shock etc.

The product (covers and cables) must not be exposed to a high frequency electromagnetic field higher than 3V/m.

Immunity of the equipment is designed according to the standard EN 55035 Electromagnetic compatibility of multimedia equipment - Immunity requirements

Emission of the equipment complies with the standard EN55032 Electromagnetic compatibility of multimedia equipment – Emission Requirements according to class B.

This device complies with part 15 of the FCC Rules. Operation is subject to the following two conditions: (1) This device may not cause harmful interference, and (2) this device must accept any interference received, including interference that may cause undesired operation.

Changes or modifications not expressly approved by the party responsible for compliance could void the user's authority to operate the equipment.

The [Device] wireless operation is safe and complies to RF Exposure requirements.

This equipment has been tested and found to comply with the limits for a Class B digital device, pursuant to part 15 of the FCC Rules. These limits are designed to provide reasonable protection against harmful interference in a residential installation. This equipment generates, uses and can radiate radio frequency energy and, if not

installed and used in accordance with the instructions, may cause harmful interference to radio communications. However, there is no guarantee that interference will not occur in a particular installation. If this equipment does cause harmful interference to radio or television reception, which can be determined by turning the equipment off and on, the user is encouraged to try to correct the interference by one or more of the following measures:

- Reorient or relocate the receiving antenna.
- Increase the separation between the equipment and receiver.
- Connect the equipment into an outlet on a circuit different from that to which the receiver is connected.
- Consult the dealer or an experienced radio/TV technician for help.

**ATTENTION!**

**Risque de choc. Couper L'alimentation avant L'entretien.  
Non destine a à un usage domestique**

Convient aux emplacements mouillés.

Ce produit doit être installé selon le code d'installation pertinent, par une personne qui connaît bien les produit et son fonctionnement ainsi que les risques inhérents.

## 2. Fixture description

### 2.1 E-box Daisy

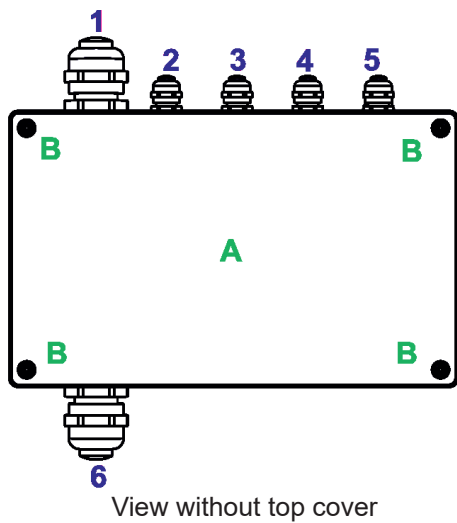

- A - Top cover
- B - Top cover screws
- C - Mounting holes
- D - Antenna cover
- E - Display
- F - Control buttons
- G - Screws of terminal blocks cover
- H - Terminal blocks cover

- 1 - Power IN (cable gland M20x1.5)
- 2 - DMX OUT(cable gland M12x1.5)
- 3 - DMX IN (cable gland M12x1.5)
- 4 - Ethernet OUT (cable gland M12x1.5)
- 5 - Ethernet IN (cable gland M12x1.5)
- 6 - LED Output (cable gland M20x1.5)

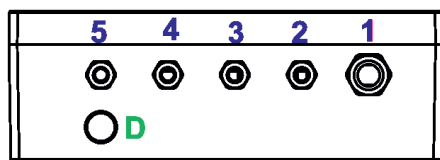
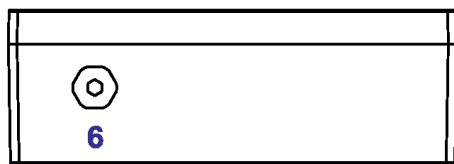
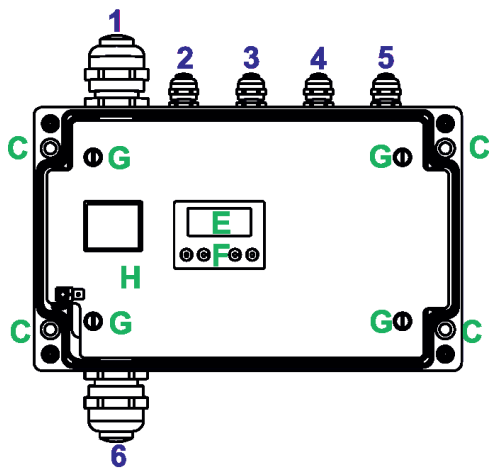

E-Box Daisy - connection points

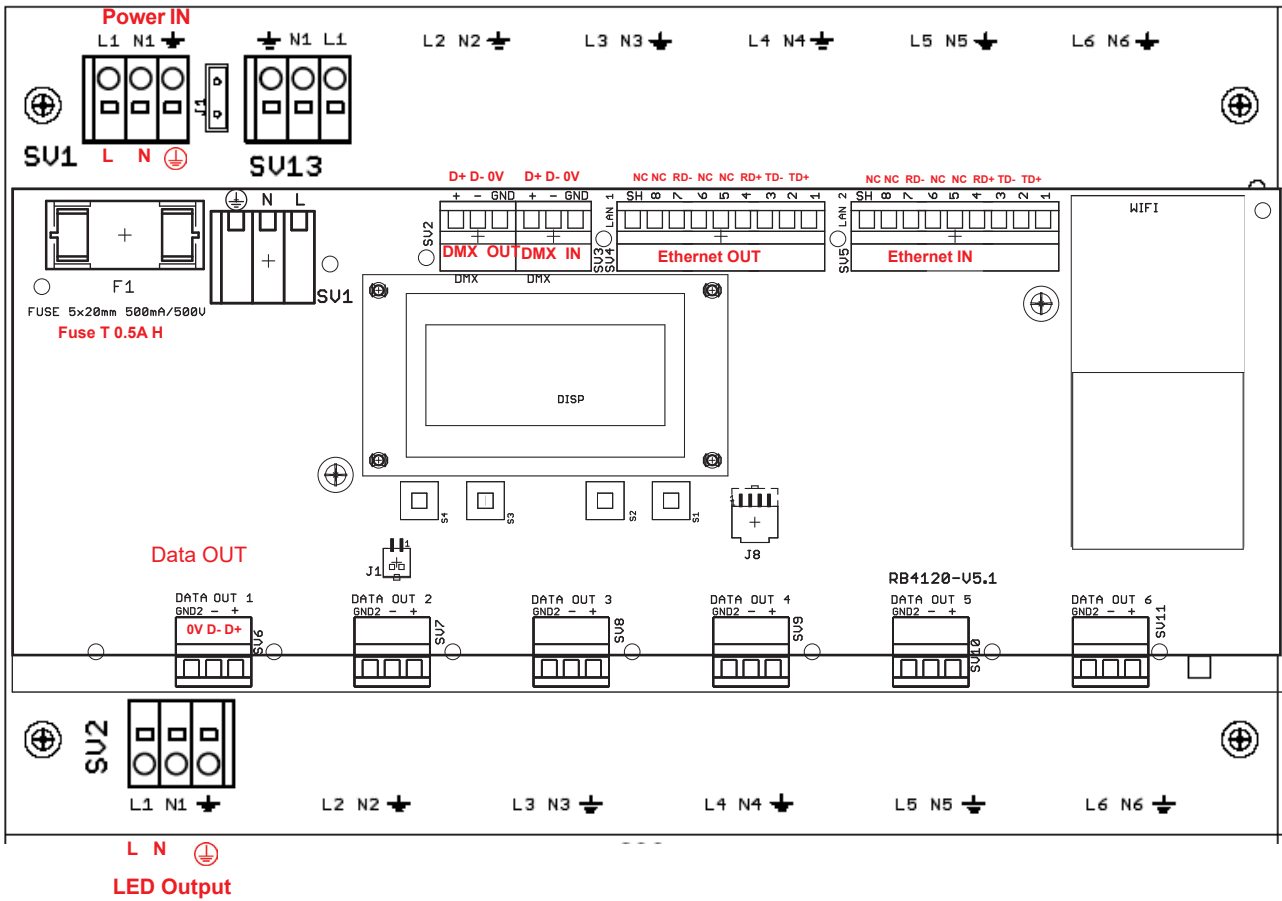

## 2.2 E-box Star

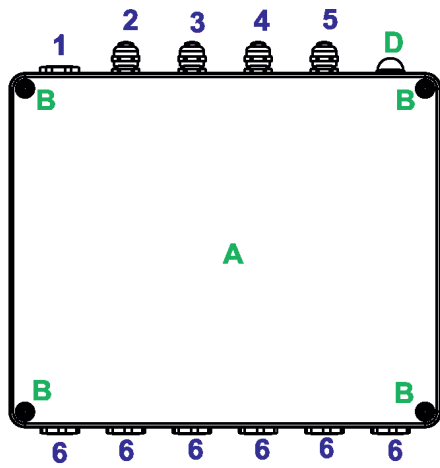

View without top cover

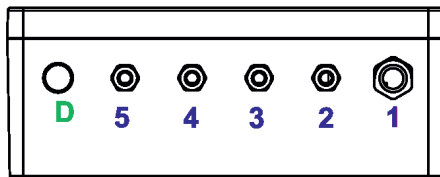
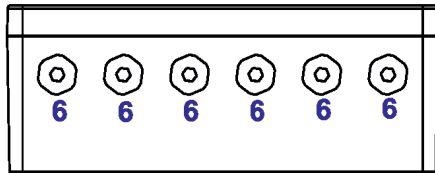
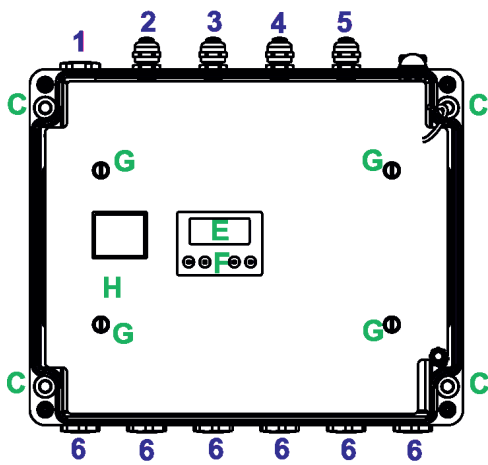

- A - Top cover
- B - Top cover screws
- C - Mounting holes
- D - Antenna cover
- E - Display
- F - Control buttons
- G - Screws of terminal blocks cover
- H - Terminal blocks cover

- 1 - Power IN (filler plug M25 x 1.5/ cable gland M20x1.5)
- 2 - DMX OUT (cable gland M12x1.5)
- 3 - DMX IN (cable gland M12x1.5)
- 4 - Ethernet OUT (cable gland M12x1.5)
- 5 - Ethernet IN (cable gland M12x1.5)
- 6 - LED Outputs (filler plug M25 x 1.5/ cable gland M20x1.5)





## 2.3 E-box Lite

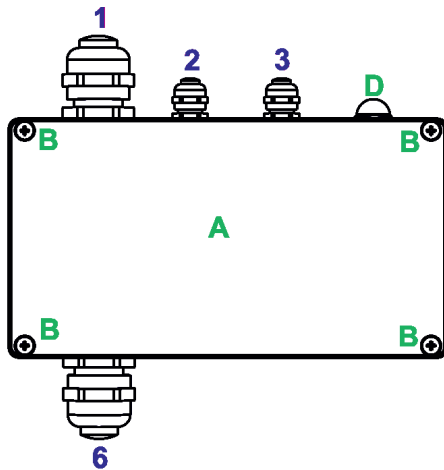

View without top cover

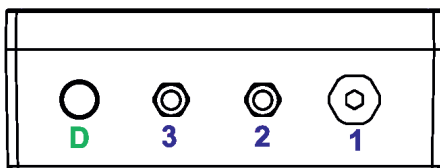
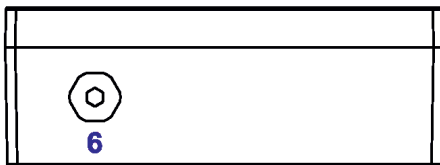
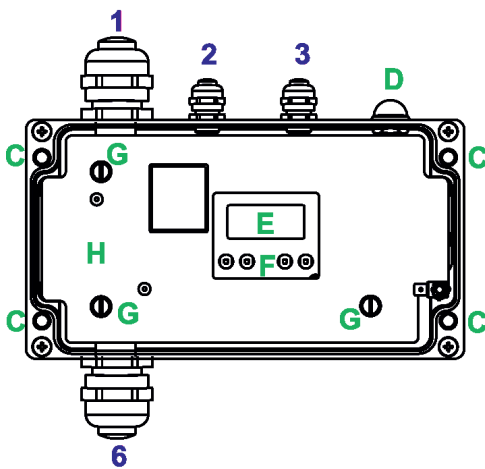

- A - Top cover
- B - Top cover screws
- C - Mounting holes
- D - Antenna cover
- E - Display
- F - Control buttons
- G - Screws of terminal blocks cover
- H - Terminal blocks cover

- 1 - Power IN (cable gland M20x1.5)
- 2 - DMX OUT (cable gland M12x1.5)
- 3 - DMX IN (cable gland M12x1.5)
- 6 - LED Output (cable gland M20x1.5)

# E-Box Lite - connection points

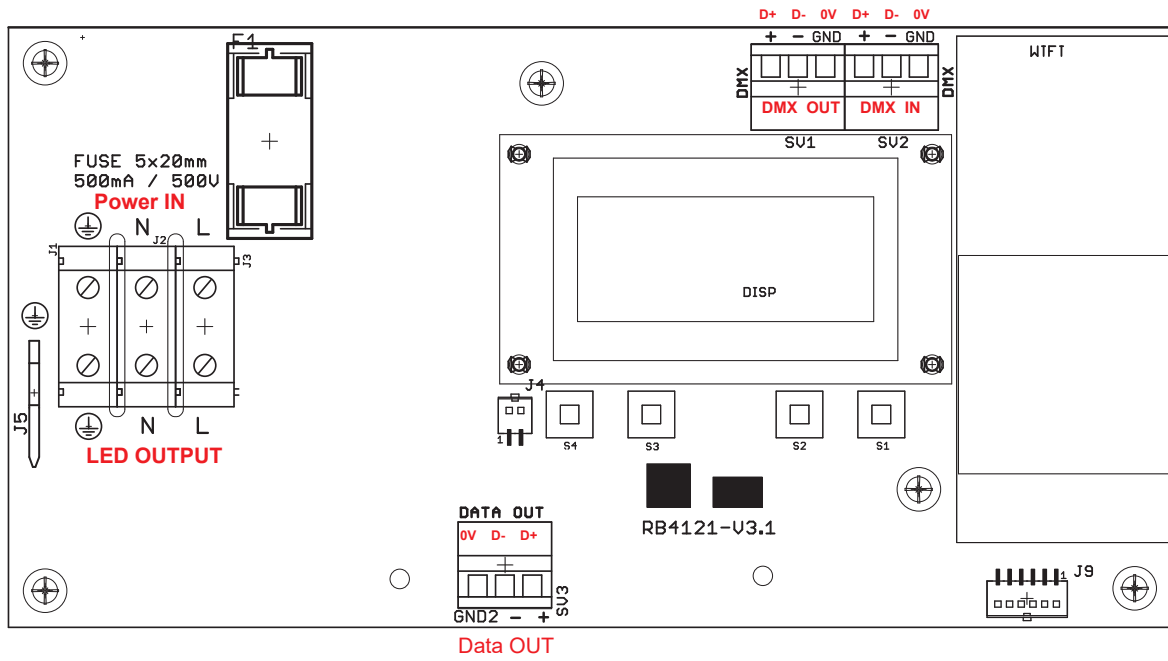

### 3. Mounting

**Fixture must be installed by a qualified electrician in accordance with all national and local electrical and construction codes and regulations.**

**Setting and addressing the E-box without top cover can be done by a qualified person only!**

#### Note for cable glands.

We recommend to apply an adequate layer of the paste LOCTITE 5331 on the plastic holder of the cable gland before inserting it into the body of the gland and an adequate layer of the paste LOCTITE 577 on the thread of the gland body.

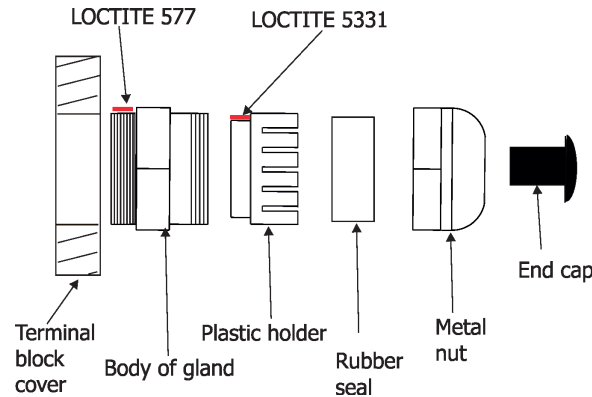

1. Remove the top cover (A) from the E-box by unscrewing four fastening screws (B) in order to get access to the display (E), control buttons (F).
2. Fasten the E-box on a non-flammable flat surface via four mounting holes (C) of a diameter of 6 mm in its housing.
3. Remove the terminal blocks cover (H) from the E-box by unscrewing fastening screws (G) in order to get access to the terminal blocks.
4. Unscrew needed filler plugs M25 x 1.5 (which are installed instead of cable glands M20x1.5) from the housing of the E-box (for E-box Star only) and install cable glands M20x1.5.
5. Pass cables for DMX and Ethernet through cable glands M12x1.5 and connect them to the terminal blocks and tighten the cables in the cable glands.

Note: Remove end caps from cable glands before passing cables. To keep declared IP rating of the device, every cable gland has to be covered with the end cap if the cable gland is not used.

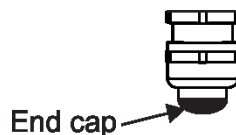

Cable glands serve for cables of the following diameters:

Cable gland M12x1.5 (DMX IN/OUT, Ethernet IN/OUT) - for cable of a diameter of 3-7mm.

Cable gland M20x1.5 (Power IN/ Eminere OUT) - for cable of a diameter of 7-13mm.

6. Check that all screws and cable glands are firmly tightened.
7. Screw the terminal blocks cover (H) back to the E-box.
8. Connect the E-box to mains.
9. Set the E-box by means of the control panel (E) and buttons (F).
10. Disconnect the E-box from mains and screw the cover (A) back on the box.

**ALWAYS DISCONNECT THE E-BOX (and BOOSTER BOX) FROM MAINS BEFORE CONNECTING/DISCONNECTING EMINERE MODULES**

**This device falls under protection class I. Therefore every E-box has to be connected to a mains socket outlet with a protective earthing connection**

### Power connection

	L	N	PE
Core (EU)	Braun	Blue	Green/yellow
Core (US)	Black	White	Green

### DMX connection

D+	D-	0V
Data +	Data -	Data ground (shielding)

### Ethernet connection

Pin	1	2	3	4	5	6	7	8
Function	TD+	TD-	RD+	NC	NC	RD-	NC	NC

### Eminere connection

Cable CE Leader:

Wire	Power Connection	Wire	Data Connection
Brown	L	Orange	Data -
Blue	N	Purple	Data +
Yellow/Green	⊕ (earth)	Shielding	Data ground (0V)

Cable US Leader:

Wire	Power Connection	Wire	Data Connection
Black	L	Orange	Data -
White	N	Red	Data +
Green	⊕ (earth)	Shielding	Data ground (0V)

**Note for Emineres only!** The wiring stated above applies to the Emineres marked X on their labels only. Older versions of Emineres have swapped wires Data - and Data+ ( Orange wire= Data +, Red/Purple wire= Data -) and do not have mark X on their labels.

Example:



This note does not apply for Emineres Side and Emineres Inground

Example of connection

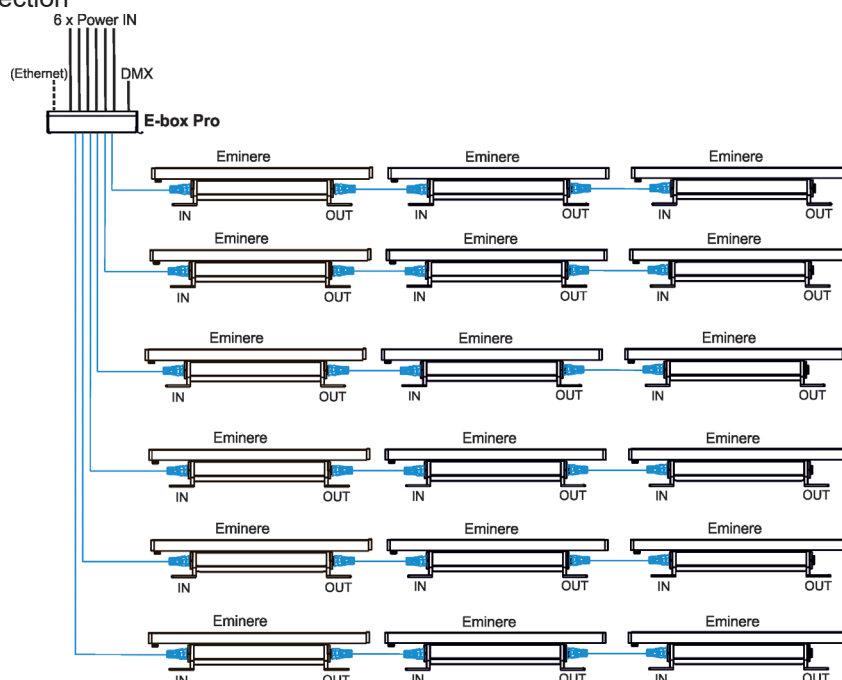

Number of connected Emineres to one LED output of the E-box depends on a cable length, power voltage, type of Eminere and type of E-box and operation mode.

The tables below state max. theoretical number of Emineres connected to the one LED output of the E-box without using Booster boxes. Number of Emineres depends on voltage and cable length.

**The following tables apply for the Standard mode of E-boxes.**

EMINERE 1(Eminere Side 1)	Voltage			
	120V	190V	230V	277V
Cable length *				
10 m	66	104	127	152
20 m	66	104	127	152
30 m	46	104	127	152
50 m	28	70	102	148
70 m	20	50	73	106
100 m	13	35	51	74
200 m	7	17	25	37

EMINERE 2(Eminere Side 2)	Voltage			
	120V	190V	230V	277V
Cable length *				
10 m	36	56	69	83
20 m	36	56	69	83
30 m	24	56	69	83
50 m	15	38	56	80
70 m	10	27	40	57
100 m	9	18	28	40
200 m	3	9	16	20

EMINERE 3(Eminere Side 3)	Voltage			
	120V	190V	230V	277V
Cable length *				
10 m	25	40	48	59
20 m	25	40	48	59
30 m	17	40	48	59
50 m	11	26	39	57
70 m	7	19	28	40
100 m	5	13	19	28
200 m	2	6	10	14

EMINERE 4 (Eminere Side 4)	Voltage			
	120V	190V	230V	277V
Cable length *				
10 m	19	31	37	45
20 m	19	31	37	45
30 m	14	31	37	45
50 m	8	20	30	44
70 m	5	15	21	35
100 m	3	10	15	21
200 m	1	4	7	11

\* Cable length is a total cable length between E-box and last connected Eminere.

Example: Total cable length=L1+L2+L3

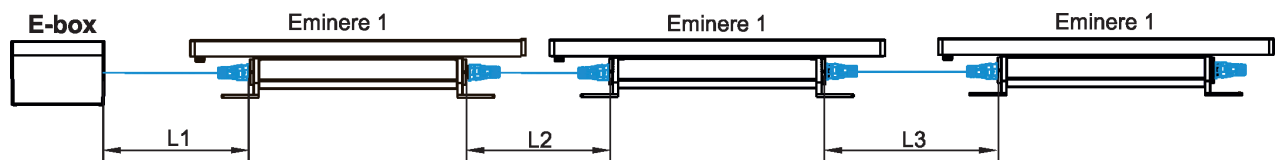

### Important note for E-box Star

The tables for Standard and Pass-Thr mode mode state max. total number of Emineres connected to 6 LED outputs of the E-box Star (or max. number of Emineres connected to one LED output if the rest of LED outputs are not connected). The E-box Star has only one power input!

Example 1:

E-box Star, voltage=230V, cable length=100m, fixture= Eminere 4, total. number of Emineres 4 =16 pcs, without Booster box, Standard mode.

LED Output 1 =4 x Eminere 4

LED Output 2 =4 x Eminere 4

LED Output 3 =4 x Eminere 4

LED Output 4 =4 x Eminere 4

LED Output 5 =not connected

LED Output 6 =not connected

LED Outputs 5 and 6 are free, otherwise max. number of 16 pieces of Eminere 4 will be exceeded.

Example 2:

E-box Star, voltage=230V, cable length=100m, fixture= Eminere 4, total number of Emineres 4 =16 pcs, without Booster box, Standard mode.

LED Output 1 =16 x Eminere 4    LED Output 2 = not connected

LED Output 3 = not connected

LED Output 4 = not connected    LED Output 5 =not connected

LED Output 6 =not connected

Outputs 2,3,4,5,6 to Eminere are free because the max. number of 16 pieces of the Eminere 4 is connected to the output 1.

The following tables apply for the Pass-Thr mode of E-boxes

EMINERE 1(Eminere Side 1)	Voltage			
Cable length *	120V	190V	230V	277V
10 m	32	32	32	32
20 m	32	32	32	32
30 m	32	32	32	32
50 m	32	32	32	32
70 m	25	32	32	32
100 m	17	32	32	32

EMINERE 2(Eminere Side 2, Eminere Inground 2)	Voltage			
Cable length *	120V	190V	230V	277V
10 m	32	32	32	32
20 m	32	32	32	32
30 m	28	32	32	32
50 m	17	32	32	32
70 m	12	31	32	32
100 m	9	21	32	32

EMINERE 3(Eminere Side 3)	Voltage			
Cable length *	120V	190V	230V	277V
10 m	28	32	32	32
20 m	28	32	32	32
30 m	19	32	32	32
50 m	12	29	32	32
70 m	8	21	31	32
100 m	6	15	21	31

EMINERE 4(Eminere Side 4, Eminere Inground 4)	Voltage			
Cable length *	120V	190V	230V	277V
10 m	21	32	32	32
20 m	21	32	32	32
30 m	15	32	32	32
50 m	9	22	32	32
70 m	6	16	23	32
100 m	4	11	16	23

\* Cable length is a total cable length between E-box and last connected Eminere.

Example for Eminere Inground: Total cable length= L1+ΣL2+ΣL3.

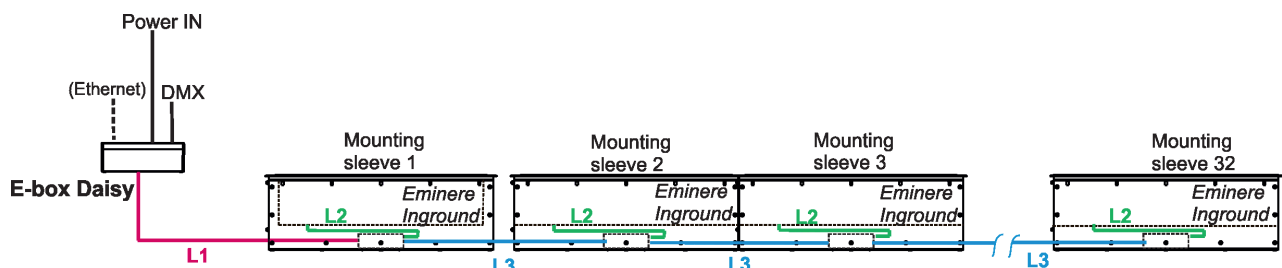

### The Booster box

To compensate a voltage drop in a large installation, the Booster boxes have to be connected in the chain of Eminere modules.

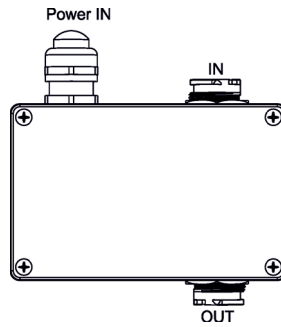

Example: E-box Daisy, Power supply= 230V, Total cable length=70m, Standard mode, type of Eminere: Eminere 2  
The Booster box has to be connected after every 45th Eminere 2 (fixture 45 and fixture 90 from 94 fixtures).

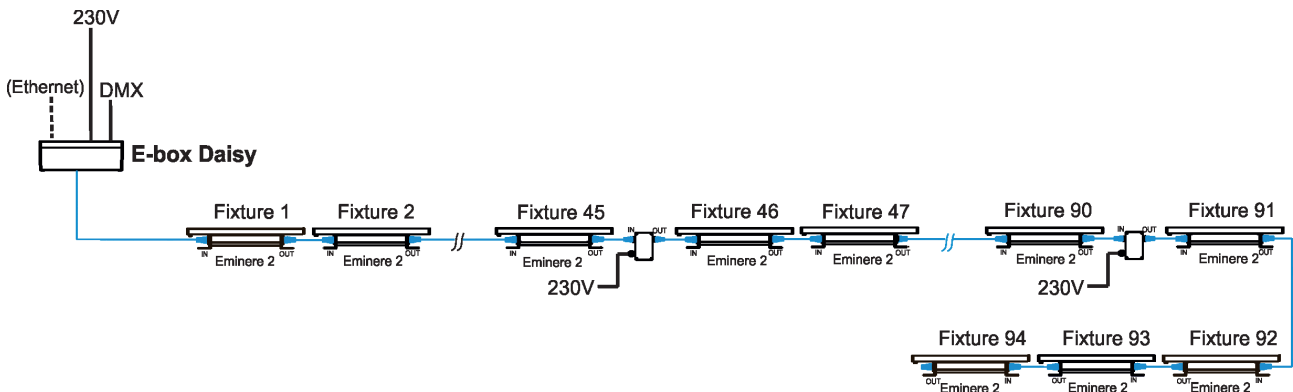

The following tables give numbers of Emineres after which the Booster box has to be installed in the chain of Emineres.

#### Tables for Standard mode

Eminere 1 Eminere Side 1	Max. possible number of Emineres 1= 152			
	Voltage			
Cable length	120V	190V	230V	277V
10 m	66,132	104	127	-
20 m	66,132	104	127	-
30 m	46,92,138	104	127	-
50 m	28,56,84,112,140	70,140	102	148
70 m	20,40,60,80,100,120,140	50,100,150	73,146	106
100 m	13,26,39,52,65,78,91,104, 117,130,143	35,70,105,140	51,102	74,148
200 m	7,14,21,28,35,42,49,56,63,70,77, 84,91,98,105,112, 119,126,133,140,147	17,34,51,68,85, 102,119,136	25,50,75,100,125, 150	37,74,111, 148

EMINERE 2 Eminere Side 2	Max. possible number of Emineres 2= 83			
	Voltage			
Cable length	120V	190V	230V	277V
10 m	36,72	56	69	-
20 m	36,72	56	69	-
30 m	24,48,72	56	69	-
50 m	15,30,45,60,75	38,76	56	80
70 m	10,20,30,40,50,60,70,80	27,54,81	40,80	57
100 m	9,18,27,36,45,56,63,72,81	18,36,54,72	28,56	40,80
200 m	3,6,9,12,15,18,21,24,27,30,33,36, 39,42,45,48,51,54,57,60,63,66, 69,72,75,78,81	9,18,27,36,43,54, 63,72,81	16,32,48,64,80	20,40,60,80

<b>Eminere 3 Eminere Side 3</b>	<b>Max. possible number of Emineres 3= 59</b>			
	<b>Voltage</b>			
<b>Cable length</b>	<b>120V</b>	<b>190V</b>	<b>230V</b>	<b>277V</b>
10 m	25,50	40	48	-
20 m	25,50	40	48	-
30 m	17,34,51	40	48	-
50 m	11,22,33,44,55	26,52	39	57
70 m	7,14,21,28,35,42,49,56	19,38,57	28,56	40
100 m	5,10,15,20,25,30,35,40,45,50,55	13,26,39,52	19,38,57	28,56
200 m	2,4,6,8,10,12,14,16,18,20, 22,24,26,28,30,32,34,36,38,40,4 2,44,46,48,50,52,54,56,58	6,12,18,24,30,36, 42,48,54	10,20,30,40,50	14,28,42,56

<b>Eminere 4 Eminere Side 4</b>	<b>Max. possible number of Emineres 4= 45</b>			
	<b>Voltage</b>			
<b>Cable length</b>	<b>120V</b>	<b>190V</b>	<b>230V</b>	<b>277V</b>
10 m	19,38	31	37	-
20 m	19,38	31	37	-
30 m	14,28,42	31	37	-
50 m	8,16,24,32,40	20,40	30	44
70 m	5,10,15,20,25,30,35,40	15,30	21,42	35
100 m	3,6,9,12,15,18,21,24,27,30,33, 36,39,42	10,20,30	15,30	21,42
200 m	1,2,3,4,5,6.....42,43,44	4,8,12,16,20,24,28, 32,36,40,44	7,14,21,28,35, 42	11,22,33,44

Please see the Eminere user manual for more information about the Booster box installation.

#### Tables for Pass-Thru mode

<b>EMINERE 1 Eminere Side 1</b>	<b>Max. possible number of Emineres 1= 32</b>			
	<b>Voltage</b>			
<b>Cable length</b>	<b>120V</b>	<b>190V</b>	<b>230V</b>	<b>277V</b>
10 m	-	-	-	-
20 m	-	-	-	-
30 m	-	-	-	-
50 m	-	-	-	-
70 m	25	-	-	-
100 m	17	-	-	-

<b>EMINERE 2 Eminere Side 2 Eminere Inground 2</b>	<b>Max. possible number of Emineres 2= 32</b>			
	<b>Voltage</b>			
<b>Cable length</b>	<b>120V</b>	<b>190V</b>	<b>230V</b>	<b>277V</b>
10 m	-	-	-	-
20 m	-	-	-	-
30 m	28	-	-	-
50 m	17	-	-	-
70 m	12,24,	31	-	-
100 m	9,18	21	31	-



EMINERE 3 Eminere Side 3	Max. possible number of Emineres 3= 32			
	Voltage			
Cable length	120V	190V	230V	277V
10 m	28	-	-	-
20 m	28	-	-	-
30 m	19	-	-	-
50 m	12,24	29	-	-
70 m	8,16,24	21	31.	-
100 m	6,12,18,24,30	15,30	21	31

EMINERE 4 Eminere Side 4 Eminere Inground 4	Max. possible number of Emineres 4= 32			
	Voltage			
Cable length	120V	190V	230V	277V
10 m	21	-	-	-
20 m	21	-	-	-
30 m	15,30	-	-	-
50 m	9,18,27	22	-	-
70 m	6,12,18,24,30	16	23	-
100 m	4,8,12,16,20,24,28	11,22	16	23

## 4. Eminere modes

The E-box menu allows you to switch connected LED modules to the two modes:

**Standard** - LED modules are switched to an internal serial connection. DMX addressing of connected LED modules is made automatically (default values are: DMX address=1, DMX Preset = 1), changes can be done by the E-box menu or by RDM. The Standard mode is set as default. E-box and connected LED modules will be shown in the RDM Manager.

**Pass-Thr** - Pass-Trough mode. LED modules are switched to an internal parallel connection. This mode is primarily intended for Emineres Inground. DMX addressing of connected LED modules has to be done manually by means of RDM (software RDM Manager and the device Robe Universal Interface). Only connected LED modules will be shown in the RDM Manager.

Example of the Emineres Inground connection for their addressing.

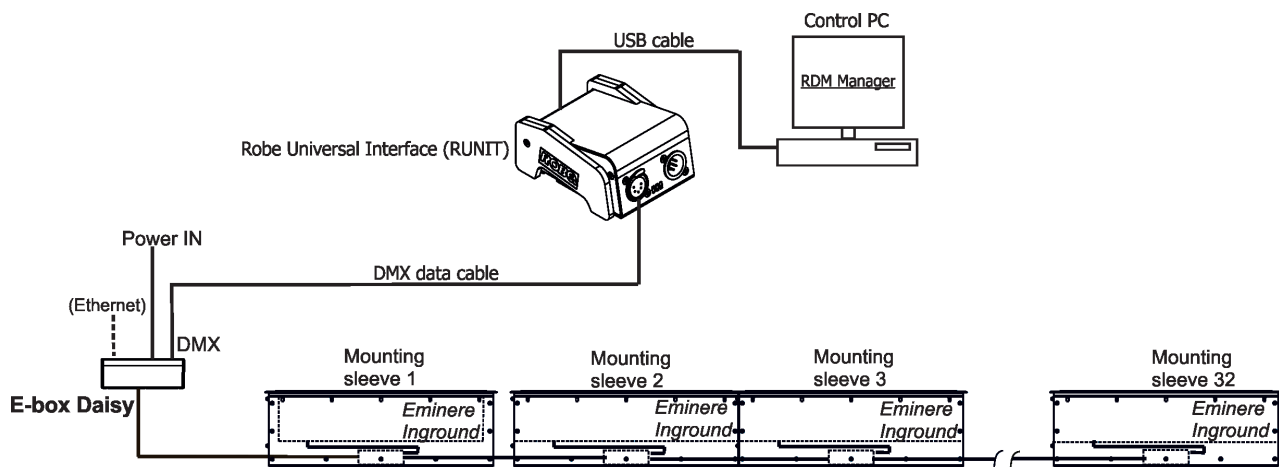

Note: RDM manager and DMX controller cannot run in the same time.

## Examples of RDM manager screenshots.

Initial screen of the RDM manager - Standard mode:

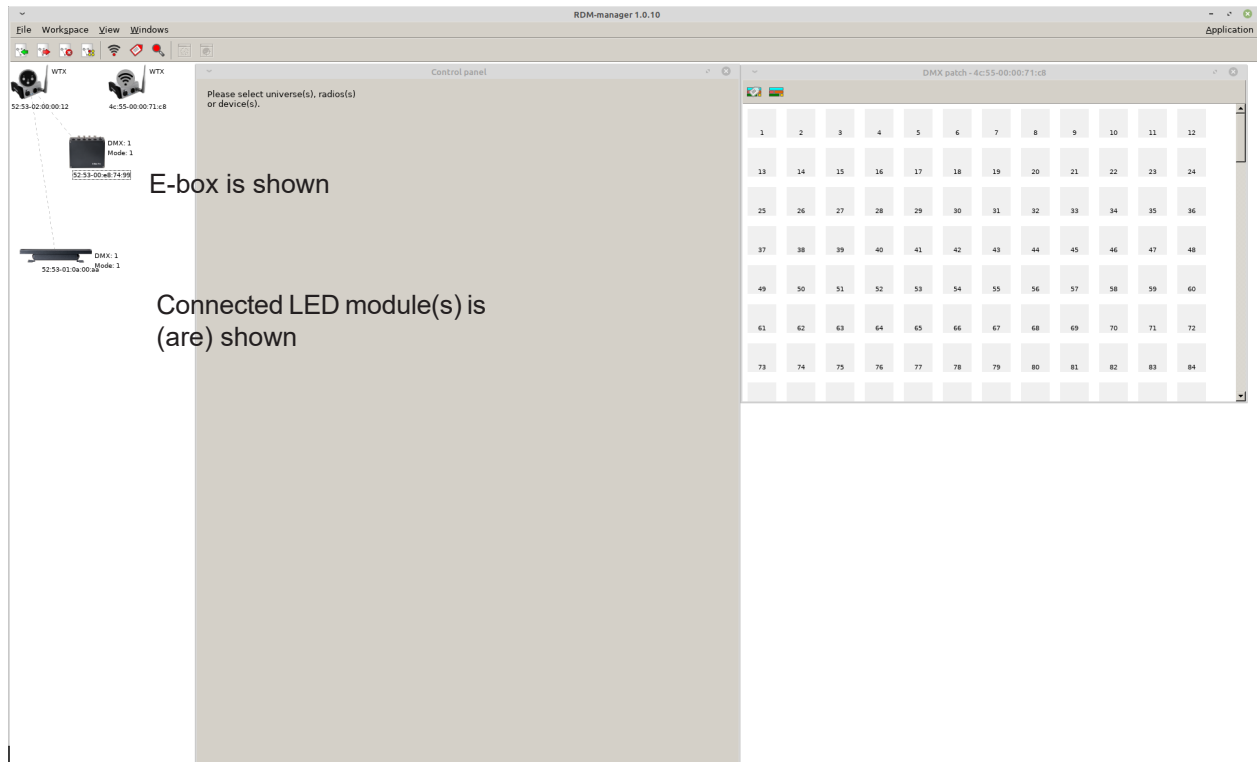

Initial screen of the RDM manager - Pass Through mode:

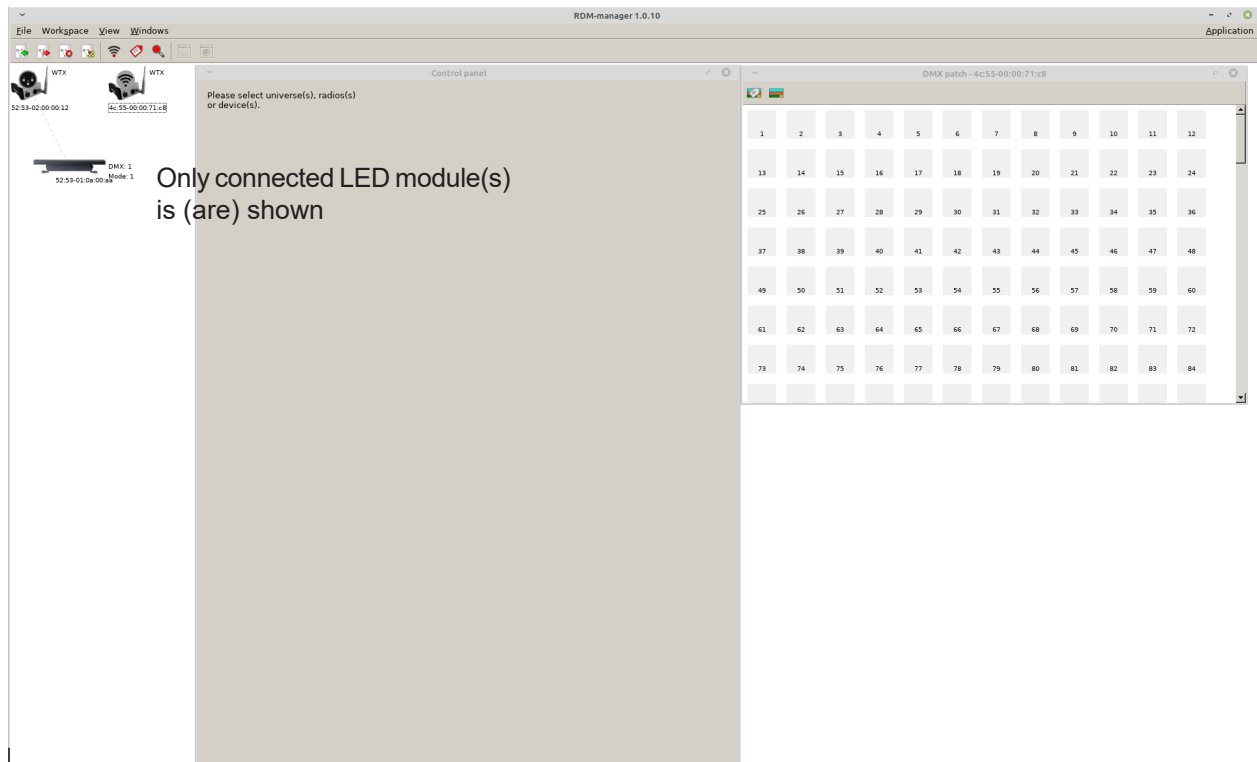

Click on the LED device to show and set options in the Control panel

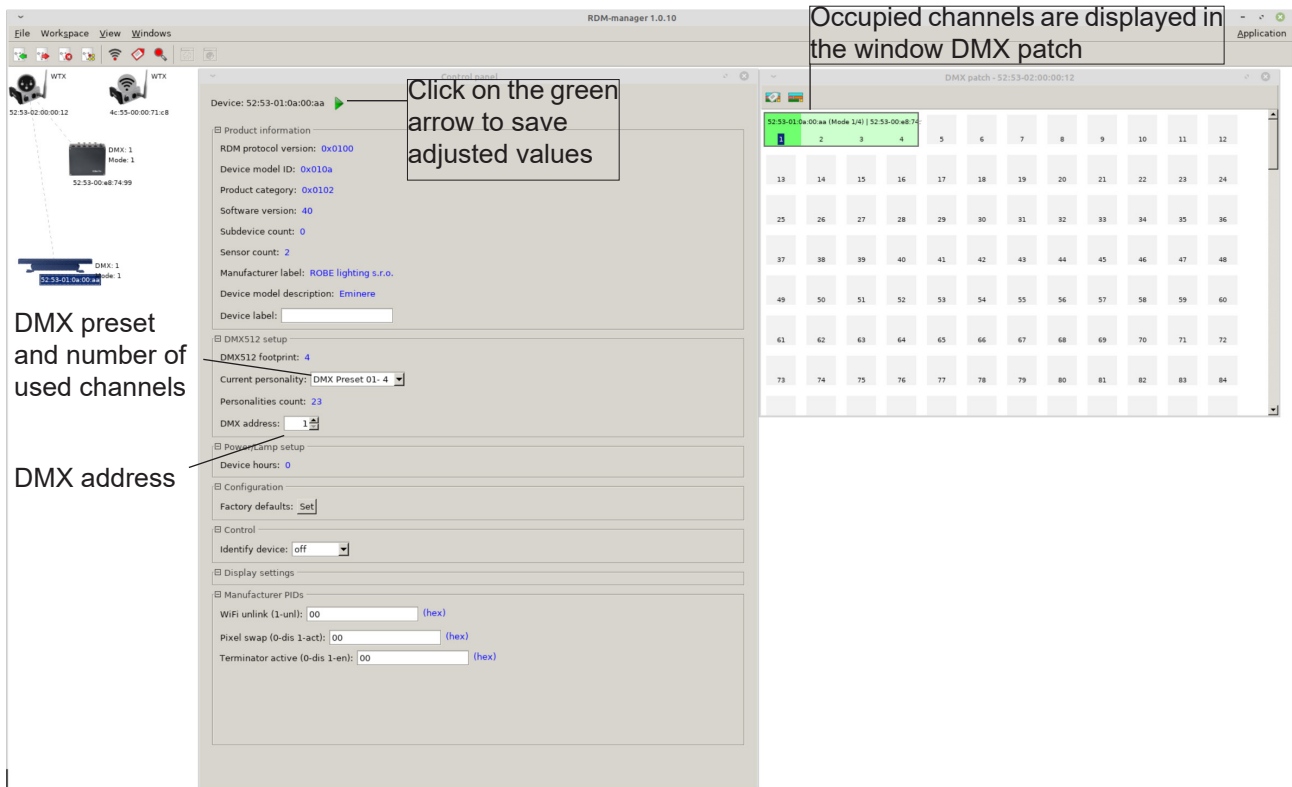

If some DMX Preset shows xx instead of number of channels, it means that DMX preset is reserved for future using (e.g. DMX Presets 8-10).

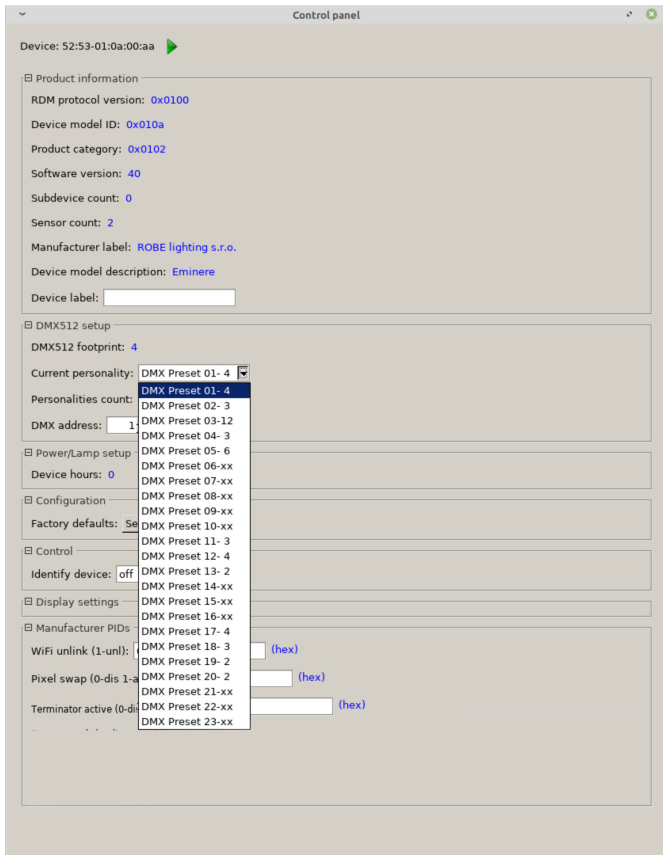

Options in the control panel:

The screenshot shows a 'Control panel' window with the following sections and settings:

- Device:** 52:53-01:0a:00:aa
- Product information:**
  - RDM protocol version: 0x0100
  - Device model ID: 0x010a
  - Product category: 0x0102
  - Software version: 40
  - Subdevice count: 0
  - Sensor count: 2
  - Manufacturer label: ROBE lighting s.r.o.
  - Device model description: Eminere
  - Device label:
- DMX512 setup:**
  - DMX512 footprint: 4
  - Current personality: DMX Preset 01- 4
  - Personalities count: 23
  - DMX address: 1
- Power/Lamp setup:**
  - Device hours: 1
- Configuration:**
  - Factory defaults: Set
- Control:**
  - Identify device: off
- Display settings:**
- Manufacturer PIDs:**
  - WiFi unlink (1-unl): 00 (hex)
  - Pixel swap (0-dis 1-act): 00 (hex)
  - Terminator active (0-dis 1-en): 00 (hex)

Last Eminere on each DMX line may be terminated by setting the 'Manufacturer PID' 'Terminator active' to '1',

Terminator active (0-dis 1-en): 00 (hex)

The option "Pixel swap" from RDM control panel allows you to swap the pixel order.

Example:

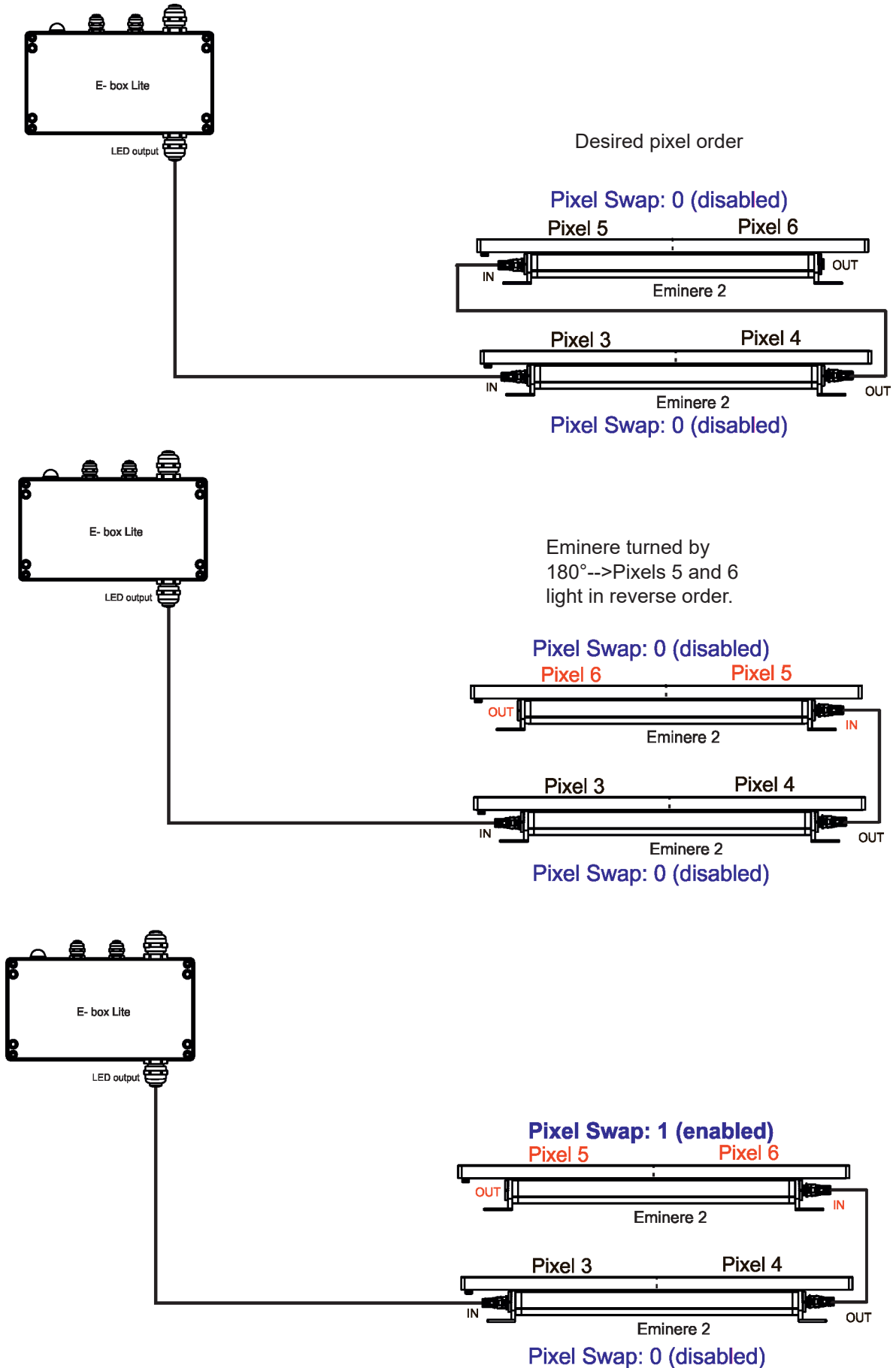

## 5. E-box menu

The E-box is equipped with 2-row LCD display and four buttons which allows to address the fixture and set the fixture's behaviour according to your needs.

The four control buttons have the following functions:

↖ - ESCAPE button- to escape function or menu.

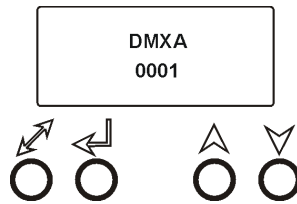

↵ - ENTER button- to select a function or confirm adjusted value.

▲, ▼ - UP and DOWN buttons - to move within the menu.

**When you change any setting of the E-box, disconnect the E-box from power and connect it to power again to activate changes which you have made.**

The connected LED modules can be operated in two modes (menu Special-->E-box mode):

**Standard** - intended for Emineres and Emineres Side

**Pass-Thr** - intended for Emineres Inground, Emineres and Emineres Side.

**Emineres Inground can be operated in the Pass-Thr mode only!**

Some menu items are not accessible if the option Pass-Thr is selected from the menu E-box mode (menu Personality).

These menu items are marked by # in the article below.

### 5.1 DMX Addr

**# Set DMX Address** - use this menu item to set the DMX start address of the fixture, which is defined as the first channel from which the E-box will respond to a DMX controller.

Note: if the option Pass-Thr is selected from the menu E-box mode, the sign "Pass-Thr" is displayed instead of the sign "DMX Addr" and the menu item Set DMX Address is not available.

**IP address\*** - select this menu item to set desired IP address. IP address is the Internet protocol address. The IP uniquely identifies any node (fixture) on a network. There cannot be 2 fixtures with the same IP address on the network!

**Default Address.** This address is derived from fixture's MAC address and cannot be changed. Confirm the item **"Set Address"** to select this address.

**Custom Address.** IP address consists of four decimal numbers, each ranging from 0 to 255, separated by dots, e.g., 172.16.254.1. Each part represents a group of 8 bits (octet) of the address.

The following items **"IP Adr 1"**, **"IP Adr 2"**, **"IP Adr 3"**, **"IP Adr 4"** allow you to set each part (number) of the address. After setting desired IP address, confirm the item **"Set Address"** to save this address.

**Network mask\*** - select this menu item to set desired network mask. A network mask is a 32-bit mask used to divide an IP address into subnets and specify the networks available hosts.

The following items **"Net M.1"**, **"Net.M.2"**, **"Net.M.3"**, **"Net.M.4"** serve for setting of each part (number) of the net mask.

After setting desired network mask, confirm the item **"Set Net M."** to save adjusted values.

\* E-box Daisy, E-box Star only.

## 5.2 Info

Use this menu to read useful information about the fixture.

**Software version** - select this menu item to read software versions of the E-box and connected Emineres.

**Databox** - version of the E-box.

**WL** - version of installed wireless DMX module.

**IP Addr** - - **IP address**. This menu item shows the current IP address (the IP address "runs" on display).

**RDM UID** - - **RDM UID**. Select this menu item to read the RDM UID (the RDM UID "runs" on display).

**MAC Addr** - - **MAC Address**. Select this menu item to read the MAC address (the MAC address "runs" on display).

**# Outputs Info** - information about Emineres connected to the LED outputs.

Example:

**Output 1 Info** .....information about E-box output 1

**Fixtures Cnt: 12**.....Number of connected Emineres to the selected output.

If some Eminere output is not used, the message "No output" will be displayed.

**Temp** - **Temperature**. Temperature inside the E-box.

## 5.3 Personality

Use this menu to modify the E-box operating behaviour.

**# Devices** - use this menu to find and set connected LED modules.

**Search** – The menu item finds connected Emineres Remote. After finishing searching procedure, number of found LED modules will be displayed and if you want to founded LED modules save, select the option Y (option N leaving the menu without saving) and press the ENTER button.

**Sort** – The option allows you to sort LED modules according selected DMX preset for colour variant. Option **Default** means that LED modules will be sorted according last DMX preset (LED module remembers its last DMX mode, in case of change of the E-box you do not need to set DMX mode for each LED module, sorting will be done according last DMX mode).

Note: Default DMX mode for new LED modules (default from factory) is first DMX mode for corresponding colour variant of the LED module (Mode 1-for RGBW/RGBA variant, Mode 11-for TW and PW variant).

**Settings** – The menu item allows you to select desired LED output and display LED modules connected to the LED outputs. The LED modules are identified by RDM UID. At every LED module you can change DMX address and DMX preset.

Note: If you change DMX address or DMX preset, you will need to run the procedure Sort again and new footprint will be saved.

**Locate** – The menu item allows you to identify LED modules, selected LED module will light.

**DMX Input** - this menu allows you to choose desired DMX data input:

**Wired DMX** - DMX signal is received by means of the standard DMX cable.

**Wireless\*** - DMX signal is received by means of the inbuilt wireless DMX module.

**Wireless Out DMX\*** - the fixture receives wireless DMX and sends the signal to its wired DMX output. The fixture behaves as a "Wireless/Wired" adapter.

**Ethernet\*\*** - DMX signal is received by means of the Ethernet cable.

\* If wireless DMX module is installed.

\*\* E-box Daisy, E-box Star only.

**Ethernet Settings\*\*** - use the menu item to select and set desired operating mode.

**Ethernet mode** - use the menu to select a protocol.

**Artnet** - fixture receives Artnet protocol

**sACN** - fixture receives sACN protoco

**gMAI** - fixture receives MANet 1 protocol

**gMAII** - fixture receives MANet 2 protocol

**ArtNet Settings** - use the menu item to set parameters for ArtNet operation.

**ArtNet Uni. 1** - selection of the ArtNet Universe (1-12)

**Net** - selection of a network (0-127)

**Sub-Net** - selection of a subnet (0-15).

**Universe** - selection of an Universe (0-15).

Menu items "ArtNet Uni. 1 " and "Universe" allow a "crossing of Universes".

**sACN Settings** - use the menu item to set parameters for sACN operation.

**sACN Uni** - selection of the sACN Universe (1-12). To the selected universe can be assigned universe from range of 1-63999. It allows a "crossing of Universes".

**MANet Settings** - Use this menu to set parameters for MANet operation.

**MA. Uni** - MANet I (II) universe. The value of this item can be set in range of 1-256.

**MA. S. ID** - MANet I(II) session ID. The value of this item can be set in range of 1-32.

**IGMP rep** - Repeating time for Internet Group Management Protocol (Off, 1sec-10sec).

\*\* E-box Daisy, E-box Star only.

**Display Settings** - this menu allows you to change the display settings.

**Display Off Timer** - if this item is on, the display will be switched off 2 minutes after last pressing any button on the control panel.

**Display Lightness** - select this menu item to adjust the display intensity (0-100%).

**Display Contrast** - select this menu item to adjust contrast of the display (0-100%).

**#DMX Hold** - If the function is on, the fixture keeps last received DMX values in case that DMX data receiving was interrupted (e.g. disconnected DMX cable or DMX controller ).

**E-box mode** - this menu item allows you to select a way of Emineres connection.

**Standard** - Emineres are switched to the internal serial connection.

**Pass-Thr** - Emineres are switched to the internal parallel connection. This option has to be selected if the Eminere Inground modules are connected to the E-box.

The Emineres and Emineres Side can be switched to the Standard or to the Pass-Thr mode

The Emineres Inground can be switched to the Pass -Thr mode only.

**Important. Switch Off/On the E-box after changing the E-box mode.**

**Default setting** - select this option to set fixture personalities to the default (factory) values.

## 5.4 Special settings

**Wireless\*** - **Wireless DMX information.** The menu allows to read some information about Wireless DMX operation

**Stat - Wireless status.** Use the menu to read wireless DMX status.

**Unlink** - use this item to unlink the fixture from wireless DMX.

\* If wireless DMX module is installed.

**Software Update** - The menu item switches the the E-box to the update mode.

If the software update is done by means of the software ROBE RDM Uploader, switching the E-box to the update mode will be done automatically.



## 6. Robe Ethernet Access Portal (REAP)

### 6.1 Settings on computer

Your computer needs to be connected to the fixtures through the means of Ethernet wired network and a network switch. The computer needs to have configured network settings in order to be able to communicate with the fixtures through the network.

To do this, refer to the manual of your computer how TCP/IP network settings should be done. Set up manual IP address of your computer. The Ethernet network connection (Local LAN) typically needs to be set to 2.x.x.x address, for example 2.0.0.10, assuming that no other computer on the network contains such an address while keeping all ROBE fixtures in default IP settings. Netmask of the computer should be 255.0.0.0

### 6.2 Settings on fixtures

Typically, make sure to use the default 2.x.x.x IP address as provided. There is no need to set the fixture into Art-Net mode.

### 6.3. REAP menu screens

Type the IP address of the ROBE fixture to your web browser, e.g. <http://2.247.92.33>, enter the user name: **robe** and the password: **2479**, the first menu screen of the ROBE fixture will appear.

### 6.4 Status screen

The screen gives you a fast overview of fixture settings.

The screenshot shows the ROBE REAP status screen for an Eminere Ebox fixture. The top navigation bar includes 'Status', 'Personality', and 'Settings'. The main content area is titled 'Device status' and contains several panels:

- DMX/RDM settings** (gear icon):
  - DMX address: 1
  - DMX preset: pixel
  - DMX input: ethernet
  - IP address: 2.245.20.82
  - Network mask: 255.0.0.0
  - MAC address: 00:9d:19:04:14:52
  - RDM UID: 52:53:00:e8:14:52
  - RDM label: Eminere Ebox
- Outputs state**:
  - Receiving data: no
  - Total footprint: 0
- Device temperatures**:
  - Driver board: 40°C current
- Wireless state** (gear icon):
  - State: linked
  - Signal strength: 0.0%
- Software versions**:
  - Databox: 3.9
- Status messages**: (empty)

The background colour of the top row of the screen with the name and RDM label of the fixture denotes state of the fixture:

- Black colour - fixture is ready for operation
- Yellow colour - fixture does not communicate with computer
- Red colour - fixture with error messages

The icon  allows you to change some values in a corresponding table.

## 6.5 Personality screen

The screen allows you to change some fixture settings by clicking on the icon  in a corresponding table .

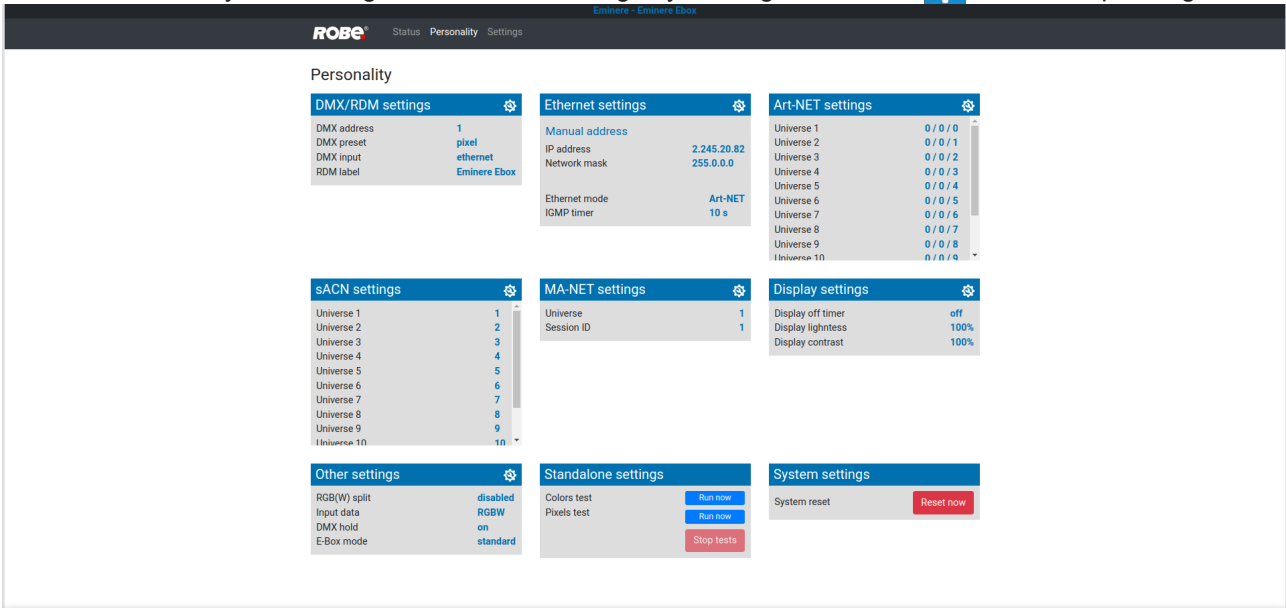

**Personality**

**DMX/RDM settings**

DMX address	1
DMX preset	pixel
DMX input	ethernet
RDM label	Eminere Ebox

**Ethernet settings**

Manual address	
IP address	2.245.20.82
Network mask	255.0.0.0
Ethernet mode	Art-NET
IGMP timer	10 s

**Art-NET settings**

Universe 1	0 / 0 / 0
Universe 2	0 / 0 / 1
Universe 3	0 / 0 / 2
Universe 4	0 / 0 / 3
Universe 5	0 / 0 / 4
Universe 6	0 / 0 / 5
Universe 7	0 / 0 / 6
Universe 8	0 / 0 / 7
Universe 9	0 / 0 / 8
Universe 10	0 / 0 / 9

**sACN settings**

Universe 1	1
Universe 2	2
Universe 3	3
Universe 4	4
Universe 5	5
Universe 6	6
Universe 7	7
Universe 8	8
Universe 9	9
Universe 10	10

**MA-NET settings**

Universe	1
Session ID	1

**Display settings**

Display off timer	off
Display lightness	100%
Display contrast	100%

**Other settings**

RGB(W) split	disabled
Input data	RGBW
DMX hold	on
E-Box mode	standard

**Standalone settings**

Colors test	<a href="#">Run now</a>
Pixels test	<a href="#">Run now</a>
	<a href="#">Stop tests</a>

**System settings**

System reset	<a href="#">Reset now</a>
--------------	---------------------------

## 6.6 Settings screen

The screen allows you to change password to REAP.

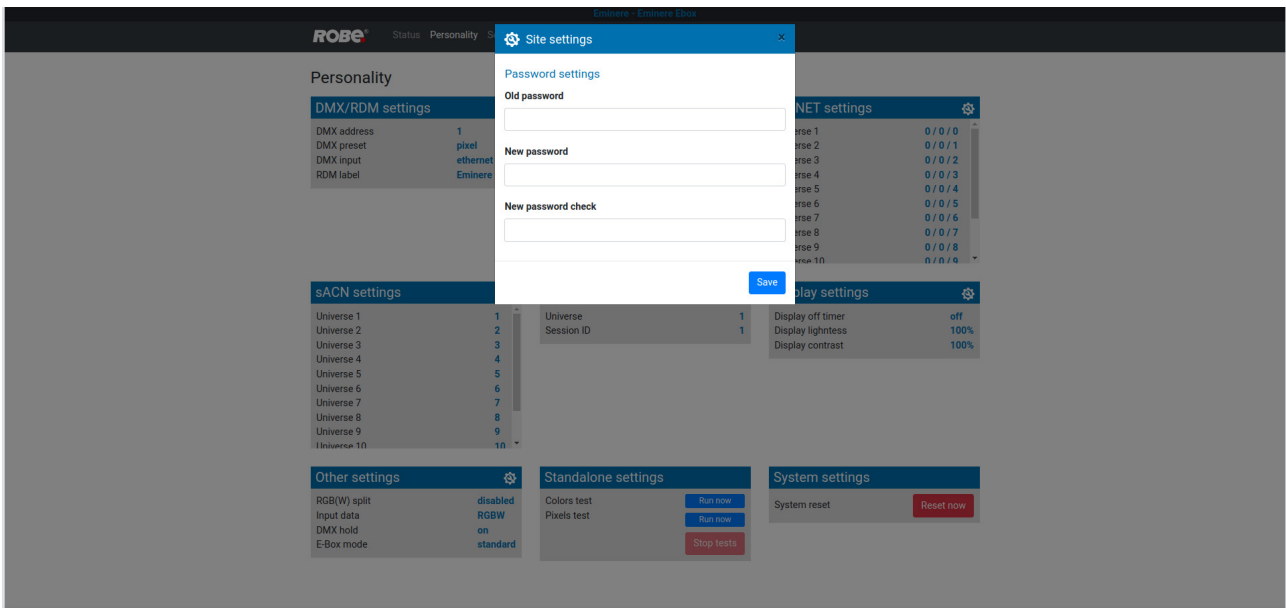

**Site settings**

**Password settings**

Old password

New password

New password check

[Save](#)

## 7. Software update

E-box software update can be done via an Ethernet connection between a computer running a ROBE Uploader software and E-box or using the Robe Universal Interface (Robe Universal Interface WTX), DMX connection and the ROBE Uploader software. The ROBE Uploader is a software for automatized software update of ROBE fixtures. The ROBE Uploader switches E-box to the update mode automatically.

Please see <https://www.robe.cz/robe-uploader/> for more information about the ROBE Uploader.

**After updating the E-box from older version to version 4.0, the E-box and connected Eminere modules will be set to default (factory) values including DMX presets and addresses! Setting of Calumma modules will not be changed.**

**Update from version 4.0 to newer version will not affect setting of the E-box Remote and connected Eminere and Calumma modules.**

**Version of the Robe uploader has to be 4.16 and higher.**

1. Option “**Standard**” is selected from the menu “E-box mode” and LED modules are connected in series, the E-box will be updated including connected LED modules. Only E-box will be shown in the ROBE Uploader. You have to use the file EminereEbox.lib in the ROBE Uploader for this operating mode.



Note: File EminereEbox.lib includes software for E-box Daisy/Star/Lite, E-box Remote, Emineres, Emineres Side, Emineres Inground, Emineres UV, Emineres Remote, Emineres Remote UV and Calummas XL/L/M/S/XS.

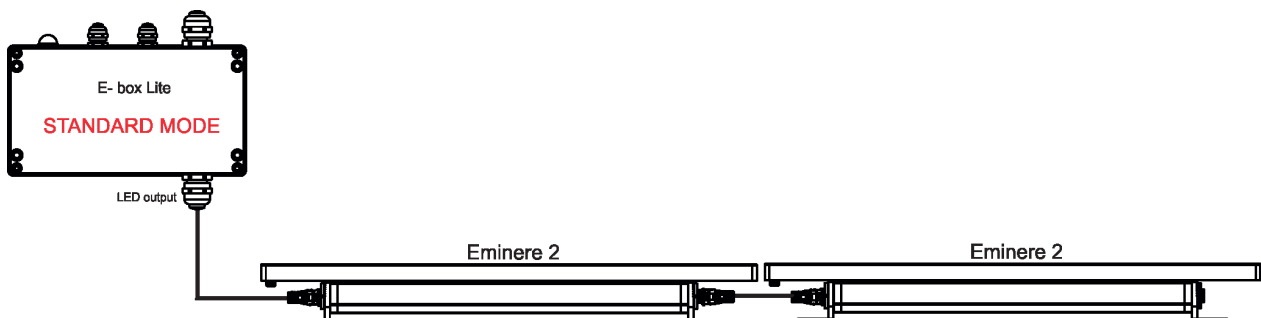

2. Option “**Pass-Thr**” is selected from the menu “E-box mode” and LED modules are connected in series. Set the E-box to the Standard mode and switch it off/on. Only E-box will be shown in the ROBE Uploader. You have to use the file EminereEbox.lib in the ROBE Uploader for software update of the E-box and connected LED modules.

After updating, set the E-box to the Pass-Thorough mode and switch it off/on.

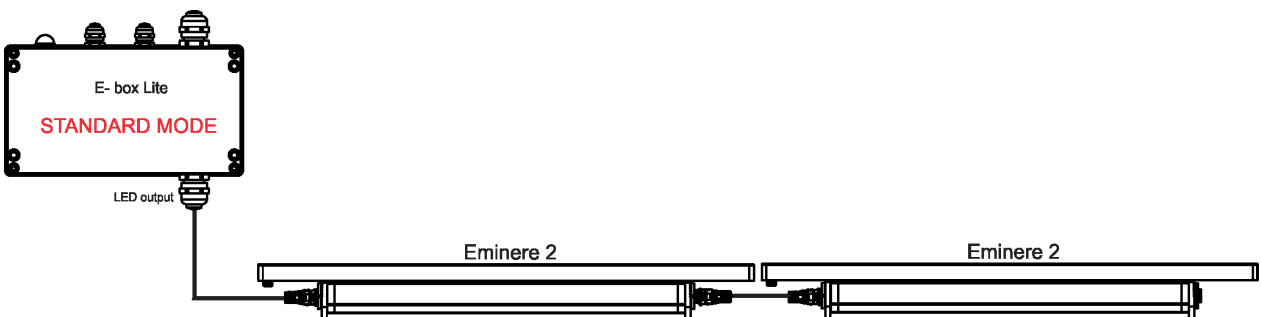

3. Option **“Pass-Thr”** is selected from the menu **“E-box mode”** and LED modules are connected in parallel (it is a typical operating mode for Emineres Inground).

In the first step you have to update connected LED modules by means of the file **Eminere.lib** in the **ROBE Uploader**. In case of combination of Emineres and Calummas XL/L/M/S, after updating Eminere modules update Calumma modules using the file **Calumma.lib**. Only LED modules will be shown in the **ROBE Uploader**. The E-box will not be updated, only connected LED modules.

In the second step you have to set the E-box to the **Standard mode** and switch it off/on. Use the file **EminereEbox.lib** in the **ROBE Uploader** for software update of the E-box. Only E-box will be shown in the **ROBE Uploader**. After updating the E-box, set the E-box to the **Pass-Thorough mode** and switch it off/on.

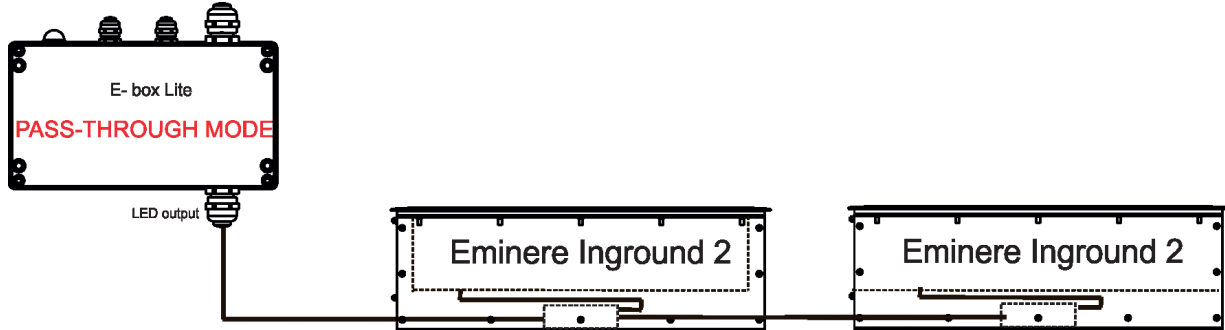

Examples of connections for software update:

1. By means of Ethernet connection

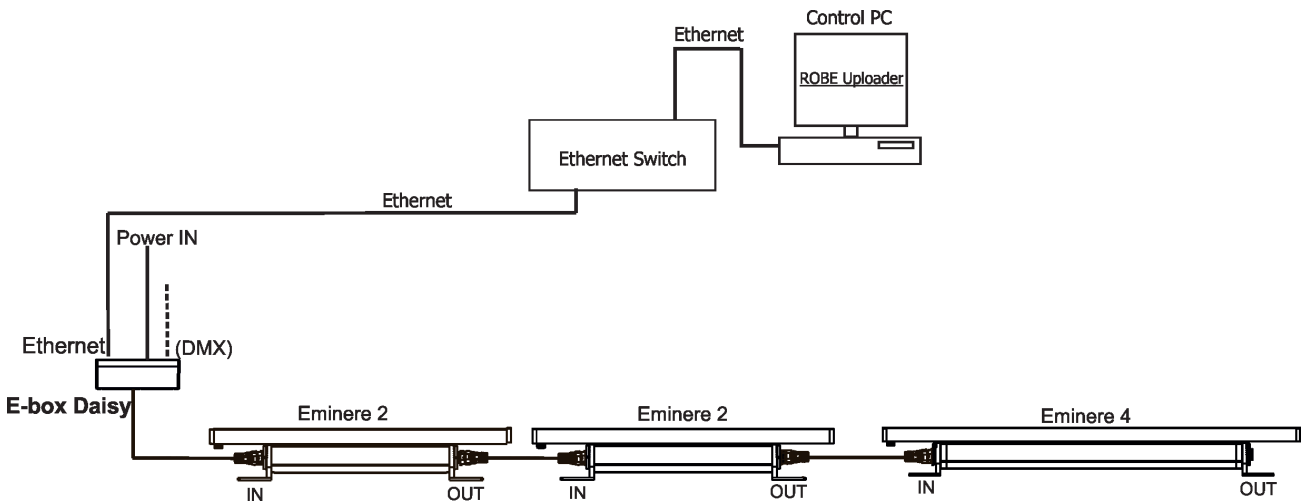

2. By means of DMX connection and the Robe Universal Interface (Robe Universal Interface WTX).

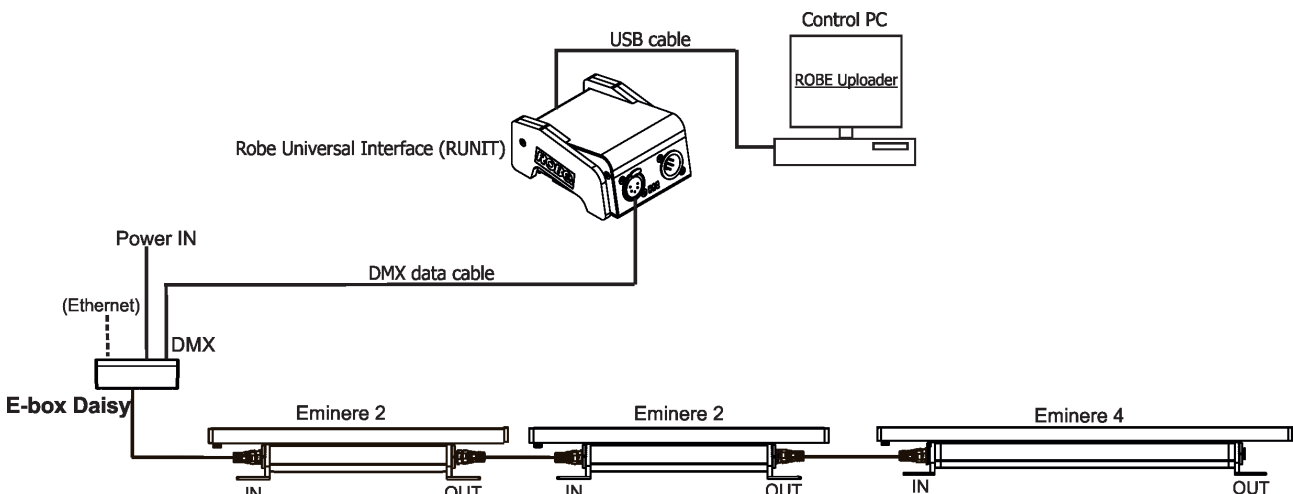

## 8. Technical specifications

### E-box Daisy

Number of inputs:	1
Input voltage	120-277 V AC; 50/60Hz
Power consumption	5W (self-consumption of the E-box)
Fuse	T 0.5A H
LED Output	
Number of outputs	1
Voltage	120-277 V
Max. Current	16A
Control	2-row LCD display & 4 buttons
Supported protocols	USITT DMX 512, ArtNet, sACN, RDM
W-DMX control (optional)	
Connection	
Power IN	terminal block Phoenix 2 SPT_2.5/3-V-5.0
Ethernet IN/OUT	terminal block Phoenix SPTAF_1/9-3.5
DMX IN/OUT	terminal block Phoenix SPTAF 1/3-3,5
LED Output	terminal block Phoenix SPT_2.5/3-V-5.0
Data Output	terminal block Phoenix SPTAF 1/3-3,5
Operating ambient temperature range	-20/+40°C (-4°F / +104°F)
Protection factor	CE: IP67
Weight	2.78 kg (6.13 lbs)

### Dimensions

mm [inch]

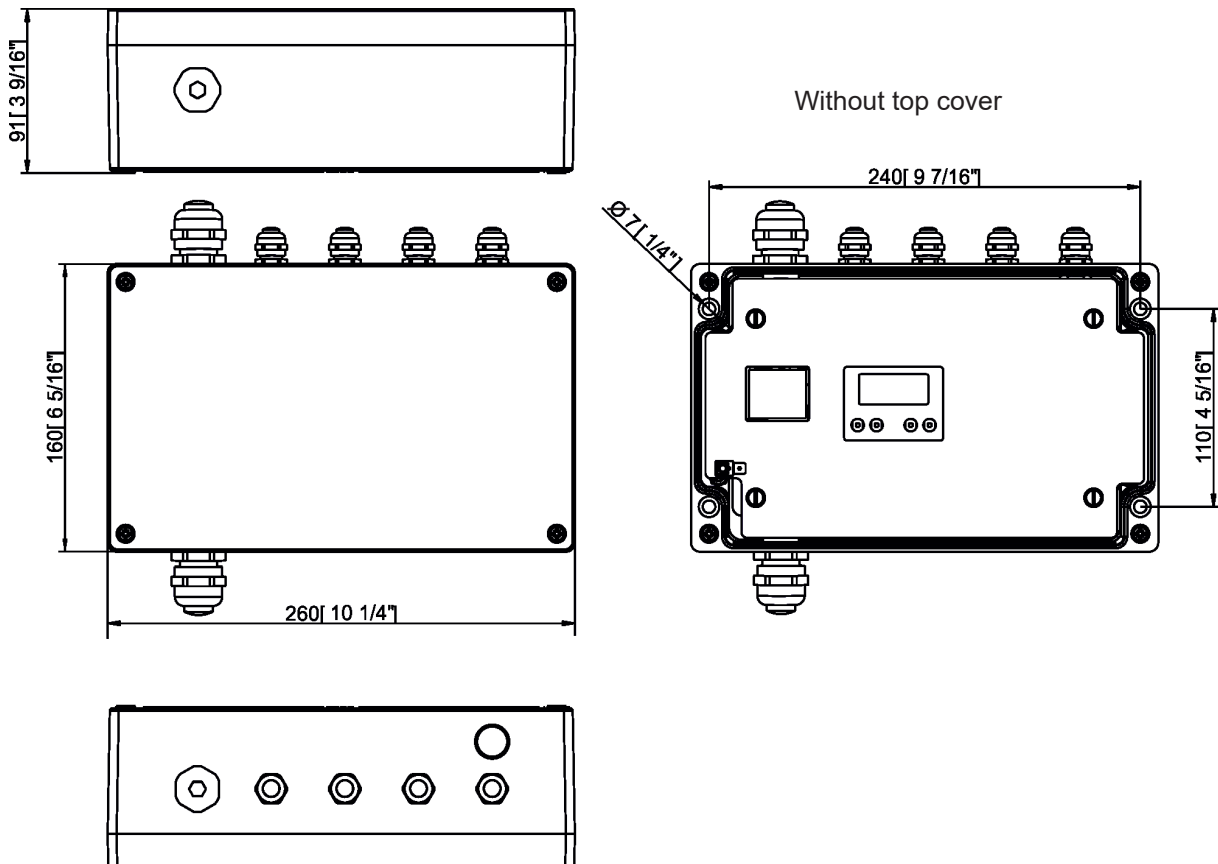

**E-box Star**

Number of inputs:	1
Input voltage	120-277 V AC; 50/60Hz
Power consumption	5W (self-consumption of the E-box)
Fuse	T 0.5A H
LED Outputs	
Number of outputs	6
Voltage	120-277 V each output)
Max. current	16A in total for all outputs
Warning: In view of the fact that e E-box Star has only one power input, outputs to Emineres cannot be so loaded as outputs for Emineres at the E-box Pro.	
Control	2-row LCD display & 4 buttons
Supported protocols	USITT DMX 512, ArtNet, sACN, RDM
W-DMX control (optional)	
Connection	
Power IN	terminal block Phoenix 2 SPT_2.5/3-V-5.0
Ethernet IN/OUT	terminal block Phoenix SPTAF_1/9-3.5
DMX IN/OUT	terminal block Phoenix SPTAF 1/3-3,5
LED Output	terminal block Phoenix SPT_2.5/3-V-5.0
Data Output	terminal block Phoenix SPTAF 1/3-3,5
Operating ambient temperature range:	-20/+40°C (-4°F / +104°F)
Protection factor:	CE: IP67
Weight	4.4 kg (9.7 lbs)

Dimensions  
mm [inch]

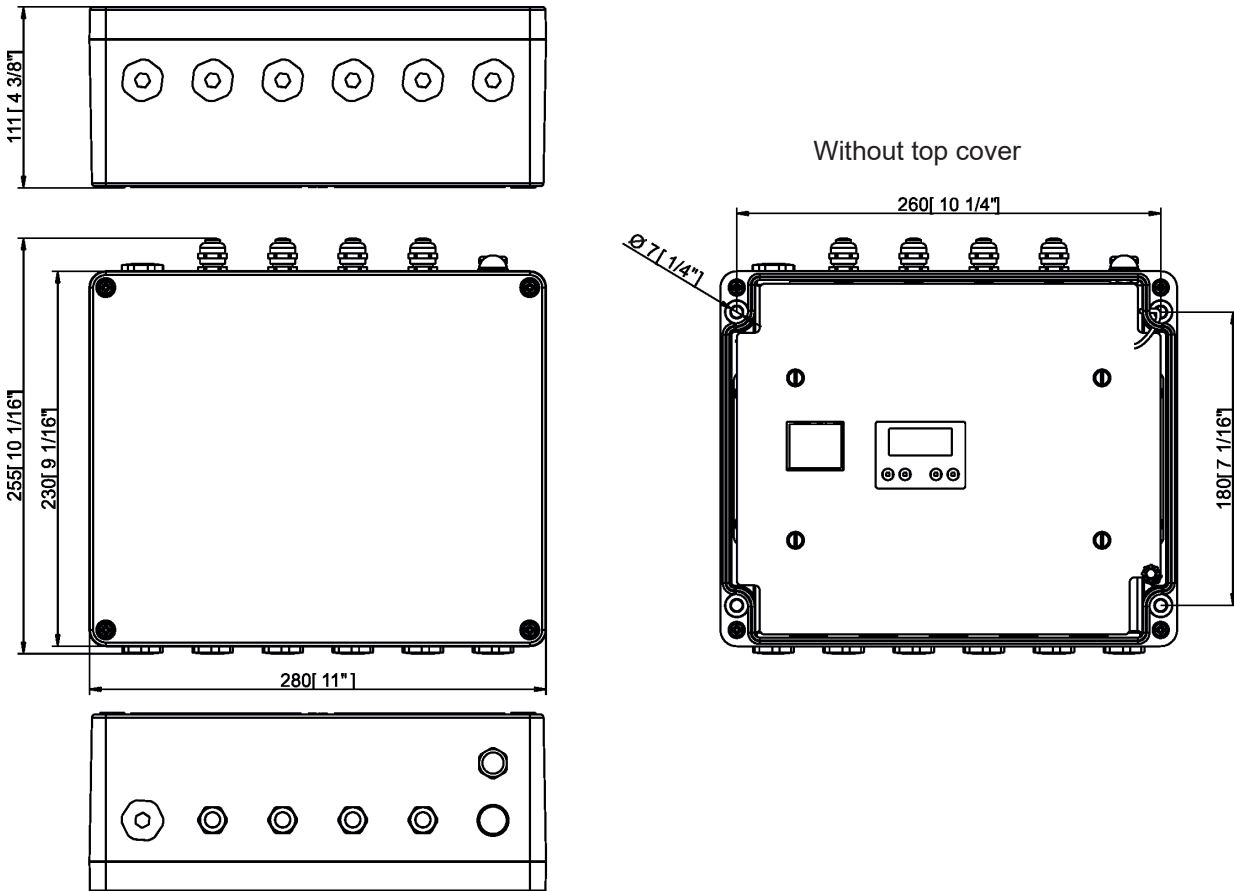

**E-box Lite**

Number of inputs:	1
Input voltage	120-277 V AC; 50/60Hz
Power consumption	5W (self-consumption of the E-box)
Fuse	T 0.5A H
LED Output	
Number of outputs	1
Voltage	120-277 V
Max. current	16A
Control	2-row LCD display & 4 buttons
Supported protocols	USITT DMX 512, RDM
W-DMX control (optional)	
Connection	
Power IN	terminal block Phoenix 2 SPT_2.5/3-V-5.0
DMX IN/OUT	terminal block Phoenix SPTAF 1/3-3,5
LED Output	terminal block Phoenix SPT_2.5/3-V-5.0
Data Output	terminal block Phoenix SPTAF 1/3-3,5
Operating ambient temperature range	-20/+40°C (-4°F / +104°F)
Protection factor	CE: IP67
Weight	1.67 kg (3.85 lbs)

Dimensions  
mm [inch]

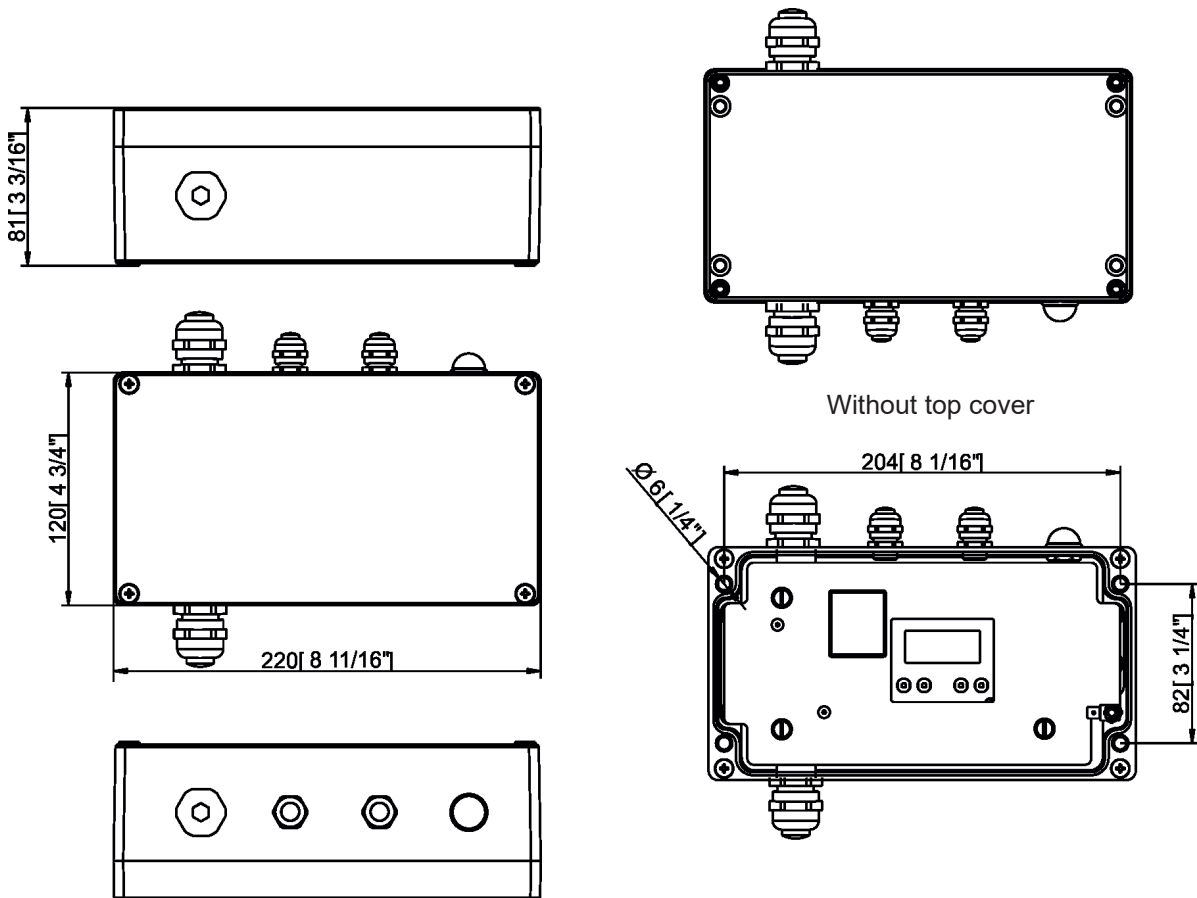

**Included items**

- 1 x E-box
- 1 x User manual

**9. Disposing of the product**

To preserve the environment please dispose or recycle this product at the end of its life according to the local regulations and codes.

**10. ChangeLog**

This section summarizes changes in the user manual.

Version of the manual	Date of issue	Description of changes
1.1	2/10/2019	Changes in menu Personality
1.2	17/10/2019	E-box Light added
1.3	25/11/2019	Booster box added
1.4	11/03/2020	Information about Eminere Inground added
1.5	22/04/2020	Technical specifications more specified
1.6	17/05/2020	Wiring of Emineres changed (Data +, Data -)
1.7	29/05/2020	Pass-Thr mode description added
1.8	22/06/2020	Voltage range change
1.9	25/11/2020	Menu Stand Alone added
2.0	27/05/2021	Menu item Input Data added
2.1	24/09/2021	Pass-Thru mode description changed
2.2	30/09/2021	E-box Pro removed
2.3	19/10/2021	Technical Specifications changed
2.4	10/05/2022	E-box Lite description changed
2.5	08/12/2022	New DMX chart ver. 3.1
2.6	05/01/2023	Description of fixture update changed
2.7	10/02/2023	DMX chart ver. 3.2 (Eminere), DMX chart ver. 1.2 (Calumma), REAP added
2.8	05/03/2024	DMX chart ver. 3.3 (Eminere), DMX chart ver. 1.3 (Calumma), Menu Test program removed
2.9	13/09/2024	Number of fixtures in Standard Mode changed

September 13, 2024

Specifications are subject to change without notice.

Copyright © 2019-2024 Robe Lighting - All rights reserved

Made in CZECH REPUBLIC by ROBE LIGHTING s.r.o. Palackeho 416/20 CZ 75701 Valasske Mezirici



**DMX protocol for: Eminere 1/2/3/4; Eminere Side 1/2/3/4;  
Eminere Inground 2/4; Eminere Remote 1/2/3/4;  
UVinere 2/4; UVinere Remote 1/2/4**

Version: 3.3 (23 modes in total), software version 3.0 and higher

Mode/Channels in all								Mode 1: RGBW(A)-8bit, Mode 2: RGB 8-bit, Mode 3: full RGBW(A)	
1	2	3	4	5	6	7	8-10	Mode 4: White-full control, Mode 5: Reduced RGBW(A)	
4	3	12	3	6	8	15	Reserved	Mode 6- Reduced RGBW(A)+white control	
								Mode 7- full RGBW(A)+virtual colour wheel	
								RGBW(A) / RGB modes	
Mode/channels							DMX Value	Function	Type of control
1	2	3	4	5	6	7			
-	-	-	-	-	-	1	0	<b>Special functions</b> No function	step
								<i>To activate following functions , stop in DMX value for at least 3 sec.</i>	
							1-2	Save current DMX values to fixture as initial DMX values.	step
							3-4	Show saved initial DMX values	step
							5-6	Run factory demo sequences at switching fixture on (without DMX)	step
							7-8	Insect friendly light On (RGBA version only)	step
							9-10	Insect friendly light Off (RGBA version only)	step
							11-255	Reserved	
1	1	1	-	1	1	2	0-255	<b>Red</b> Red LEDs saturation control (0-100%)	proportional
-	-	2	-	-	-	3	0-255	<b>Red Fine</b> Red LEDs saturation control fine	proportional
2	2	3	-	2	2	4	0-255	<b>Green</b> Green LEDs saturation control (0-100%)	proportional
-	-	4	-	-	-	5	0-255	<b>Green Fine</b> Green LEDs saturation control fine	proportional
3	3	5	-	3	3	6	0-255	<b>Blue</b> Blue LEDs saturation control (0-100%)	proportional
-	-	6	-	-	-	7	0-255	<b>Blue Fine</b> Blue LEDs saturation control fine	proportional
4	-	7	-	4	4	8	0-255	<b>White (Amber)</b> White LEDs saturation control (0-100%)	proportional
-	-	8	-	-	-	9	0-255	<b>White (Amber) Fine</b> White LEDs saturation control fine	proportional
-	-	9	1	-	5	10	0	<b>Green correction</b> Uncorrected white	step
							1-127	Minus green --> uncorrected white	proportional
							128	Uncorrected white (128=default)	step
							129-255	Uncorrected white --> Plus green	proportional
-	-	10	2	-	6	11	0	<b>Colour temperature correction (CTC)</b> No function	step
							1-10	Tungsten dimming 2700 K	step
							11-20	Tungsten dimming 3200 K	step
							21-255	Colour temperature changing from 1800 K --> 6500 K	proportional

DMX protocol

Mode/channels							DMX Value	Function	Type of control
1	2	3	4	5	6	7			
								(21-1800K, 66-2700K, 91-3200K,141-4200K, 211-5600K, 255-6500K)	
-	-	-	-	-	-	12		<b>Virtual Colour Wheel</b>	
							0	No function	step
							1-2	White 1800 K	step
							3-4	White 2700 K	step
							5-6	White 3200 K	step
							7-8	White 4200 K	step
							9-10	White 5600 K	step
							11-12	White 6500 K	step
							13	Blue (Blue=full, Red+Green+White/Amber=0)	step
							14-23	Red=0, Green->up,Blue =full, White/Amber=0	proportional
							24	Cyan (Red=0, Green=full, Blue =full, White/Amber=0)	step
							25-34	Red=0, Green=full, Blue->down, White/Amber=0	proportional
							35	Green (Red=0, Green=full, Blue =0, White/Amber=0)	step
							36-45	Red->up, Green=full, Blue=0, White/Amber=0	proportional
							46	Yellow (Red=full, Green=full, Blue=0, White/Amber=0)	step
							47-56	Red=full, Green->down, Blue=0, White/Amber=0	proportional
							57	Red(Red=full, Green=0, Blue=0, White/Amber=0)	step
							58-67	Red=full, Green=0, Blue->up, White/Amber=0	proportional
							68	Magenta (Red=full, Green=0, Blue=full, White/Amber=0)	step
							69-78	Red -> down, Green=0, Blue=full, White/Amber=0	proportional
							79	Blue (Red=0, Green=0, Blue=full, White/Amber=0)	step
								<b>Transition effects</b>	
							80-87	Rainbow effect (with fade time) from slow-> fast	proportional
							88-95	Rainbow effect (without fade time) from slow-> fast	proportional
							96-103	Full dynamic white (1800K->6500K->1800K) (with fade time) from slow-> fast	proportional
							104-111	Full dynamic white (1800K->6500K->1800K) (without fade time) from slow-> fast	proportional
							112-119	Dynamic warm white (1800K-3000K-1800K) (with fade time) from slow-> fast	proportional
							120-127	Dynamic warm white (1800K-3000K-1800K) (without fade time) from slow-> fast	proportional
							128-135	Rainbow effect + full dynamic white (with fade time) from slow-> fast	proportional
							136-143	Rainbow effect + full dynamic white (without fade time) from slow-> fast	proportional
							144-151	Blue/Green effect (with fade time) from slow-> fast	proportional
							152-159	Blue/Green effect (without fade time) from slow-> fast	proportional
							160-167	Red/Blue effect (with fade time) from slow-> fast	proportional
							168-175	Red/Blue effect (without fade time) from slow-> fast	proportional
							176-183	Green/Red effect (with fade time) from slow-> fast	proportional
							184-191	Green/Red effect (without fade time) from slow-> fast	proportional
							192-199	Blue/4000K effect (with fade time) from slow-> fast	proportional
							200-207	Blue/4000K effect (without fade time) from slow-> fast	proportional
							208-215	Green/4000K effect (with fade time) from slow-> fast	proportional
							216-223	Green/4000K effect (without fade time) from slow-> fast	proportional
							224-231	Red/4000K effect (with fade time) from slow-> fast	proportional
							232-239	Red/4000K effect (without fade time) from slow-> fast	proportional
							240-255	Reserved	

DMX protocol

Mode/channels							DMX Value	Function	Type of control
1	2	3	4	5	6	7			
						<b>13</b>		<b>Shutter/Strobe</b>	
							0-31	Shutter closed	step
							32-63	Shutter open	step
							64-95	Strobe-effect from slow to fast	proportional
							96-127	Shutter open	step
							128-143	Opening pulse in sequences from slow to fast	proportional
							144-159	Closing pulse in sequences from fast to slow	proportional
							160-191	Shutter open	step
							192-223	Random strobe-effect from slow to fast	proportional
							224-255	Shutter open	step
-	-	<b>11</b>	<b>3</b>	<b>5</b>	<b>7</b>	<b>14</b>		<b>Dimmer</b>	
							0-255	Light intensity coarse (0-100%)	proportional
-	-	<b>12</b>	-	<b>6</b>	<b>8</b>	<b>15</b>		<b>Dimmer Fine</b>	
							0-255	Light intensity fine	proportional
Copyright © 2022-2024 Robe Lighting s.r.o. - All rights reserved									
All Specifications subject to change without notice									

DMX protocol for: Eminere 1/2/3/4; Eminere Side 1/2/3/4; Eminere Inground 2/4; Eminere Remote 1/2/3/4; UVinere 2/4; UVinere Remote 1/2/4					
Version: 3.3 (23 modes in total)					
<b>Mode/Channels in all</b>				Mode 11: White selection, Mode 12: WW + CW	
<b>11</b>	<b>12</b>	<b>13</b>	<b>14-16</b>	Mode 13: Only dimmer	
3	4	2	Reserved	<i>Mode 13 is suitable for UVinere and UVinere Remote</i>	
<b>TW and PW modes</b>					
Mode/channels			DMX Value	Function	Type of control
11	12	13			
1	-	-	0 - 255	<b>White colour selection</b> White from 2700 K - 6500 K	proportional
-	1	-	0 - 255	<b>Warm White</b> Warm White LEDs saturation control (0-100%)	proportional
-	2	-	0 - 255	<b>Cool White</b> Cool White LEDs saturation control (0-100%)	proportional
2	3	1	0 - 255	<b>Dimmer</b> Light intensity coarse (0 - 100%)	proportional
3	4	2	0 - 255	<b>Dimmer Fine</b> Light intensity fine	proportional
Copyright © 2022-2024 Robe Lighting s.r.o. - All rights reserved					
All Specifications subject to change without notice					

**DMX protocol for: Eminere 1/2/3/4; Eminere Side 1/2/3/4;  
Eminere Inground 2/4; Eminere Remote 1/2/3/4;**

Version: 3.3 (23 modes in total)

Mode/Channels in all					Mode 17: RGBW(A) pixels, Mode 18: RGB pixels, Mode 19: TW pixels,		
17	18	19	20	21-23	Mode 20: PW dimmer pixels		
16	12	8	8	Reserved			
Mode/channels					DMX Value	Function	Type of control
17	18	19	20				
1	1	-	-	0 - 255	<b>Red 1 -Eminere 1/2/3/4</b> Red LEDs saturation control (0-100%)	proportional	
2	2	-	-	0 - 255	<b>Green 1-Eminere 1/2/3/4</b> Green LEDs saturation control (0-100%)	proportional	
3	3	-	-	0 - 255	<b>Blue 1-Eminere 1/2/3/4</b> Blue LEDs saturation control (0-100%)	proportional	
4	-	-	-	0 - 255	<b>White (Amber) 1-Eminere 1/2/3/4</b> White LEDs saturation control (0-100%)	proportional	
5	4	-	-	0 - 255	<b>Red 2 -Eminere 2/3/4</b> Red LEDs saturation control (0-100%)	proportional	
6	5	-	-	0 - 255	<b>Green 2-Eminere 2/3/4</b> Green LEDs saturation control (0-100%)	proportional	
7	6	-	-	0 - 255	<b>Blue 2-Eminere 2/3/4</b> Red LEDs saturation control (0-100%)	proportional	
8	-	-	-	0 - 255	<b>White (Amber) 2-Eminere 2/3/4</b> White LEDs saturation control (0-100%)	proportional	
9	7	-	-	0 - 255	<b>Red 3-Eminere 3/4</b> Red LEDs saturation control (0-100%)	proportional	
10	8	-	-	0 - 255	<b>Green 3-Eminere 3/4</b> Green LEDs saturation control (0-100%)	proportional	
11	9	-	-	0 - 255	<b>Blue 3-Eminere 3/4</b> Blue LEDs saturation control (0-100%)	proportional	
12	-	-	-	0 - 255	<b>White (Amber) 3-Eminere 3/4</b> White LEDs saturation control (0-100%)	proportional	
13	10	-	-	0 - 255	<b>Red 4-Eminere 4</b> Red LEDs saturation control (0-100%)	proportional	
14	11	-	-	0 - 255	<b>Green 4-Eminere 4</b> Green LEDs saturation control (0-100%)	proportional	
15	12	-	-	0 - 255	<b>Blue 4-Eminere 4</b> Blue LEDs saturation control (0-100%)	proportional	
16	-	-	-	0 - 255	<b>White (Amber) 4 -Eminere 4</b> White LEDs saturation control (0-100%)	proportional	
-	-	1	-		<b>Warm White 1 -Eminere 1/2/3/4</b> Warm White LEDs saturation control (0-100%)	proportional	
-	-	2	-	0 - 255	<b>Cool White 1-Eminere 1/2/3/4</b> Cool White LEDs saturation control (0-100%)	proportional	
-	-	3	-		<b>Warm White 2-Eminere 2/3/4</b>		

DMX protocol

Mode/channels				DMX Value	Function	Type of control
17	18	19	20			
				0 - 255	Warm White LEDs saturation control (0-100%)	proportional
-	-	4	-	0 - 255	<b>Cool White 2-Eminere 2/3/4</b> Cool White LEDs saturation control (0-100%)	proportional
-	-	5	-	0 - 255	<b>Warm White 3-Eminere 3/4</b> Warm White LEDs saturation control (0-100%)	proportional
-	-	6	-	0 - 255	<b>Cool White 3-Eminere 3/4</b> Cool White LEDs saturation control (0-100%)	proportional
-	-	7	-	0 - 255	<b>Warm White 4 -Eminere 4</b> Warm White LEDs saturation control (0-100%)	proportional
-	-	8	-	0 - 255	<b>Cool White 4 -Eminere 4</b> Cool White LEDs saturation control (0-100%)	proportional
-	-	-	1	0 - 255	<b>Dimmer 1</b> Light intensity coarse (0 - 100%)	proportional
-	-	-	2	0 - 255	<b>Dimmer Fine 1</b> Light intensity fine	proportional
-	-	-	3	0 - 255	<b>Dimmer 2</b> Light intensity coarse (0 - 100%)	proportional
-	-	-	4	0 - 255	<b>Dimmer Fine 2</b> Light intensity fine	proportional
-	-	-	5	0 - 255	<b>Dimmer 3</b> Light intensity coarse (0 - 100%)	proportional
-	-	-	6	0 - 255	<b>Dimmer Fine 3</b> Light intensity fine	proportional
-	-	-	7	0 - 255	<b>Dimmer 4</b> Light intensity coarse (0 - 100%)	proportional
-	-	-	8	0 - 255	<b>Dimmer Fine 4</b> Light intensity fine	proportional
Copyright © 2022-2024 Robe Lighting s.r.o. - All rights reserved						
All Specifications subject to change without notice						

## DMX protocol for Calumma - All sizes - MC and SC

Version: 1.3 (16 modes in total)

Mode/Channels in all								Mode 1- RGBW(A)-8bit, Mode 2- RGB 8-bit, Mode 3- full RGBW(A)	
1	2	3	4	5	6	7	8-10	Mode 4- White-full control, Mode 5- Reduced RGBW(A)	
4	3	12	3	6	8	15	Reserved	Mode 6- Reduced RGBW(A)+white control, Mode 7- Full control	
								Mode 7-Full RGBW(A)+virt. Colour wheel	
								RGBW/RGBA/RGB modes	
Mode/channels							DMX Value	Function	Type of control
1	2	3	4	5	6	7			
-	-	-	-	-	-	1		<b>Special functions</b>	
							0	No function <i>To activate following functions , stop in DMX value for at least 3 sec.</i>	step
							1-2	Save current DMX values to fixture as initial DMX values.	step
							3-4	Show saved initial DMX values	step
							5-6	Run factory demo sequences at switching fixture on (without DMX)	step
							7-8	Insect friendly light On (RGBA version only)	step
							9-10	Insect friendly light Off (RGBA version only)	step
							11-255	Reserved	
1	1	1	-	1	1	2		<b>Red</b>	
							0 - 255	Red LEDs saturation control (0-100%)	proportional
-	-	2	-	-	-	3		<b>Red Fine</b>	
							0 - 255	Red LEDs saturation control fine	proportional
2	2	3	-	2	2	4		<b>Green</b>	
							0 - 255	Green LEDs saturation control (0-100%)	proportional
-	-	4	-	-	-	5		<b>Green Fine</b>	
							0 - 255	Green LEDs saturation control fine	proportional
3	3	5	-	3	3	6		<b>Blue</b>	
							0 - 255	Blue LEDs saturation control (0-100%)	proportional
-	-	6	-	-	-	7		<b>Blue Fine</b>	
							0 - 255	Blue LEDs saturation control fine	proportional
4	-	7	-	4	4	8		<b>White (Amber)</b>	
							0 - 255	White LEDs saturation control (0-100%)	proportional
-	-	8	-	-	-	9		<b>White (Amber) Fine</b>	
							0 - 255	White LEDs saturation control fine	proportional
-	-	9	1	-	5	10		<b>Green correction</b>	
							0	Uncorrected white	step
							1-127	Minus green - uncorrected white	proportional
							128	Uncorrected white (128=default)	step
							129-255	Uncorrected white - Plus green	proportional
-	-	10	2	-	6	11		<b>Colour temperature correction (CTC)</b>	
							0	No function	step
							1 - 10	Tungsten dimming 2700 K	step
							11 - 20	Tungsten dimming 3200 K	step
							21-255	Colour temperature changing from 1800 K --> 6500 K (21-1800K, 66-2700K, 91-3200K,141-4200K, 211-5600K, 255-6500K)	proportional
-	-	-	-	-	-	12		<b>Virtual Colour Wheel</b>	
							0	No function	step

DMX protocol

Mode/channels							DMX Value	Function	Type of control
1	2	3	4	5	6	7			
							1-2	White 1800 K	step
							3-4	White 2700 K	step
							5-6	White 3200 K	step
							7-8	White 4200 K	step
							9-10	White 5600 K	step
							11-12	White 6500 K	step
							13	Blue (Blue=full, Red+Green+White/Amber=0)	step
							14-23	Red=0, Green->up,Blue =full, White/Amber=0	proportional
							24	Cyan (Red=0, Green=full, Blue =full, White/Amber=0)	step
							25-34	Red=0, Green=full, Blue->down, White/Amber=0	proportional
							35	Green (Red=0, Green=full, Blue =0, White/Amber=0)	step
							36-45	Red->up, Green=full, Blue=0, White/Amber=0	proportional
							46	Yellow (Red=full, Green=full, Blue=0, White/Amber=0)	step
							47-56	Red=full, Green->down, Blue=0, White/Amber=0	proportional
							57	Red(Red=full, Green=0, Blue=0, White/Amber=0)	step
							58-67	Red=full, Green=0, Blue->up, White/Amber=0	proportional
							68	Magenta (Red=full, Green=0, Blue=full, White/Amber=0)	step
							69-78	Red -> down, Green=0, Blue=full, White/Amber=0	proportional
							79	Blue (Red=0, Green=0, Blue=full, White/Amber=0)	step
								<b>Transition effects</b>	
							80-87	Rainbow effect (with fade time) from slow-> fast	proportional
							88-95	Rainbow effect (without fade time) from slow-> fast	proportional
							96-103	Full dynamic white (1800K->6500K->1800K) (with fade time) from slow-> fast	proportional
							104-111	Full dynamic white (1800K->6500K->1800K) (without fade time) from slow-> fast	proportional
							112-119	Dynamic warm white (1800K-3000K-1800K) (with fade time) from slow-> fast	proportional
							120-127	Dynamic warm white (1800K-3000K-1800K) (without fade time) from slow-> fast	proportional
							128-135	Rainbow effect + full dynamic white (with fade time) from slow-> fast	proportional
							136-143	Rainbow effect + full dynamic white (without fade time) from slow-> fast	proportional
							144-151	Blue/Green effect (with fade time) from slow-> fast	proportional
							152-159	Blue/Green effect (without fade time) from slow-> fast	proportional
							160-167	Red/Blue effect (with fade time) from slow-> fast	proportional
							168-175	Red/Blue effect (without fade time) from slow-> fast	proportional
							176-183	Green/Red effect (with fade time) from slow-> fast	proportional
							184-191	Green/Red effect (without fade time) from slow-> fast	proportional
							192-199	Blue/4000K effect (with fade time) from slow-> fast	proportional
							200-207	Blue/4000K effect (without fade time) from slow-> fast	proportional
							208-215	Green/4000K effect (with fade time) from slow-> fast	proportional
							216-223	Green/4000K effect (without fade time) from slow-> fast	proportional
							224-231	Red/4000K effect (with fade time) from slow-> fast	proportional
							232-239	Red/4000K effect (without fade time) from slow-> fast	proportional
						<b>13</b>		<b>Shutter/Strobe</b>	
							0-31	Shutter closed	step
							32-63	Shutter open	step
							64-95	Strobe-effect from slow to fast	proportional



DMX protocol

Mode/channels							DMX Value	Function	Type of control
1	2	3	4	5	6	7			
							96-127	Shutter open	step
							128-143	Opening pulse in sequences from slow to fast	proportional
							144-159	Closing pulse in sequences from fast to slow	proportional
							160-191	Shutter open	step
							192-223	Random strobe-effect from slow to fast	proportional
							224-255	Shutter open	step
-	-	11	3	5	7	14		<b>Dimmer</b>	
							0 - 255	Light intensity coarse (0-100%)	proportional
-	-	12	-	6	8	15		<b>Dimmer Fine</b>	
							0 - 255	Light intensity fine	proportional
Copyright © 2022-2024 Robe Lighting s.r.o. - All rights reserved									
All Specifications subject to change without notice									

<b>DMX protocol for Calumma - All sizes - MC and SC</b>					
Version: 1.3 (16 modes in total)					
<b>Mode/Channels in all</b>				<b>TW Modes: Mode 11- White selection + Dimmer, Mode 12- WW + CW</b>	
<b>11</b>	<b>12</b>	<b>13</b>	<b>14-16</b>	<b>PW Mode: Mode 13- Dimmer</b>	
3	4	2	Reserved		
<b>TW and PW modes</b>					
<b>Mode/channels</b>			<b>DMX Value</b>	<b>Function</b>	<b>Type of control</b>
<b>11</b>	<b>12</b>	<b>13</b>			
<b>1</b>	-	-	0 - 255	<b>White colour selection</b> White from 2700 K - 6500 K	proportional
-	<b>1</b>	-	0 - 255	<b>Warm White</b> Warm White LEDs saturation control (0-100%)	proportional
-	<b>2</b>	-	0 - 255	<b>Cool White</b> Cool White LEDs saturation control (0-100%)	proportional
<b>2</b>	<b>3</b>	<b>1</b>	0 - 255	<b>Dimmer</b> Light intensity coarse (0 - 100%)	proportional
<b>3</b>	<b>4</b>	<b>2</b>	0 - 255	<b>Dimmer Fine</b> Light intensity fine	proportional
Copyright © 2022-2024 Robe Lighting s.r.o. - All rights reserved					
All Specifications subject to change without notice					