

Ambiane®  
series

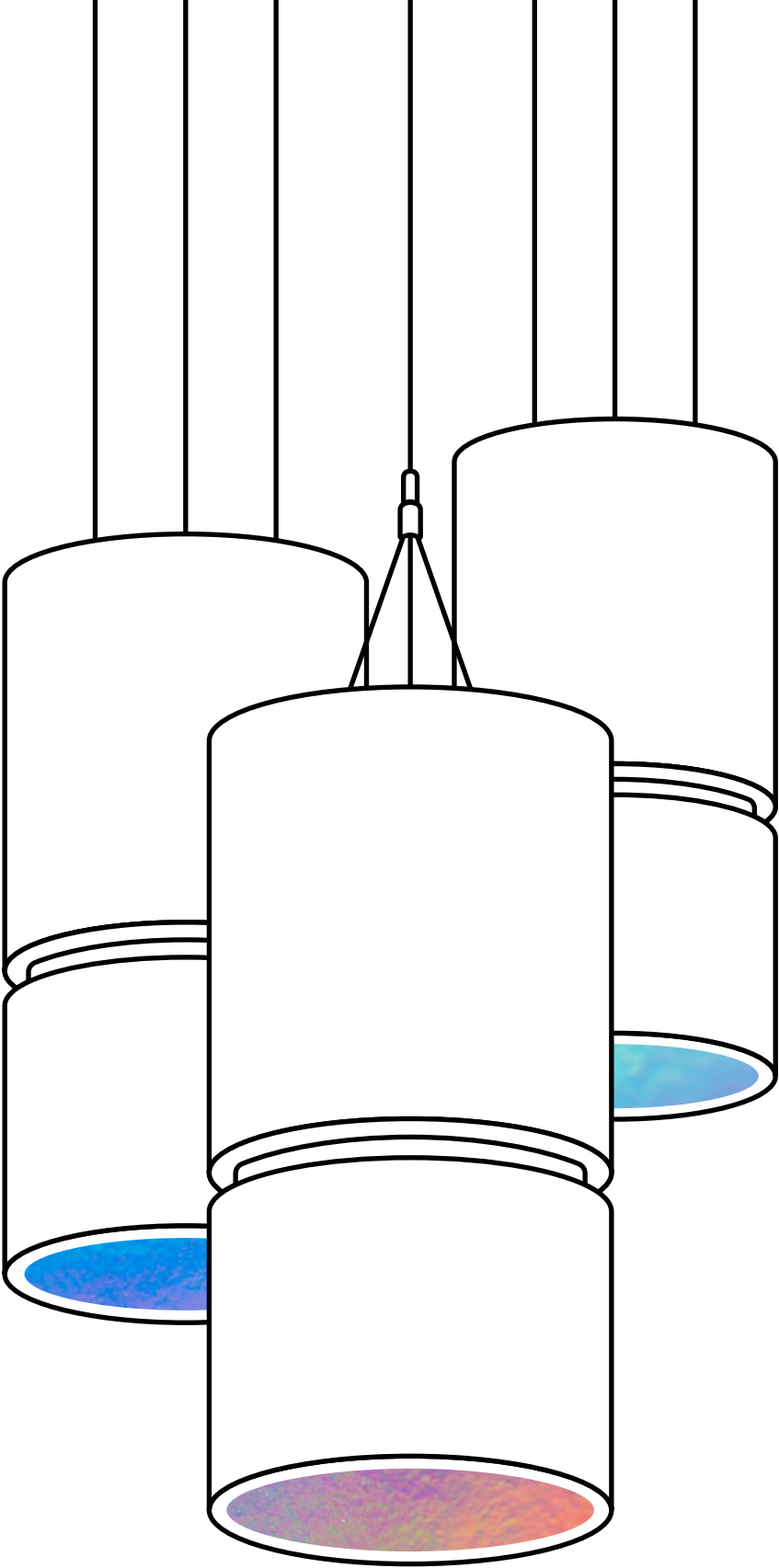

# Ambiane<sup>®</sup> series by Anolis<sup>®</sup>

Anolis designs and manufactures the highest quality LED architectural lighting. All products are designed in our state-of-the-art R&D facility by industry experts. Our fixtures are extensively tested to ensure they perform perfectly in the environment for which they were designed. Utilisation of the latest LED technology ensures low power consumption and long lumen maintenance intervals.

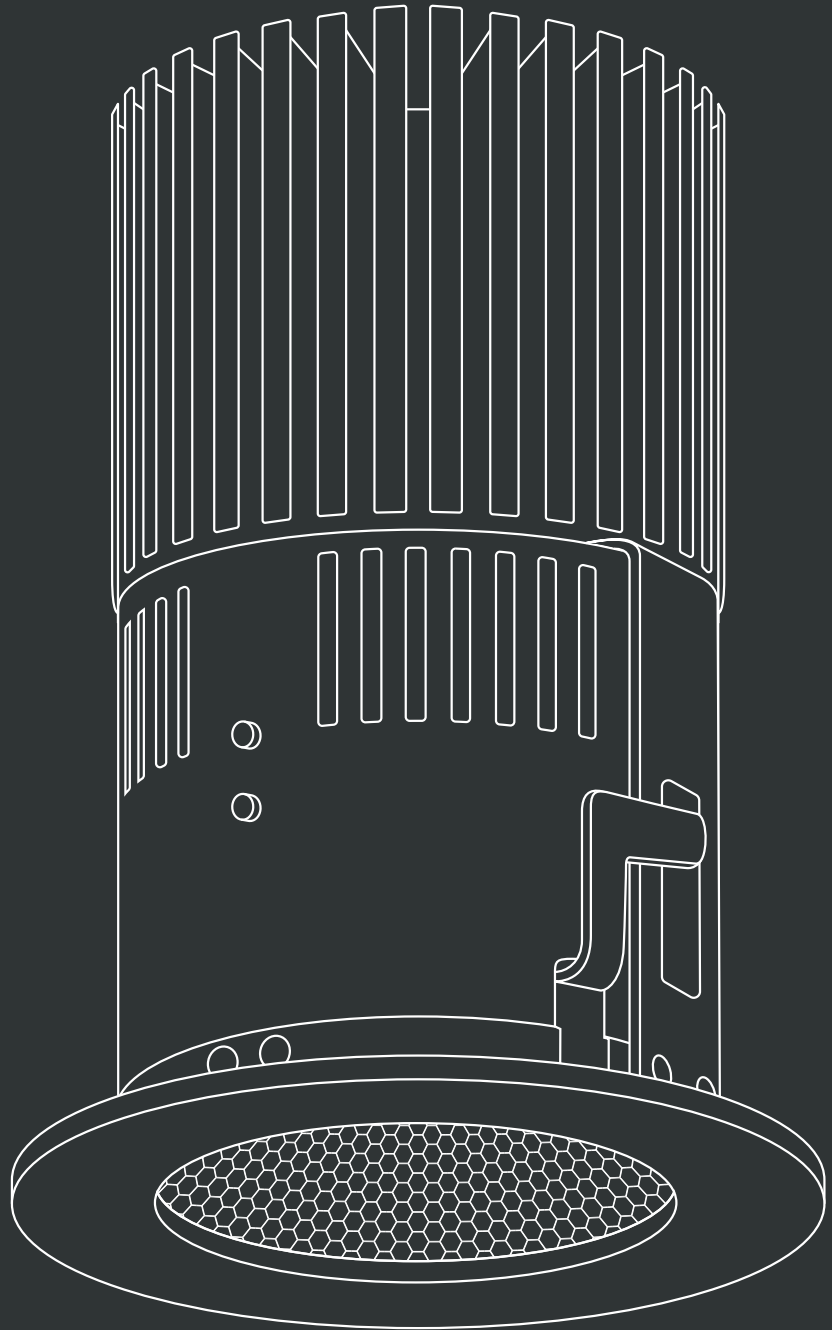

# Content

About	6
Design	10
Selections	14
Optical Design	18
Application Flexibility	22
Mounting Options	26
Products	28



# Ambiane® series



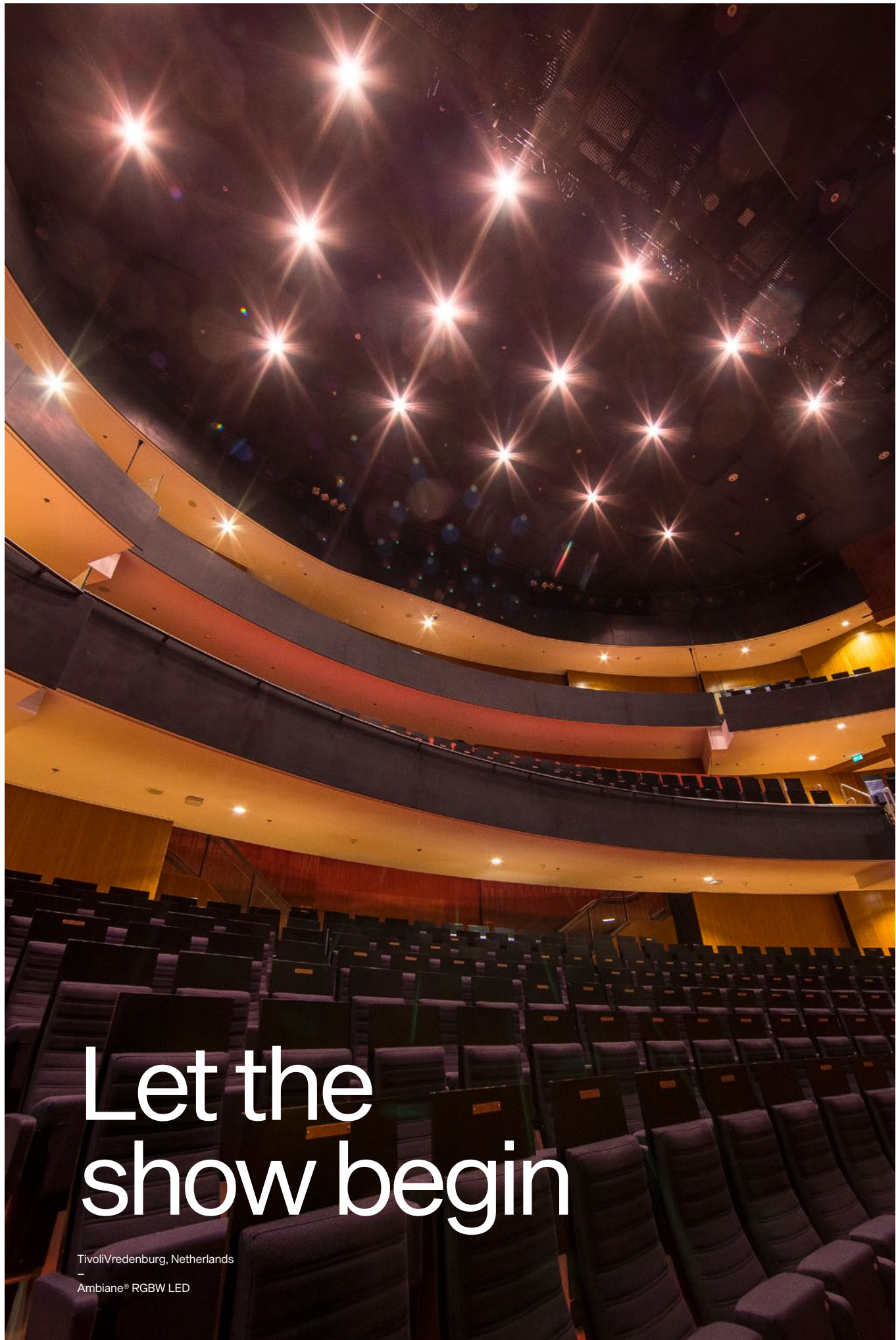

# Let the show begin

TivoliVredenburg, Netherlands

Ambiane® RGBW LED



# with right emotions

The Ambiane series is an architectural lighting range that provides the highest quality of illumination. From recessed to surface mount and pendant mounting location, the variability of the range is ideal for auditoriums, houses of worship, entertainment studios, museums, art galleries, conference rooms, and hotel foyers and ballrooms. Offering the highest optical performance, easy control, and mounting flexibility, the Ambiane series was built to cover long, medium, and short throw applications.



TivoliVredenburg, Netherlands  
—  
Ambiane® RGBW LED

The TivoliVredenburg in central Utrecht, The Netherlands, features seven different music performance spaces and recently had its house and public area lighting upgraded with Anolis Ambiane RGBW LED luminaires.

# Design

Anolis luminaires are developed with an emphasis on performance, flexibility, longevity, control, and last but not least, design ingenuity. Recessed versions of Ambiane seamlessly fit into false-ceiling installations, while pendant versions complement the spacious interior of larger spaces. Its carefully chosen materials, smooth connections and edges, and multiple colour finish options, make Ambiane an ideal lighting solution for interior installations.



The image shows a modern interior space, likely a gallery or museum. The ceiling is a prominent feature, composed of large, light-colored panels arranged in a complex, geometric pattern of overlapping triangles and diamonds. Several recessed square lights are embedded in the ceiling, and three large, black, cylindrical pendant lights hang from it. The walls are illuminated with a soft, purple light, and a row of rectangular panels with a grid-like pattern is visible along the bottom edge. The overall atmosphere is clean, minimalist, and contemporary.

Aesthetically

# pleasing

Anolis luminaires are developed with an emphasis on performance, flexibility, longevity, control, and last but not least, design ingenuity. Recessed versions of Ambiane seamlessly fit into false-ceiling installations, while pendant versions complement the spacious interior of larger spaces. Its carefully chosen materials, smooth connections edges, and multiple colour finish options, make Ambiane an ideal lighting solution for interior installations.



# Selections

## Light Colours



## Colour Temperature

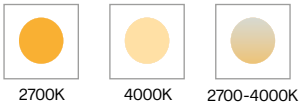

## Trim Finish Options for Recessed versions

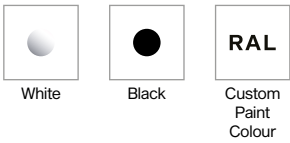

## Finish Options for Pendant & Surface Mount versions

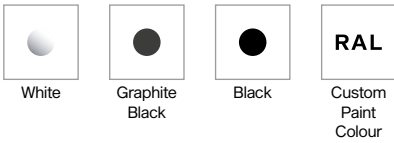

## Standard & Specification



## Fixture Control



5 Year  
Warranty  
(Registered)

## Ambiane XP56 Optic Options

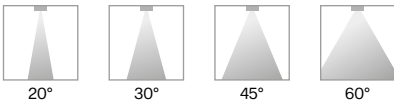

## Ambiane HP111 & MP111 Optic Options

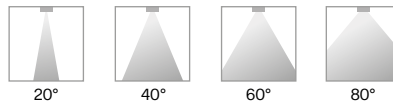

## Ambiane AP Optic Options

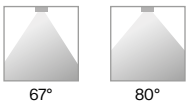

## Ambiane SP16 Optic Options

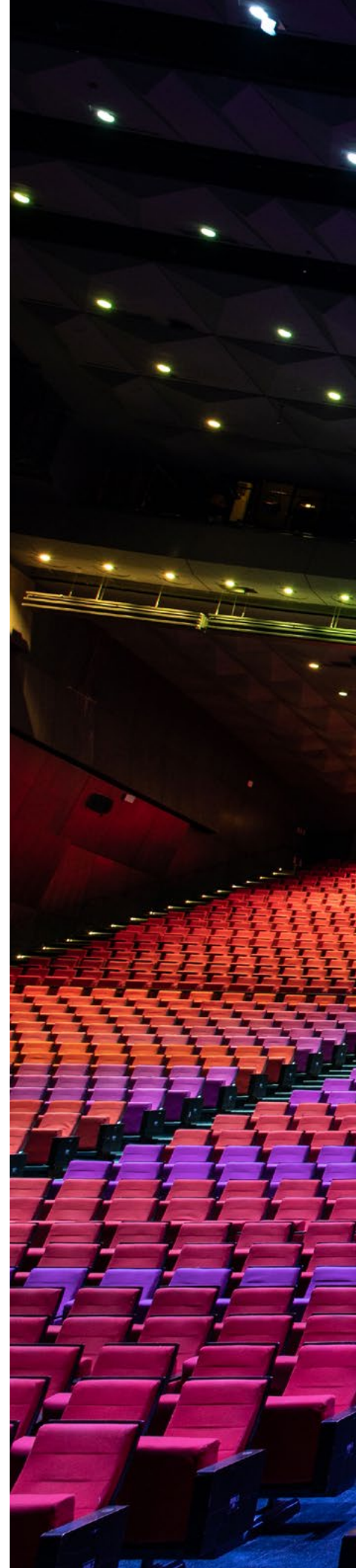
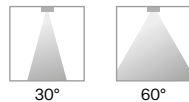





Ambiane® SP16 | 79 × 100–110 mm  
Recessed

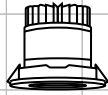

Ambiane® SP16 | 115 × 100–110 mm  
Recessed Tilt

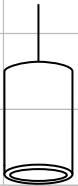

Ambiane® SP16 | 90 × 142 mm  
Pendant Remote



Ambiane® SP16 | 90 × 154 mm  
Surface Mount



Ambiane® SP16 | 90 × 194 mm  
Surface Mount  
Tilt

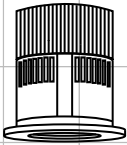

Ambiane® MP111 | 160 × 144–174 mm  
Recessed

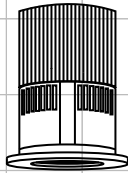

Ambiane® HP111 | 160 × 194–224 mm  
Recessed

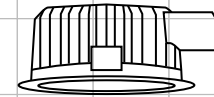

Ambiane® AP | 116 × 266 mm

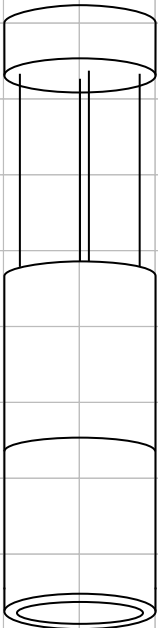

Ambiane® XP56 | 202 × 455 mm  
Pendant

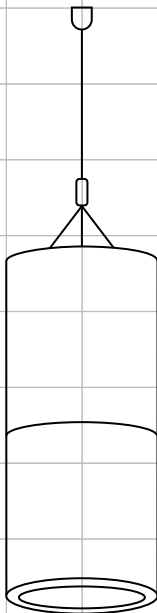

Ambiane® XP56 | 202 × 455 mm  
Pendant Remote

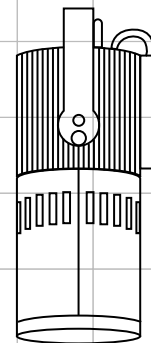

Ambiane® XP56 | 197 × 443 mm  
Recessed



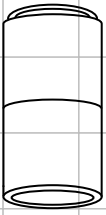

Ambiane® MP111 | 129 × 241–271 mm  
Surface Mount

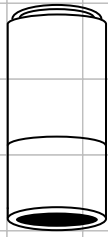

Ambiane® HP111 | 129 × 271–302 mm  
Surface Mount

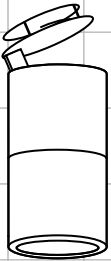

Ambiane® MP111 | 129 × 331–365 mm  
Surface Mount  
Tilt

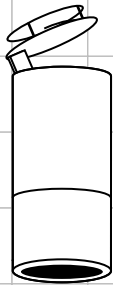

Ambiane® HP111 | 129 × 361–395 mm  
Surface Mount  
Tilt



Ambiane® MP111 | 129 × 241–271 mm  
Pendant Remote



Ambiane® HP111 | 129 × 268–302 mm  
Pendant Remote

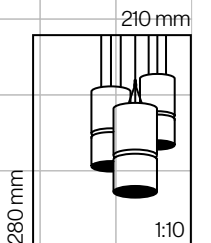
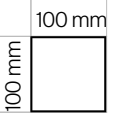

# Optical Performance

Ambiane series luminaires are accommodated with a top-quality LED module and full spectrum LED selection offering five different colour variants. Its green colour correction is extremely useful for lighting for video, when balancing multiple light sources, and the CCT control allows you to define various white temperatures. The Tungsten Dim version is equipped with additional amber, lime and white LEDs for full spectrum coverage with a CRI 90+. An intelligent power balancing system and finely matched and calibrated LEDs are a must to provide the best optical performance to meet the highest standards.

Ambiane SP16

30°  
350 lm



60°  
365 lm



Ambiane HP111

20°  
2289 lm



40°  
3024 lm



60°  
3239 lm



80°  
3145 lm



Ambiane AP

67°  
2713 lm



80°  
2495 lm



Ambiane MP111

20°  
1559 lm



40°  
2060 lm



60°  
2206 lm



80°  
2142 lm



Ambiane XP56

20°  
7344 lm



30°  
8707 lm



45°  
8865 lm



60°  
10 107 lm



# Colour Mixing

The Ambiane series offers a full spectrum of colours with thoughtfully chosen LEDs using the latest technology standard and colour calibration. Precisely designed mixing chambers provide super-smooth colour mixing capabilities to deliver perfectly homogenized colours without light spills and with various beam angles. Traditional Tungsten Dim for warm comforting glow and Low Light Linearity (L3™) 18-bit control for seamless fades-to-black, even when mixed with traditional sources. Low glare reflectors are designed to have very low UGR values for a comfortable visual experience. Optical accessories complement all of these features and adjust the light output depending on requirements.

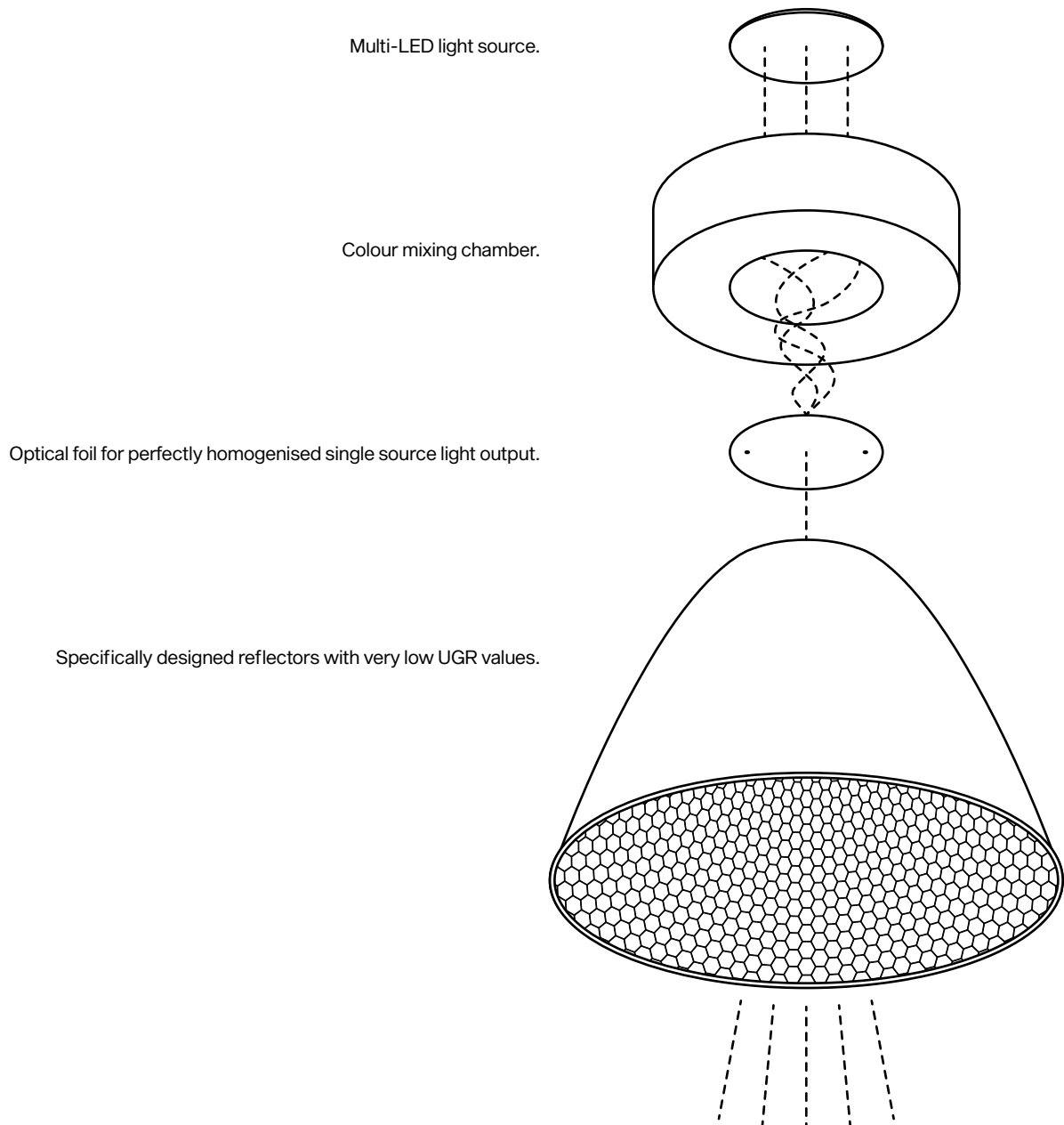

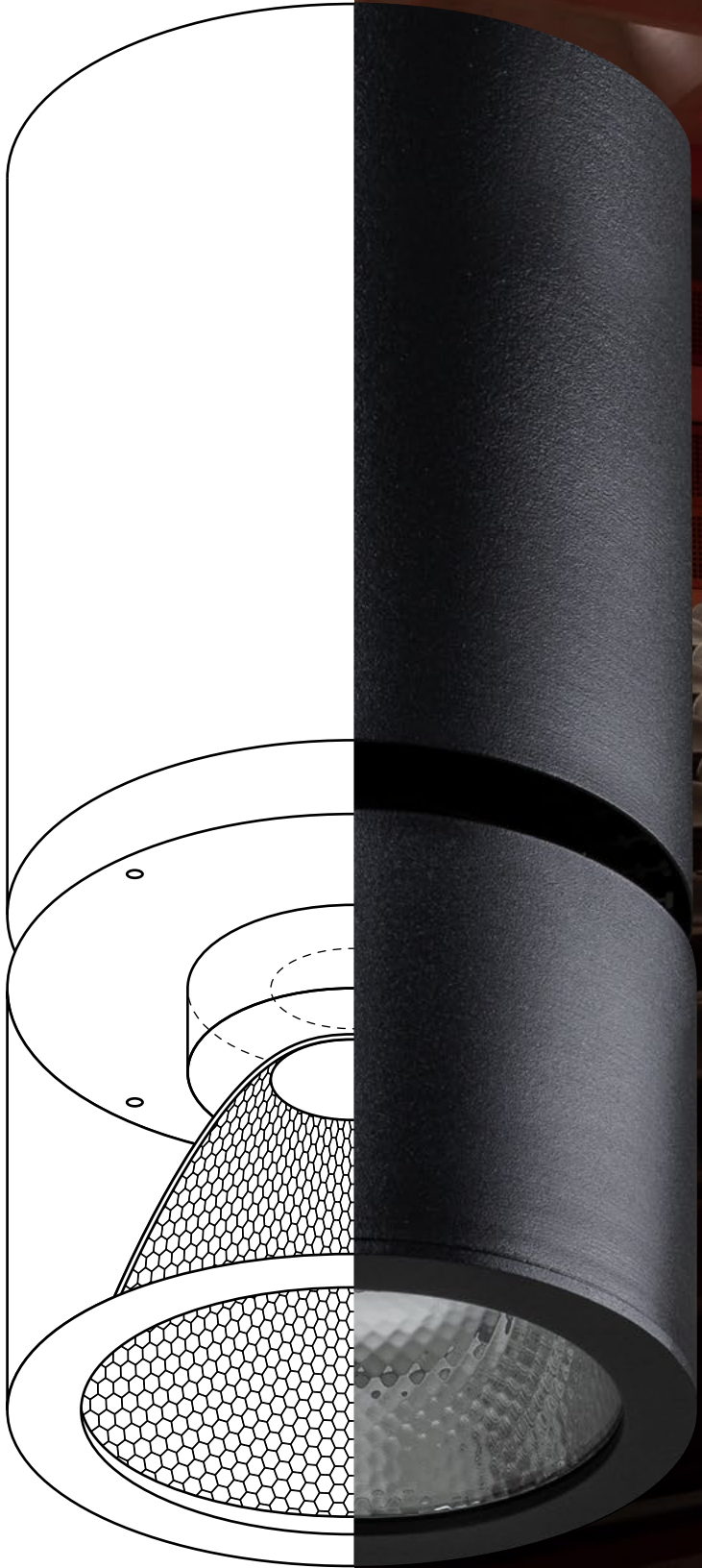

# Application Flexibility

Ambiane fixtures are thoughtfully made to meet the mounting requirements of any application with recessed fixtures for a false-ceiling mount and a pendant solution for flat or sloping ceilings. Using an integrated or remote power supply, with wireless option available, choose from Ambiane SP, AP, HP or XP models to cover long, medium and short throw applications, while keeping the quality of illumination at its highest. Lighting designers can create ambient lighting and accent lighting of the right mood thanks to the different beam angles and colour options available. The fanless design allows for a silent performance while the secondary power input secures back-up lighting, all backed by a 5-year warranty for the most demanding installations.

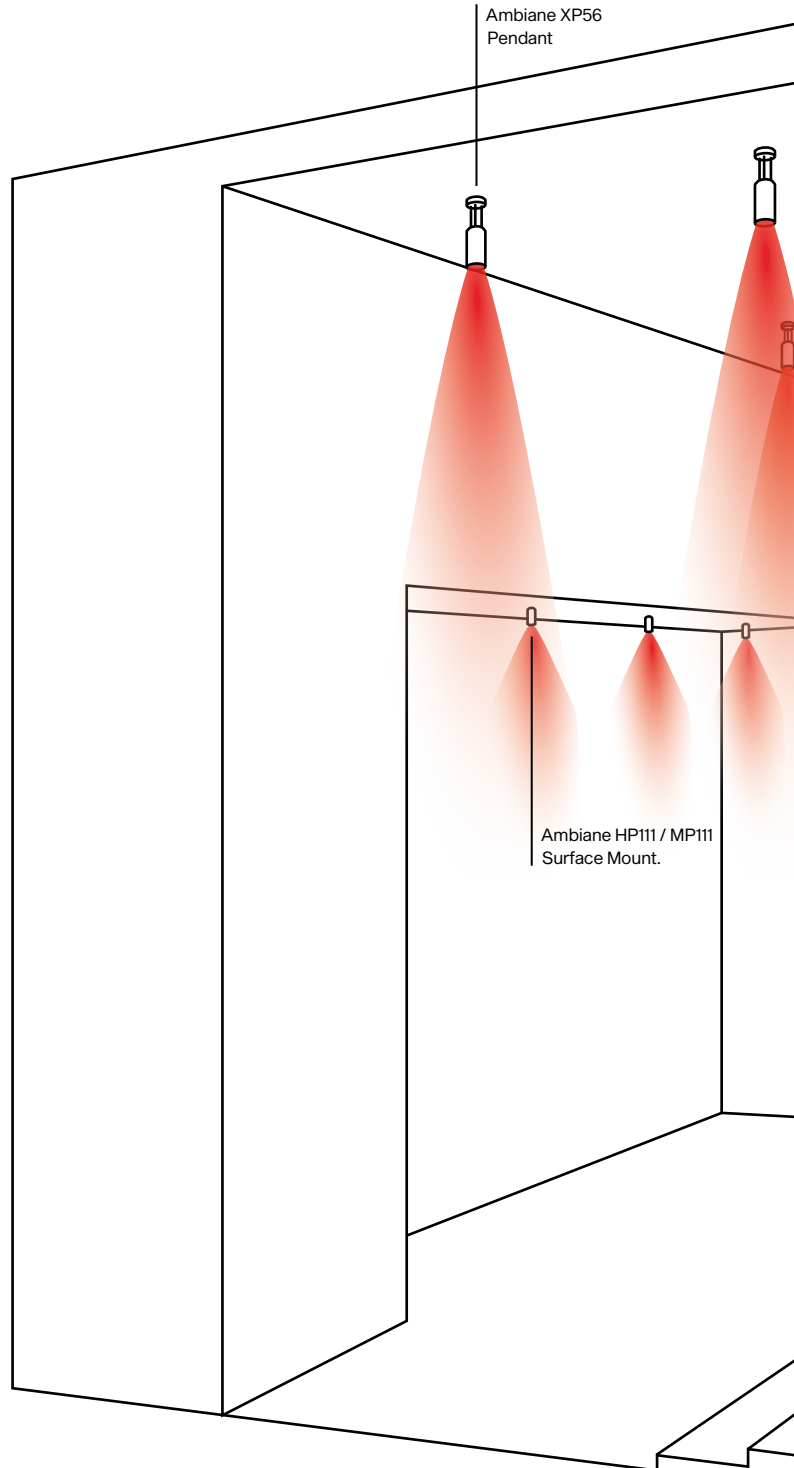

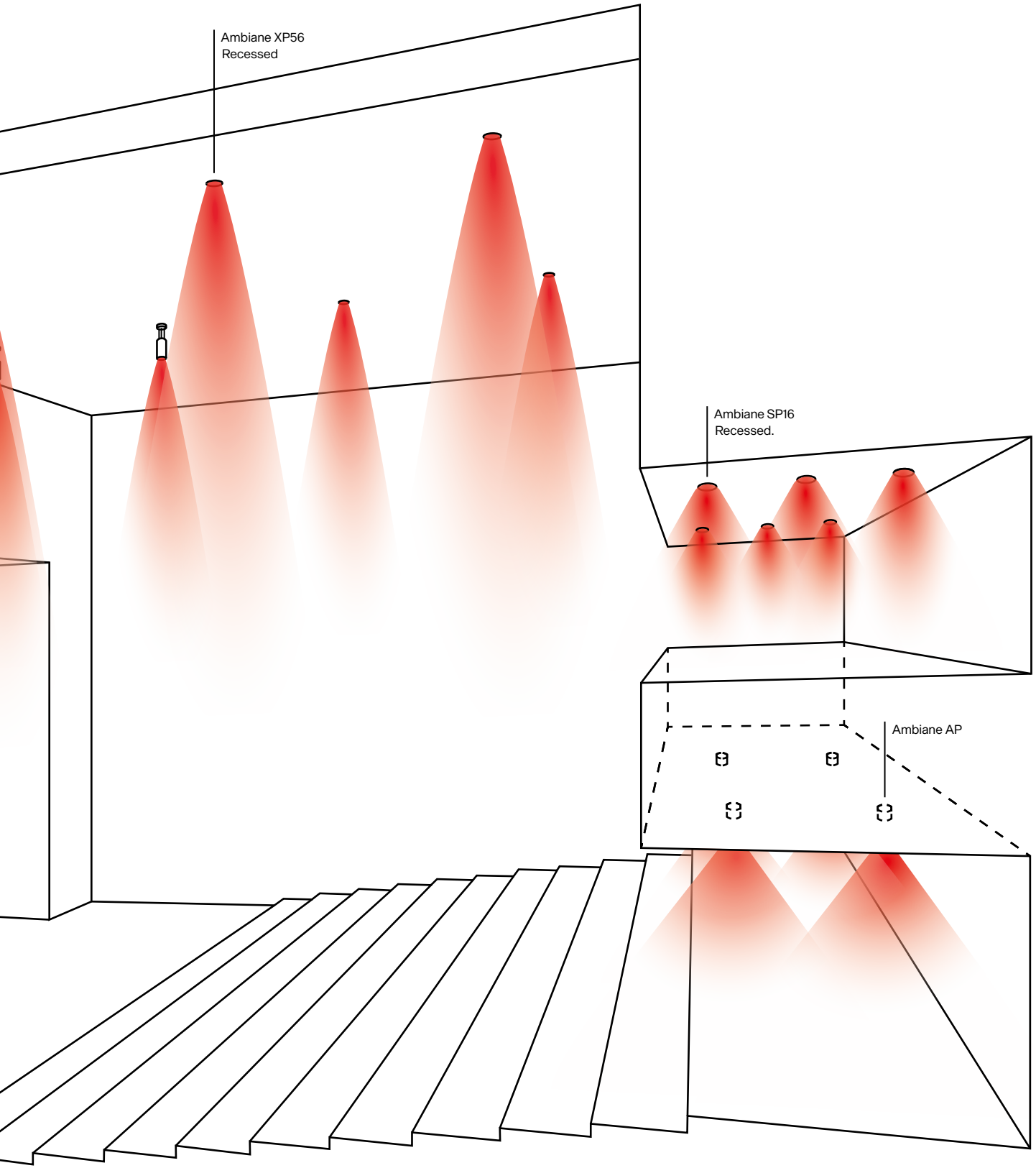

Rakkestad Theatre, Norway

-

Ambiane® HP111

Eminere 4



An Anolis Ambiane auditorium lighting installation is part of a complete revamp at the Rakkestad Theatre, a busy community hub and performance venue. Theatre hosts music events and concerts, theatre, it screens movies as well as being hired out for events, conferences and lectures, so it is truly 'multi-purpose'. Naturally, thinking of sustainability as well as atmosphere, it was a given that previous tungsten lighting should be replaced with LED, and Lighting designer suggested Anolis Ambiane fixtures. The mid-size Ambiane is designed for lower ceiling installations, and they were fitted with 60-degree lenses.





Rakkestad Theatre, Norway  
-  
Ambiane® HP111  
Eminere 4

# Mounting Options

Ambiane luminaires provide mounting options for recessed or pendant luminaires in flat or sloped-ceiling applications. Pendant fixtures are equipped with adjustable hanging wires for the perfect downlight angle and desired length, complemented with pendant remote versions for sloped-ceiling environments. An adapter ring, trim and false ceiling adaptor are available for recessed versions, and the replacement of existing lighting systems is easy thanks to multiple accessories and diameters of fixtures, which are designed to retrofit previous designs.

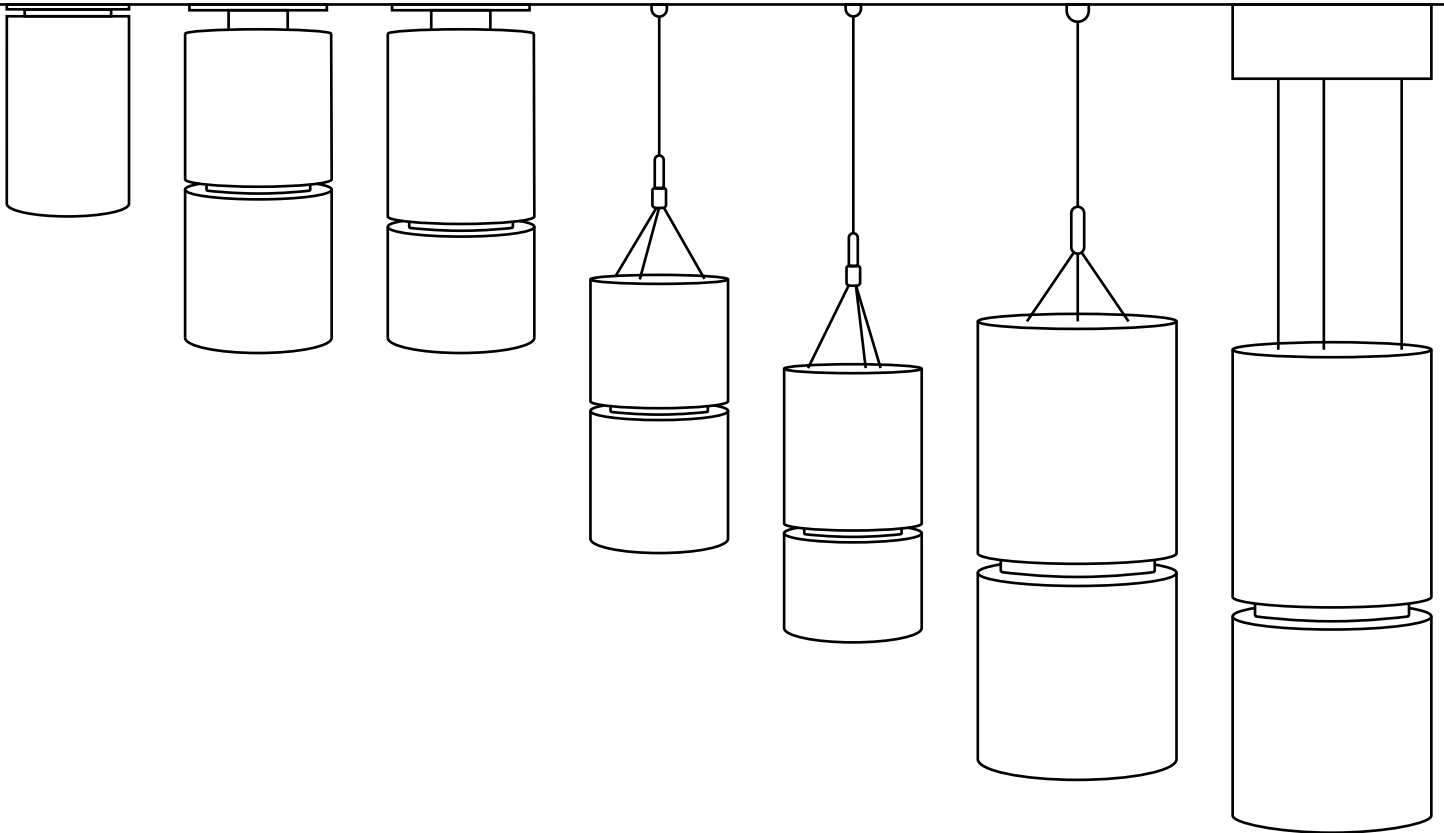

Ambiane SP16  
Surface Mount

Ambiane MP111  
Surface Mount

Ambiane HP111  
Surface Mount

Ambiane MP111  
Pendant Remote

Ambiane HP111  
Pendant Remote

Ambiane XP56  
Pendant Remote

Ambiane XP56  
Pendant

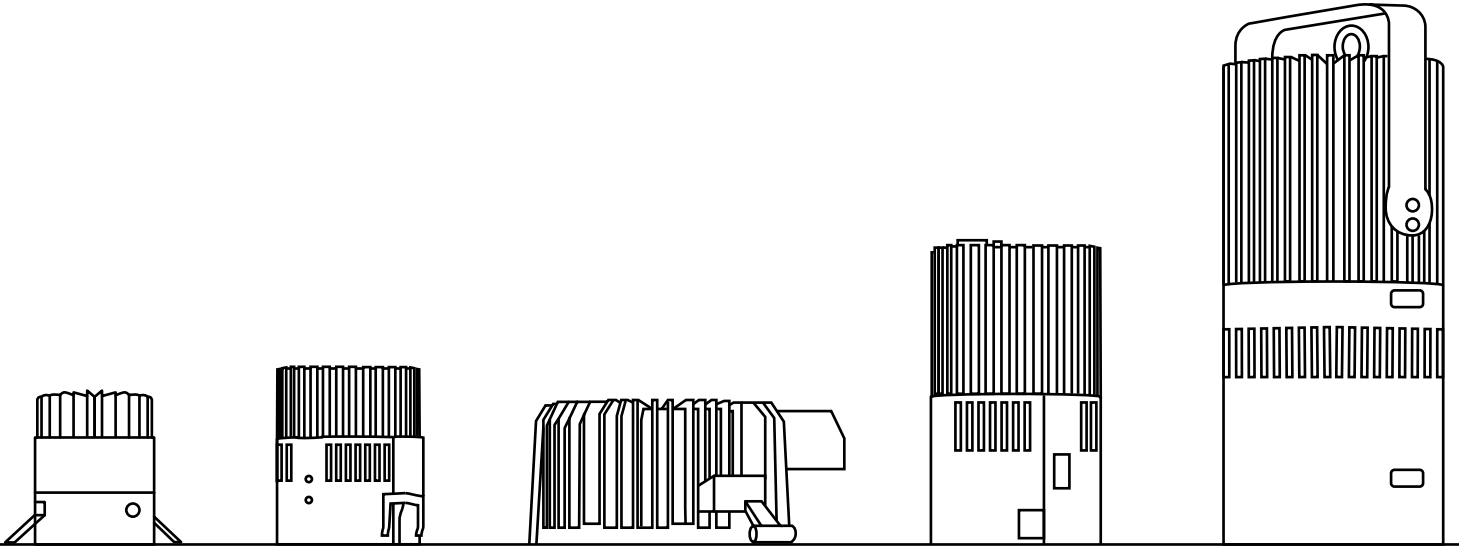

Ambiane SP16  
Recessed

Ambiane MP11  
Recessed

Ambiane AP

Ambiane HP11  
Recessed

Ambiane XP56  
Recessed

# Mounting Options

The Ambiane series of recessed and pendant luminaires has been extended to include tilt versions. Surface mounted tilt luminaires are versatile solutions that offer both functional and aesthetic benefits for different spaces. The ability to tilt or adjust the angle of light allows precise control of the beam direction, making it possible to highlight specific areas, works of art, or architectural features.

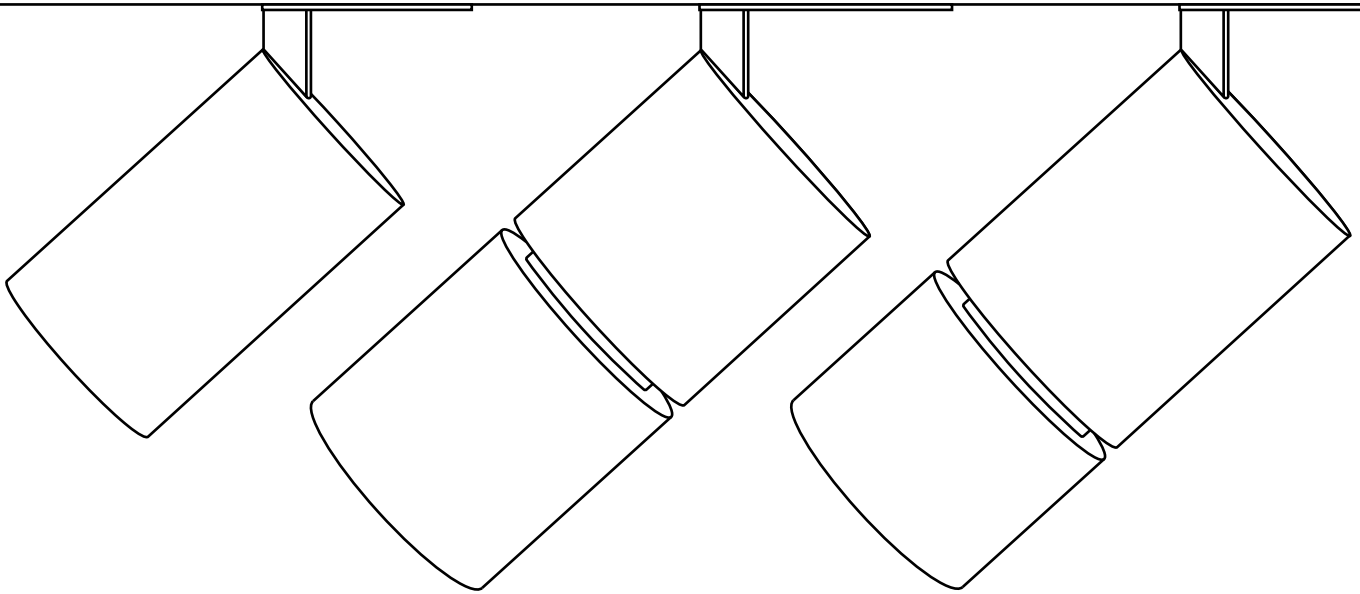

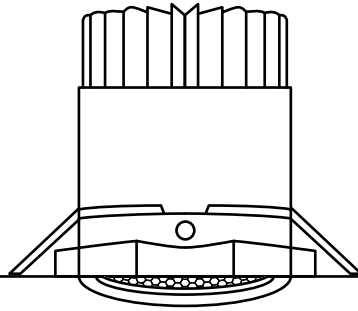

Ambiane SP16  
Recessed Tilt

# Ambiane® Recessed series



Ambiente® SP16 Recessed

30



Ambiente® SP16 Recessed Tilt

32



Ambiente® MP111 Recessed

34



Ambiente® AP

36



Ambiente® HP111 Recessed

38



Ambiente® XP56 Recessed

40

# Ambiane<sup>®</sup> SP16 Recessed



The smallest luminaire of Ambiane range with only 108 mm in diameter offers efficient, powerful and high-quality solution for lower ceiling recessed applications. Highly efficient LED module with CRI 90+, no UV or IR emissions, CCT and green correction settings is perfect for museums, art galleries, theaters, concert halls and other most demanding installations. Sharing the same LED chip-set with other Ambiane fixtures it complements the range and gives lighting designers even more options for various interior lighting installations.





Scale

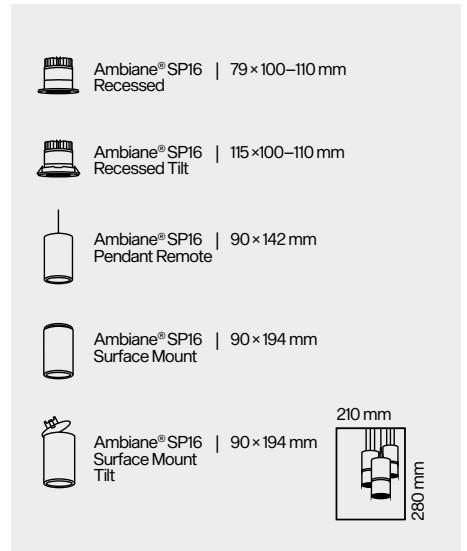

**Lumen output & Light source** Available in wide range of colour configurations (RGBW, PW, TW, TD), the Ambiane SP16 Recessed utilises highly efficient LED modules with CRI 90+. The fixture offers two different beam spreads of 30° and 60°.

**Control** Using DALI or USITT DMX512 control protocols, with RDM support, Ambiane SP16 Recessed can be remotely controlled and managed. Ambiane SP16 Recessed also offers intelligent power balancing.

**Installation** With compact dimensions, Ambiane SP16 Recessed is suitable for lower ceiling applications and to complement our more powerful luminaires of Ambiane range. Ambiane SP16 Recessed is convection cooled for silent operation without fans.

Product Variant



Trim Finish Options

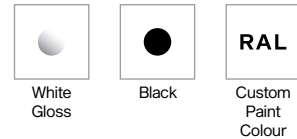

Optic Options

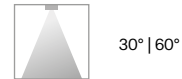

Control & Protocols



Standards and Certifications

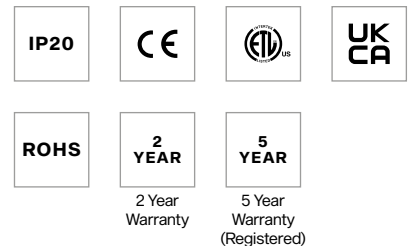

# Ambiane<sup>®</sup> SP16 Recessed Tilt



The smallest luminaire of Ambiane range offers efficient, powerful and high-quality solution for lower ceiling recessed applications. Highly efficient LED module with CRI 90+, no UV or IR emissions, CCT and green correction settings is perfect for museums, art galleries, theaters, concert halls and other most demanding installations. Sharing the same LED chip-set with other Ambiane fixtures it complements the range and gives lighting designers even more options for various interior lighting installations. Tilttable trim 0°–25°.



Scale

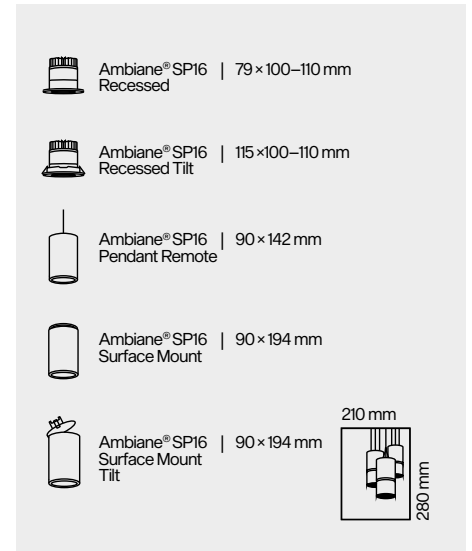

**LED Output** Available in wide range of colour configurations (RGBW, PW, TW, TD), the Ambiane SP16 Recessed utilises highly efficient LED modules with CRI 90+. The fixture offers two different beam spreads of 30° and 60°.

**Control** Using DALI or USITT DMX512 control protocols, with RDM support, Ambiane SP16 Recessed can be remotely controlled and managed. Ambiane SP16 Recessed also offers intelligent power balancing.

**Installation** With compact dimensions and ability to tilt within range of 0°–25°, Ambiane SP16 Recessed is suitable for lower ceiling applications and to complement the standard Ambiane SP16 Recessed as well as our more powerful luminaires of Ambiane range. Ambiane SP16 Recessed Tiltable is convection cooled for silent operation without fans.

Product Variant



Trim Finish Options

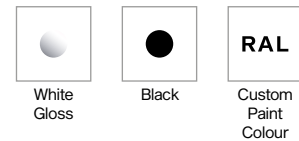

Optic Options

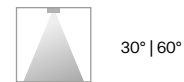

Control & Protocols



Standards and Certifications

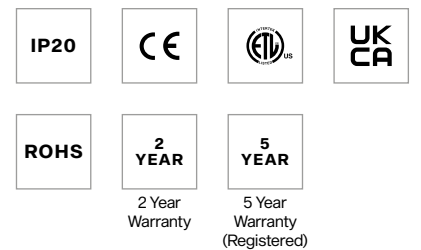

# Ambiane<sup>®</sup> MP111 Recessed



As the mid-size luminaire in the Ambiane series, the new Ambiane MP111 Recessed is designed for lower ceiling installations or to cover areas where the power of the Ambiane HP111 is not necessary. Using the same light source specification as all other Ambiane series members, the fixture is an ideal add-on to lighting designs using a host of Ambiane luminaires. Giving designers and installers a choice of 20, 40, 60 or 80-degree optical beam spreads, the Ambiane MP111 provides an endless array of positioning options across an entire installation. The incorporation of our L3 (Low Light Linearity) dimming system allows seamless fades to black even when mixed with traditional sources. With no UV or IR emissions which make it ideal for museums as well, the fixture is easily controlled via DMX or DALI and is RDM compatible.



Scale

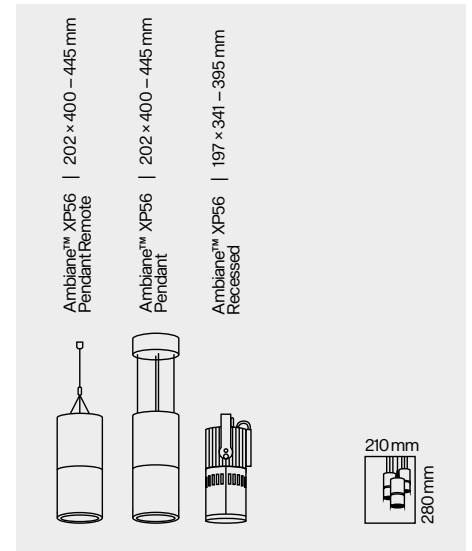

Lumen output & Light source

Available in wide range of colour configurations (RGBW, PW, TW, TD), the Ambiane MP111 Recessed utilises highly efficient LED modules with CRI 90+ ensuring you can always see every colour without colouring distortion. Equally homogenised light output is secured by precisely designed output optics with the highest possible luminous flux 2206 lm and a 90 000 LED lifetime which guarantees low maintenance cost and long-lasting light output. The fixture offers four different beam spreads (20°, 40°, 60° and 80°) for precisely defined light output, required in a lighting installation.

Control

Thanks to our unique L3 (low light linearity) 18-bit dimming system, exceptionally smooth fade to black and colour mixing are now possible. The fixture's remote setting and device management is realised through DALI and DMX512 control protocols with RDM support and intelligent power balancing.

Installation

Mounting via holders into false ceiling as an ideal replacement for an outdated AR111 fixture.

Product Variant



Trim Finish Options

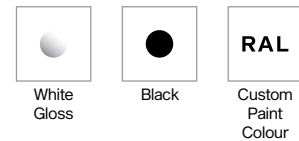

Optic Options



Control & Protocols



Standards and Certifications

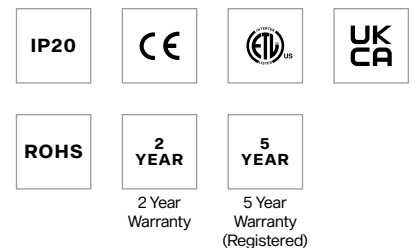

# Ambiane<sup>®</sup> AP



Compact and powerful downlight from Ambiane range is suitable for ambient lighting applications, wall washing and accent lighting where light quality is of the utmost importance. Its high CRI output, simple control mode with CCT, green correction, and perfectly matching dimming curve with tungsten lamps give lighting designers a unique solution without any compromises. Available in RGBW and tunable white CCT versions, along with two beam angles options, the cool-running Ambiane AP is UV or IR radiation free making it ideal for a wide array of applications including theatres, auditoriums, ballrooms, hotels, offices, restaurants, retail environments and more. With both DMX and DALI control options, combined with a highly efficient LED source and high-quality reflectors for optimum light output, the Ambiane AP can produce truly dramatic results.



Scale

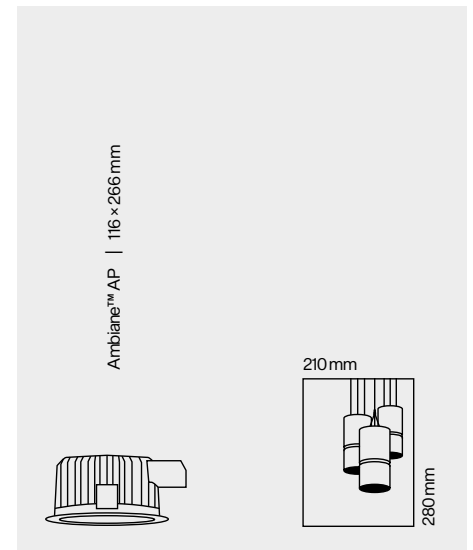

Lumen output & Light source

Available in wide range of colour configurations (RGBW, PW, TW and TD), the high-efficiency LED modules of the Ambiane AP provides the highest possible luminous flux 2713 lm. With two different beam spreads to choose from (67° and 80°), the equally homogenised light output is secured by precisely designed output optics, and the fixture provides a 90 000 hrs LED lifetime guaranteeing a dependable performance.

Control

Thanks to our unique L3 (Low Light Linearity) 18-bit dimming system, exceptionally smooth fade to black and colour mixing are now possible. The fixture's remote setting and device management is realised through DALI and DMX512 control protocols with RDM support and intelligent power balancing (always 50 W output in any mixed colour).

Installation

Fixture is mounted via spring clip holders into false ceiling low 48 V DC input voltage secures a safe light operation with the possibility of backup power connection to protect against any unexpected blackout.

Product Variant



Trim Finish Options

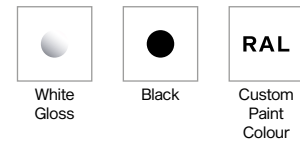

Optic Options



Control & Protocols



Standards and Certifications

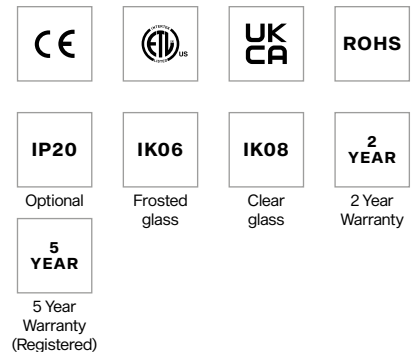

# Ambiane® HP111 Recessed



As the mid-size luminaire in the Ambiane series, the new Ambiane HP111 Recessed is designed for lower ceiling installations or to cover areas where the power of the Ambiane XP56 is not necessary. Using the same light source specification as all other Ambiane series members, the fixture is an ideal add-on to lighting designs using a host of Ambiane luminaires. Giving designers and installers a choice of 20, 40, 60 or 80-degree optical beam spreads, the Ambiane HP111 provides an endless array of positioning options across an entire installation. The incorporation of our L3 (Low Light Linearity) dimming system allows seamless fades to black even when mixed with traditional sources. With no UV or IR emissions which make it ideal for museums as well, the fixture is easily controlled via DMX or DALI and is RDM compatible.





Scale

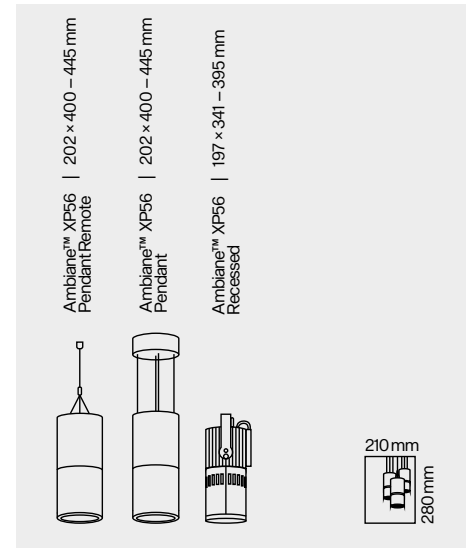

Lumen output & Light source

Available in wide range of colour configurations (RGBW, PW, TW, TD), the Ambiane HP111 Recessed utilises highly efficient LED modules with CRI 90+ ensuring you can always see every colour without colouring distortion. Equally homogenised light output is secured by precisely designed output optics with the highest possible luminous flux 3239 lm and a 90 000 LED lifetime which guarantees low maintenance cost and long-lasting light output. The fixture offers four different beam spreads (20°, 40°, 60° and 80°) for precisely defined light output, required in a lighting installation.

Control

Thanks to our unique L3 (Low Light Linearity) 18-bit dimming system, exceptionally smooth fade to black and colour mixing are now possible. The fixture's remote setting and device management is realised through DALI and DMX512 control protocols with RDM support and intelligent power balancing (always 75 W output in any mixed colour).

Installation

Mounting via holders into false ceiling as an ideal replacement for an outdated AR111 fixture, the Ambiane HP111 offers the possibility of a backup power connection to protect against any unexpected blackout and operate as emergency lighting.

Product Variant



Trim Finish Options

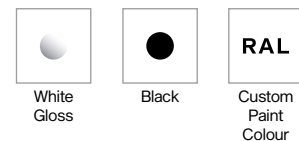

Optic Options

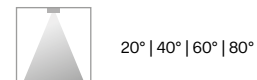

Control & Protocols



Standards and Certifications

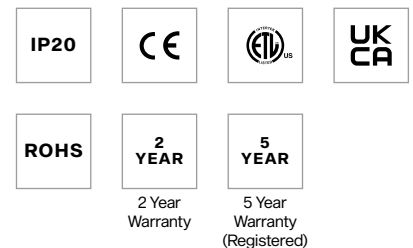

# Ambiane<sup>®</sup> XP56 Recessed



Specifically designed for large theatres, concert halls, auditoriums, houses of worship and hotel foyers that require general ambient light, with the added ability to create mood, the Ambiane XP56 Recessed is the ideal, stylish solution. This high-performance RGBW luminaire delivers in excess of 10 000 lm and is perfect for setting the mood via its super-smooth colour mixing abilities. Available in 20°, 30°, 45° or 60° beam spreads, Ambiane XP56 Recessed provides perfect coverage of any area. The incorporation of our L3 (Low Light Linearity) dimming system allows seamless fades to black even when mixed with traditional sources. With no UV or IR emissions making it ideal for museums as well, the fixture is easily controlled via DMX or DALI and is RDM compatible. Ambiane XP56 Recessed has been designed for easy installation and is perfect to retrofit into existing PAR 56 size cut-outs.



Scale

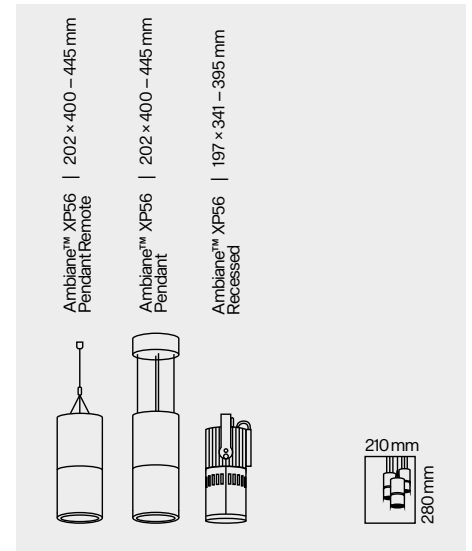

Lumen output & Light source

Available in wide range of colour configurations (RGBW, PW, TW, TD), the Ambiane XP56 Recessed utilises highly-efficient LED modules with CRI 90+ ensuring you can always see every colour as it should be. Through the highest possible luminous flux 10 107 lm, the fixture offers many different beam spreads (20°, 30°, 45° and 60°) for the precise light needed in your lighting installation.

Control

Thanks to our unique L3 (Low Light Linearity) 18-bit dimming system, ultra-smooth fade to black and colour mixing are now possible. The fixture's remote setting and device management is realised through DALI and DMX512 control protocols with RDM support.

Installation

Replacing an old Par 56 has never been easier as Ambiane XP56 Recessed provides an absolutely silent solution thanks to its fanless construction and robust heat sink. Mounted via false ceiling adaptor or standard yoke, it has Trim or Louver as an optional accessory. The low 48 V DC input voltage secure safe light operation and secondary power for back-up lighting.

Product Variant



Trim Finish Options

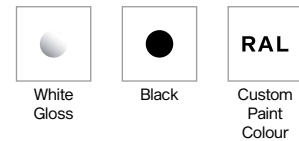

Optic Options



Control & Protocols



Standards and Certifications

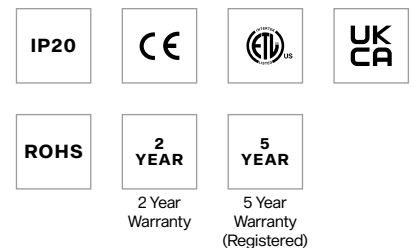



# Ambiane<sup>®</sup> Pendant series



Ambiane® SP16 Pendant Remote

44



Ambiane® MP111 Pendant Remote

46



Ambiane® HP111 Pendant Remote

48



Ambiane® XP56 Pendant Remote

50



Ambiane® XP56 Pendant

52

# Ambiane<sup>®</sup> SP16 Pendant Remote



The smallest luminaire of Ambiane range offers efficient, powerful and high-quality solution for lower ceiling applications. Highly efficient LED module with CRI 90+, no UV or IR emissions, CCT and green correction settings is perfect for museums, art galleries, theaters, concert halls and other most demanding installations. The incorporation of our L3 (Low Light Linearity) dimming system allows seamless fades to black even when mixed with traditional sources. Sharing the same LED chip-set with other Ambiane fixtures it complements the range and gives lighting designers even more options for various interior lighting installations.



Scale

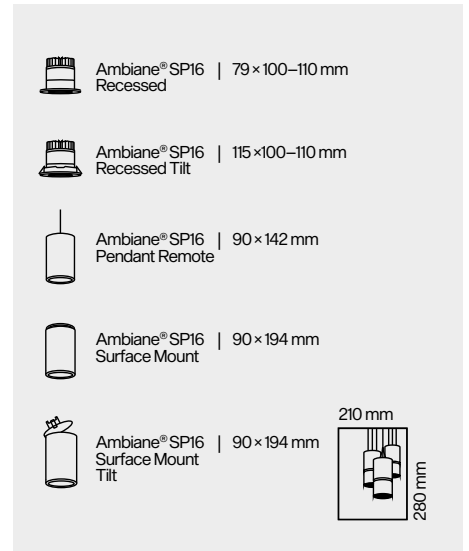

Lumen output & Light source

Available in wide range of colour configurations (RGBW, PW, TW, TD), the Ambiane SP16 Pendant Remote utilises highly efficient LED modules with CRI 90+. The fixture offers two different beam spreads of 30° and 60°.

Control

Using DALI or USITT DMX512 control protocols, with RDM support, Ambiane SP16 Pendant Remote can be remotely controlled and managed. Ambiane SP16 Pendant Remote also offers intelligent power balancing.

Installation

With compact dimensions, Ambiane SP16 Pendant Remote is suitable for lower ceiling applications and to complement our more powerful luminaires of Ambiane range. Ambiane SP16 Pendant Remote is convection cooled for silent operation without fans. Fixture is mounted by one hanging cable for desired position and length.

Product Variant



Trim Finish Options

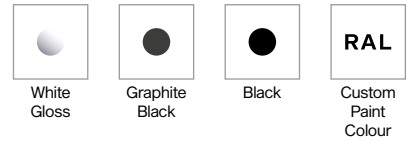

Optic Options

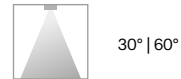

Control & Protocols



Standards and Certifications

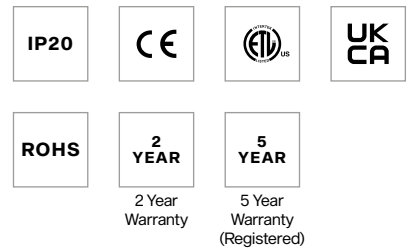

# Ambiane<sup>®</sup> MP111 Pendant Remote



As the mid-size luminaire in the Ambiane series, the new Ambiane MP111 Pendant Remote is designed for lower ceiling installations or to cover areas where the power of the Ambiane HP111 is not necessary. Using the same light source specification as all other Ambiane series members, the fixture is an ideal add-on to lighting designs using a host of Ambiane luminaires. Giving designers and installers a choice of 20, 40, 60 or 80-degree optical beam spreads, the Ambiane MP111 provides an endless array of positioning options across an entire installation. The incorporation of our L3 (Low Light Linearity) dimming system allows seamless fades to black even when mixed with traditional sources. With no UV or IR emissions which make it ideal for museums as well, the fixture is easily controlled via DMX or DALI and is RDM compatible.





Scale

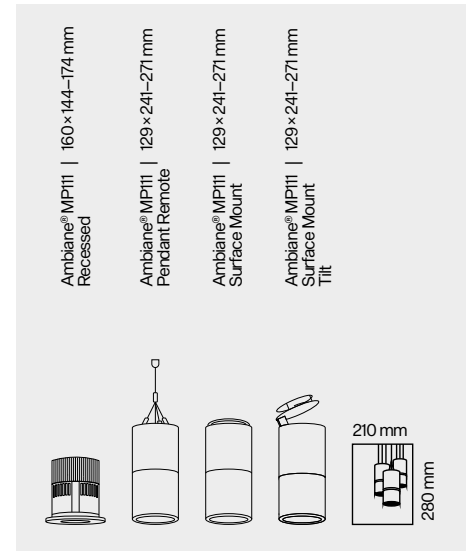

Lumen output & Light source

Available in wide range of colour configurations (RGBW, PW, TW, TD), the Ambiane MP111 Pendant Remote utilises highly efficient LED modules with CRI 90+ ensuring you can always see every colour without colouring distortion. Equally homogenised light output is secured by precisely designed output optics with the highest possible luminous flux 2235 lm and a 90 000 LED lifetime which guarantees low maintenance cost and long-lasting light output. The fixture offers four different beam spreads (20°, 40°, 60° and 80°) for precisely defined light output, required in a lighting installation.

Control

Thanks to our unique L3 (low light linearity) 18-bit dimming system, exceptionally smooth fade to black and colour mixing are now possible. The fixture's remote setting and device management is realised through DALI and DMX512 control protocols with RDM support and intelligent power balancing.

Installation

Mounting via ceiling adaptor and adjustable hanging wires allows installation onto sloped ceilings.

Product Variant



Trim Finish Options

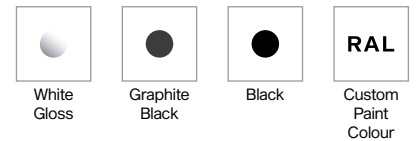

Optic Options

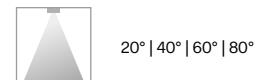

Control & Protocols



Standards and Certifications

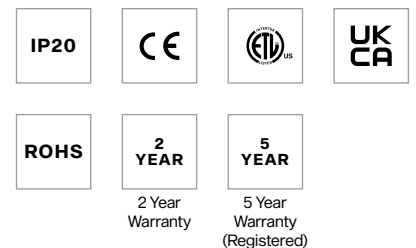

# Ambiane<sup>®</sup> HP111 Pendant Remote



Each Ambiane luminaire is expertly crafted to fit different types of lighting applications. Ambiane HP111 Pendant Remote is meant to fit mid-throw application and able to be mounted onto sloped ceilings. Using the same light source specification as all other Ambiane series members, the fixture is an ideal add-on to lighting designs using a host of Ambiane luminaires. Giving designers and installers a choice of 20, 40, 60 or 80-degree optical beam spreads, the Ambiane HP111 provides an endless array of positioning options across an entire installation. The incorporation of our L3 (Low Light Linearity) dimming system allows seamless fades to black even when mixed with traditional sources. With no UV or IR emissions which make it ideal for museums as well, the fixture is easily controlled via DMX or DALI and is RDM compatible.



Scale

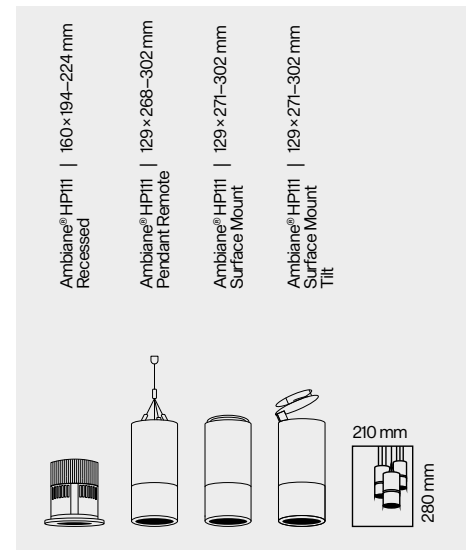

Lumen output & Light source

Available in wide range of colour configurations (RGBW, PW, TW, TD), the Ambiane HP111 Pendant Remote utilises highly efficient LED modules with CRI 90+ ensuring you can always see every colour without colouring distortion. Equally homogenised light output is secured by precisely designed output optics with the highest possible luminous flux 3239 lm and a 90 000 LED lifetime which guarantees low maintenance cost and long-lasting light output. The fixture offers many different beam spreads (20°, 40°, 60° and 80°) for precisely defined light output, required in a lighting installation.

Control

Thanks to our unique L3 (Low Light Linearity) 18-bit dimming system, exceptionally smooth fade to black and colour mixing are now possible. The fixture's remote setting and device management is realised through DALI and DMX512 control protocols with RDM support and intelligent power balancing (always 75 W output in any mixed colour).

Installation

Mounting via ceiling adaptor and adjustable hanging wires allows installation onto sloped ceilings. The Ambiane HP111 Pendant Remote offers the possibility of a backup power connection to protect against any unexpected blackout.

Product Variant



Finish Options

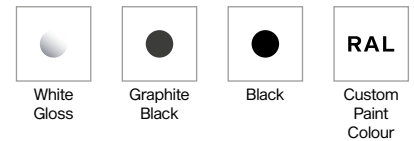

Optic Options



Control & Protocols



Standards and Certifications

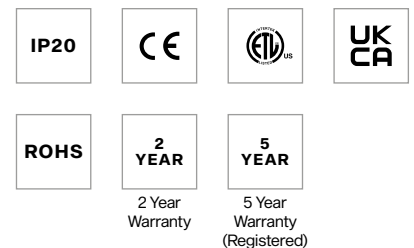

# Ambiane<sup>®</sup> XP56 Pendant Remote



A significant part of architectural lighting, without any doubts, is retrofitting of installations. In reaction to this fact, Anolis has enriched the Ambiane series and offers a new LED pendant version with remote power supply. Using three adjustable wires which allow installers to set an ideal horizontal position of the fixture according to the optical and design requirements, the Ambiane XP56 Pendant Remote power supply uses the existing electrical circuits. Specifically designed for large theatres, concert halls, auditoriums, houses of worship and hotel foyers that require both general ambient light and the ability to control the visual experience, the Ambiane XP56 Pendant is an ideal, stylish solution. Optically, this high-performance RGBW luminaire delivers in excess of 10 000 lm and is perfect for setting the mood via its extremely smooth colour mixing capabilities. Available in 20, 30, 45 or 60-degree beam spreads, Ambiane XP56 Pendant Remote provides perfect coverage of any area. The incorporation of our L3 (Low Light Linearity) dimming system allows seamless fades to black even when mixed with traditional sources. With no UV or IR emissions which make it optimal for museums as well, the fixture is easily controlled via DMX or DALI and is RDM compatible.



Scale

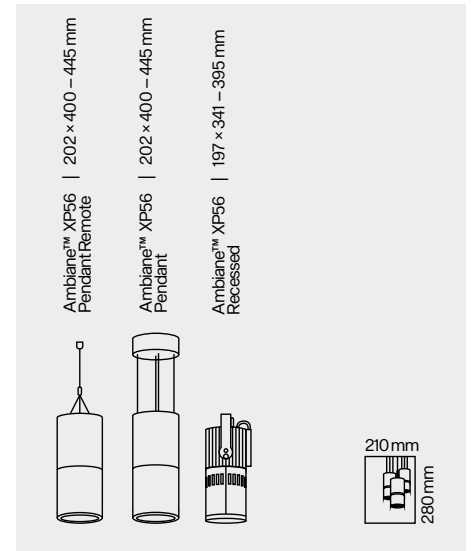

Lumen output & Light source

Available in a wide range of colour configurations (RGBW, PW, TW, TD), the Ambiane XP56 Pendant Remote utilises a high-efficiency LED engine reaching 42 lm/W efficiency. With CRI 90+, you can always see every colour without colouring distortion. The lifetime over 90 000 hrs, provided by its high-quality LED modules, guarantees low maintenance cost and a long-lasting light output. Offering many different beam spreads (20°, 30°, 45° and 60°), you can precisely define light output, required in a lighting installation.

Control

Thanks to our unique L3 (Low Light Linearity) 18-bit dimming system, exceptionally smooth fade to black and colour mixing are now possible. The fixture's remote setting and device management is realised through DALI and DMX512 control protocols with RDM support.

Installation

Fixture is mounted by one hanging wire and three adjustable wires for desired position and length. Power supply is hidden in false ceiling, which allows the fixture to be easily mounted onto slope ceiling. The low 48 V DC input voltage secures a safe light operation with the possibility of a backup power connection to protect against any unexpected blackout.

Product Variant



Finish Options

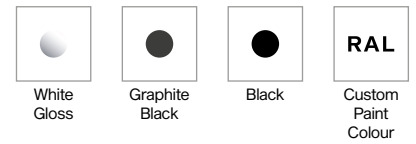

Optic Options



Control & Protocols



Standards and Certifications

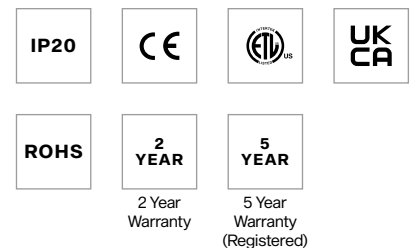

# Ambiane<sup>®</sup> XP56 Pendant



Following the success of our Ambiane XP56 Recessed luminaire for ceiling installations, Anolis introduces our elegant LED pendant for your architectural lighting design. Ambiane XP56 Pendant accommodates three adjustable wires which allow installers to set an ideal horizontal position of the fixture according to the optical and design requirements. Specifically designed for large theatres, concert halls, auditoriums, houses of worship and hotel foyers that require both general ambient light and the ability to control the visual experience, the Ambiane XP56 Pendant is an ideal, stylish solution. Optically, this high-performance RGBW luminaire delivers in excess of 10 000 lm and is perfect for setting the mood via its extremely smooth colour mixing capabilities. Available in 20, 30, 45 or 60-degree beam spreads, Ambiane XP56 provides beautiful illumination in any area. The incorporation of our L3 (Low Light Linearity) dimming system allows seamless fades to black even when mixed with traditional sources. With no UV or IR emissions which make it optimal for museums as well, the fixture is easily controlled via DMX or DALI and is RDM compatible.



Scale

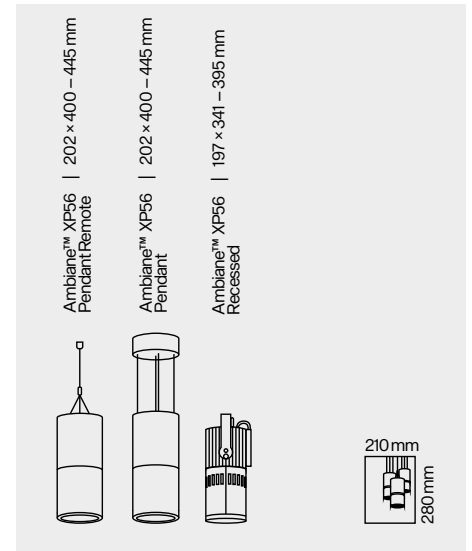

Lumen output & Light source

Available in a wide range of colour configurations (RGBW, PW, TW, TD), the highly efficient LED modules of the Ambiane XP56 Pendant are equally homogenised for a consistent light output. With precision optics and a luminous flux 10 107 lm, the fixture's lifetime 90 000 hrs LED modules guarantee low maintenance cost and long-lasting output. Fixture comes in many different beam spreads (20°, 30°, 45° and 60°), for precisely defined light output, required in a lighting installation.

Control

Thanks to our unique L3 (Low Light Linearity) 18-bit dimming system, exceptionally smooth fade to black and colour mixing are now possible. The fixture's remote setting and device management is realised through DALI and DMX512 control protocols with RDM support.

Installation

Mounted on ceiling and pending on three wires for easy length and position adjustments. Secondary power input for backup lighting option and absolutely silent solution thanks to its fanless construction and robust heat sink.

Product Variant



Finish Options

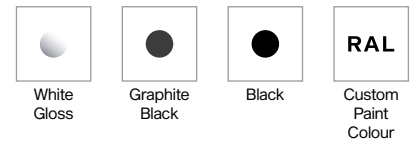

Optic Options



Control & Protocols



Standards and Certifications

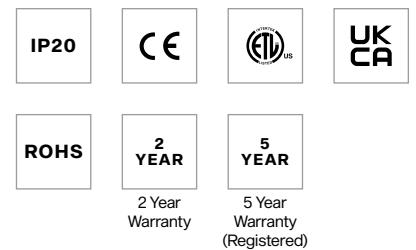



# Ambiane<sup>®</sup> Surface Mount series





Ambiane® SP16 Surface Mount

56



Ambiane® SP16 Surface Mount Tilt

58



Ambiane® MP111 Surface Mount

60



Ambiane® MP111 Surface Mount Tilt

62



Ambiane® HP111 Surface Mount

64



Ambiane® HP111 Surface Mount Tilt

66

# Ambiane<sup>®</sup> SP16 Surface Mount



The smallest luminaire of Ambiane range offers efficient, powerful and high-quality solution for lower ceiling recessed applications. Highly efficient LED module with CRI 90+, no UV or IR emissions, CCT and green correction settings is perfect for museums, art galleries, theaters, concert halls and other most demanding installations. Sharing the same LED chip-set with other Ambiane fixtures it complements the range and gives lighting designers even more options for various interior lighting installations.



Scale

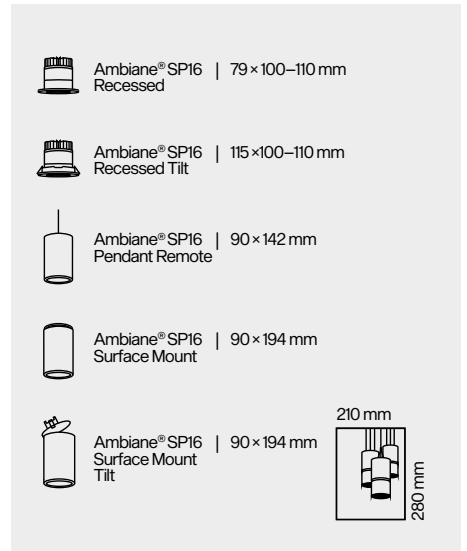

Lumen output & Light source

Available in wide range of colour configurations (RGBW, PW, TW, TD), the Ambiane SP16 Surface Mount utilises highly efficient LED modules with CRI 90+. The fixture offers two different beam spreads of 30° and 60°.

Control

Using DALI or USITT DMX512 control protocols, with RDM support, Ambiane SP16 surface Mount can be remotely controlled and managed. Ambiane SP16 Surface Mount also offers intelligent power balancing.

Installation

With compact dimensions, Ambiane SP16 Surface Mount is suitable for lower ceiling applications and to complement our more powerful luminaires of Ambiane range. Ambiane SP16 Surface Mount is convection cooled for silent operation without fans.

Product Variant



Finish Options

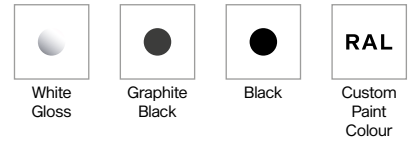

Optic Options

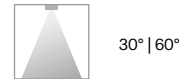

Control & Protocols



Standards and Certifications

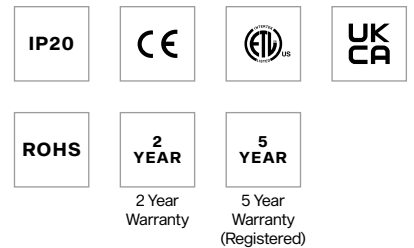

# Ambiane<sup>®</sup> SP16 Surface Mount Tilt



The smallest luminaire of Ambiane range offers efficient, powerful and high-quality solution for lower ceiling recessed applications. Highly efficient LED module with CRI 90+, no UV or IR emissions, CCT and green correction settings is perfect for museums, art galleries, theaters, concert halls and other most demanding installations. Sharing the same LED chip-set with other Ambiane fixtures it complements the range and gives lighting designers even more options for various interior lighting installations. Tiltable 0°–90°.

The photo showcases an Ceiling Mount Version



Scale

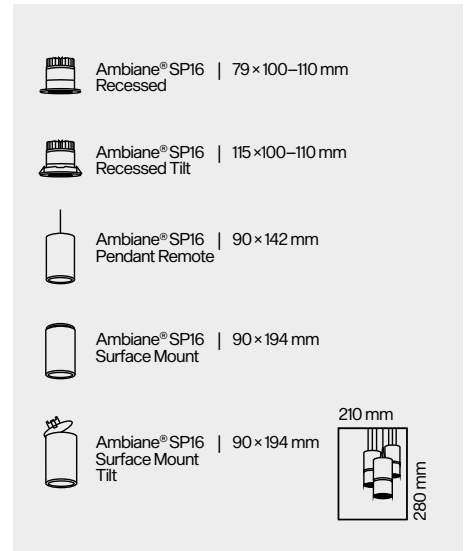

Lumen output & Light source

Available in wide range of colour configurations (RGBW, PW, TW, TD), the Ambiane SP16 Surface Mount utilises highly efficient LED modules with CRI 90+. The fixture offers two different beam spreads of 30° and 60°.

Control

Using DALI or USITT DMX512 control protocols, with RDM support, Ambiane SP16 Surface Mount can be remotely controlled and managed. Ambiane SP16 Surface Mount also offers intelligent power balancing.

Installation

With compact dimensions, Ambiane SP16 Surface Mount is suitable for lower ceiling applications and to complement our more powerful luminaires of Ambiane range. Ambiane SP16 Surface Mount is convection cooled for silent operation without fans.

Product Variant



Finish Options

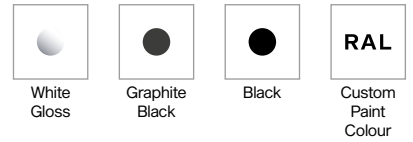

Optic Options



Control & Protocols



Standards and Certifications

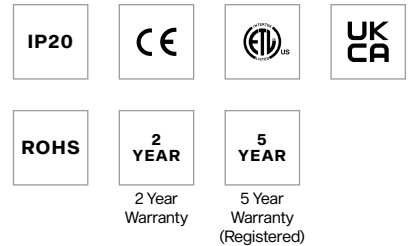

# Ambiane<sup>®</sup> MP111 Surface Mount



As the mid-size luminaire in the Ambiane series, the new Ambiane MP111 Surface Mount is designed for lower ceiling installations or to cover areas where the power of the Ambiane HP111 is not necessary. Using the same light source specification as all other Ambiane series members, the fixture is an ideal add-on to lighting designs using a host of Ambiane luminaires. Giving designers and installers a choice of 20, 40, 60 or 80-degree optical beam spreads, the Ambiane MP111 provides an endless array of positioning options across an entire installation. The incorporation of our L3 (Low Light Linearity) dimming system allows seamless fades to black even when mixed with traditional sources. With no UV or IR emissions which make it ideal for museums as well, the fixture is easily controlled via DMX or DALI and is RDM compatible.



Lumen output & Light source

Available in wide range of colour configurations (RGBW, PW, TW, TD), the Ambiane MP111 Surface Mount utilises highly efficient LED modules with CRI 90+ ensuring you can always see every colour without colouring distortion. Equally homogenised light output is secured by precisely designed output optics with the highest possible luminous flux 2235 lm and a 90 000 LED lifetime which guarantees low maintenance cost and long-lasting light output. The fixture offers four different beam spreads (20°, 40°, 60° and 80°) for precisely defined light output, required in a lighting installation.

Control

Thanks to our unique L3 (low light linearity) 18-bit dimming system, exceptionally smooth fade to black and colour mixing are now possible. The fixture's remote setting and device management is realised through DALI and DMX512 control protocols with RDM support and intelligent power balancing.

Scale

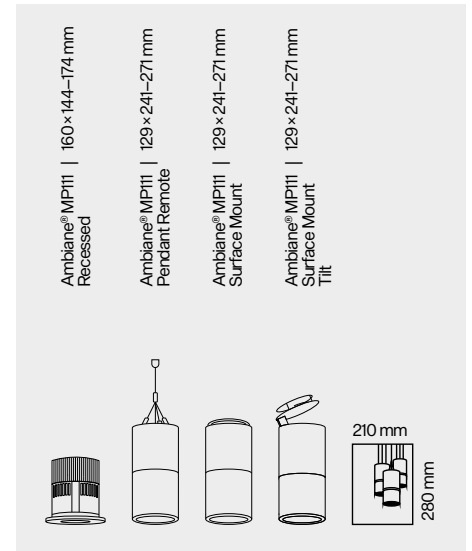

Product Variant



Finish Options

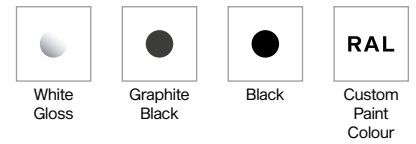

Optic Options



Control & Protocols



Standards and Certifications

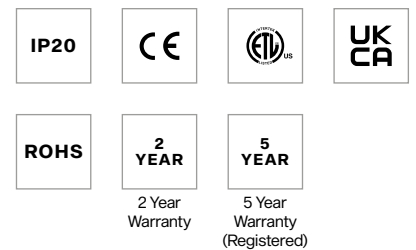

# Ambiane<sup>®</sup> MP111 Surface Mount Tilt



As the mid-size luminaire in the Ambiane series, the new Ambiane MP111 Surface Mount is designed for lower ceiling installations or to cover areas where the power of the Ambiane HP111 is not necessary. Using the same light source specification as all other Ambiane series members, the fixture is an ideal add-on to lighting designs using a host of Ambiane luminaires. Giving designers and installers a choice of 20, 40, 60 or 80-degree optical beam spreads, the Ambiane MP111 provides an endless array of positioning options across an entire installation. The incorporation of our L3 (Low Light Linearity) dimming system allows seamless fades to black even when mixed with traditional sources. With no UV or IR emissions which make it ideal for museums as well, the fixture is easily controlled via DMX or DALI and is RDM compatible. Tilt 0°–80°.





Lumen output & Light source

Available in wide range of colour configurations (RGBW, PW, TW, TD), the Ambiane MP111 surface Mount utilises highly efficient LED modules with CRI 90+ ensuring you can always see every colour without colouring distortion. Equally homogenised light output is secured by precisely designed output optics with the highest possible luminous flux 2235 lm and a 90 000 LED lifetime which guarantees low maintenance cost and long-lasting light output. The fixture offers four different beam spreads (20°, 40°, 60° and 80°) for precisely defined light output, required in a lighting installation.

Control

Thanks to our unique L3 (low light linearity) 18-bit dimming system, exceptionally smooth fade to black and colour mixing are now possible. The fixture's remote setting and device management is realised through DALI and DMX512 control protocols with RDM support and intelligent power balancing.

Scale

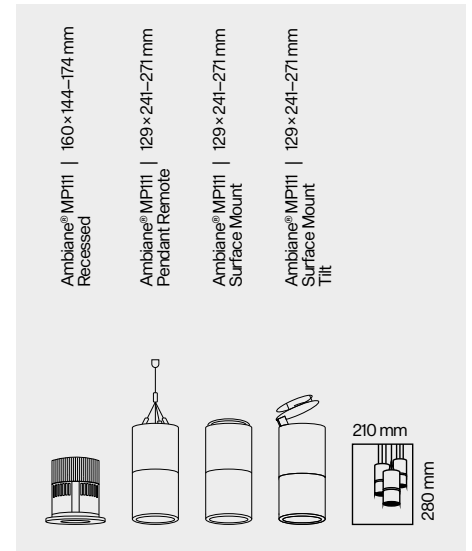

Product Variant



Finish Options

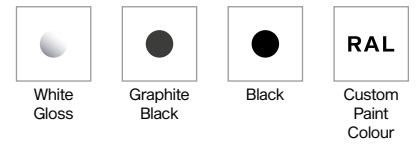

Optic Options



Control & Protocols



Standards and Certifications

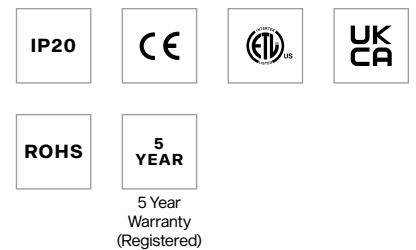

# Ambiane<sup>®</sup> HP111 Surface Mount



Surface mount version of Ambiane is ideal for mid-throw application onto a levelled ceiling. Same light source specification hidden inside of the beautiful design makes this fixture an ideal add-on to lighting design of Ambiane series. Giving designers and installers a choice of 20, 40, 60 or 80-degree optical beam spreads, the Ambiane HP111 provides an endless array of positioning options across an entire installation. The incorporation of our L3 (Low Light Linearity) dimming system allows seamless fades to black even when mixed with traditional sources. With no UV or IR emissions which make it ideal for museums as well, the fixture is easily controlled via DMX or DALI and is RDM compatible.



Lumen output & Light source

Available in wide range of colour configurations (RGBW, PW, TW, TD), the Ambiane HP111 Surface Mount utilises highly efficient LED modules with CRI 90+ ensuring you can always see every colour as it should be. Equally homogenised light output is secured by precisely designed output optics with the highest possible luminous flux 3239 lm and a 90 000 LED lifetime which guarantees low maintenance cost and long light output. The fixture offers many different beam spreads (20°, 40°, 60° and 80°) for the precise light needed in your lighting installation.

Control

Thanks to our unique L3 (Low Light Linearity) 18-bit dimming system, exceptionally smooth fade to black and colour mixing are now possible. The fixture's remote setting and device management is realised through DALI and DMX512 control protocols with RDM support and intelligent power balancing (always 75 W output in any mixed colour).

Installation

An ideal replacement for an outdated AR111 fixture, the Ambiane HP111 Surface Mount offers the possibility of a backup power connection to protect against any unexpected blackout.

Scale

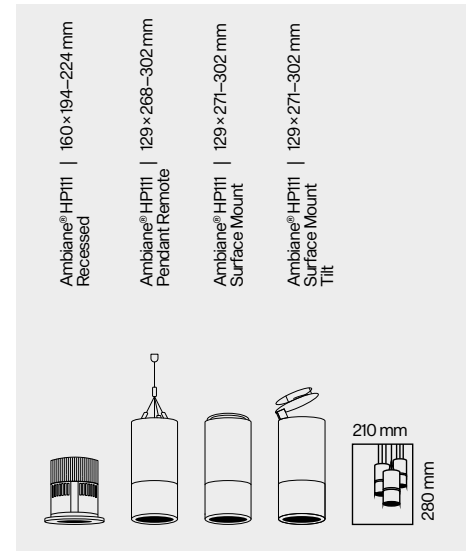

Product Variant



Finish Options

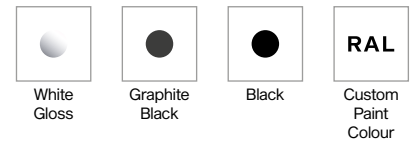

Optic Options



Control & Protocols



Standards and Certifications

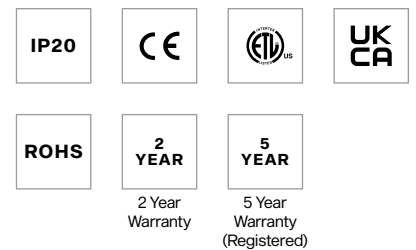

# Ambiane<sup>®</sup> HP111 Surface Mount Tilt



Surface mount version of Ambiane is ideal for mid-throw application onto a levelled ceiling. Same light source specification hidden inside of the beautiful design makes this fixture an ideal add-on to lighting design of Ambiane series. Giving designers and installers a choice of 20, 40, 60 or 80-degree optical beam spreads, the Ambiane HP111 provides an endless array of positioning options across an entire installation. The incorporation of our L3 (Low Light Linearity) dimming system allows seamless fades to black even when mixed with traditional sources. With no UV or IR emissions which make it ideal for museums as well, the fixture is easily controlled via DMX or DALI and is RDM compatible. Tilt 0°–80°.



Lumen output & Light source

Available in wide range of colour configurations (RGBW, PW, TW, TD), the Ambiane HP111 Surface Mount utilises highly efficient LED modules with CRI 90+ ensuring you can always see every colour as it should be. Equally homogenised light output is secured by precisely designed output optics with the highest possible luminous flux 3239 lm and a 90 000 LED lifetime which guarantees low maintenance cost and long light output. The fixture offers many different beam spreads (20°, 40°, 60° and 80°) for the precise light needed in your lighting installation.

Control

Thanks to our unique L3 (low light linearity) 18-bit dimming system, exceptionally smooth fade to black and colour mixing are now possible. The fixture's remote setting and device management is realised through DALI and DMX512 control protocols with RDM support and intelligent power balancing (always 75 W output in any mixed colour).

Installation

An ideal replacement for an outdated AR111 fixture, the Ambiane HP111 Surface Mount offers the possibility of a backup power connection to protect against any unexpected blackout and operate as emergency lighting.

Scale

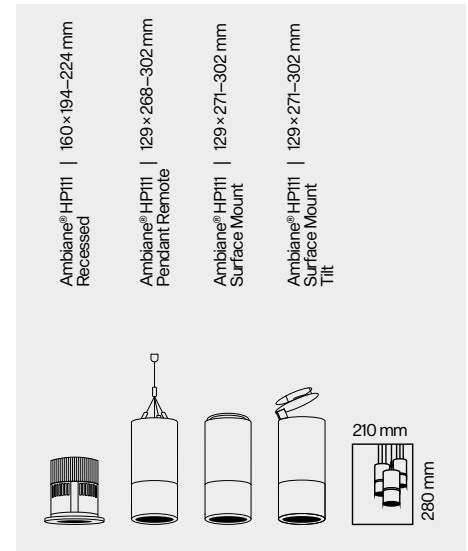

Product Variant



Finish Options

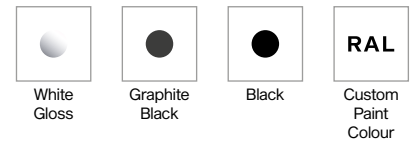

Optic Options



Control & Protocols



Standards and Certifications

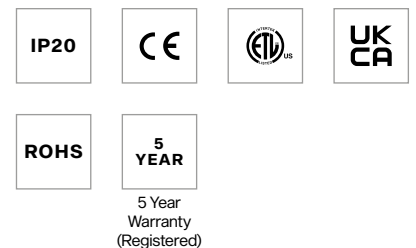

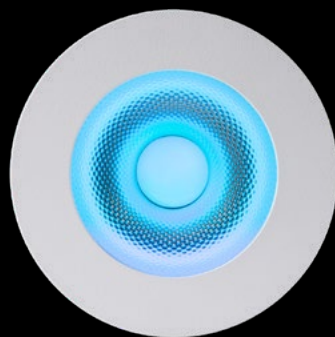

Ambiane<sup>®</sup> series

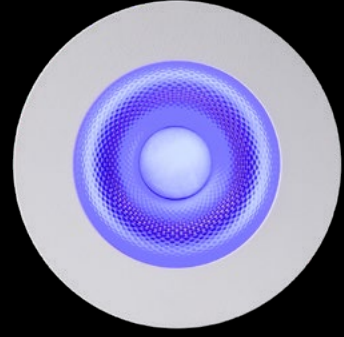
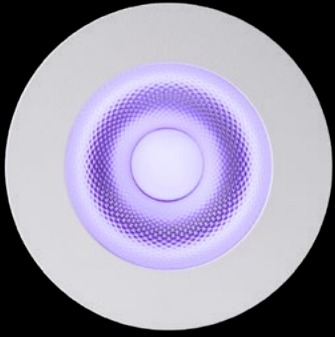

www.anolislighting.com

info@anolis.eu  
+420 571 751 500

**Head Office**

Anolis  
Házovice 2090  
756 61 Rožnov pod Radhoštěm  
Czech Republic

**Factory**

Anolis  
Palackého 416  
757 01 Valašské Meziříčí  
Czech Republic

Graphics, composition  
KNOW HOW solutions s.r.o.

Issue  
EN 08/2024

© 2024 Anolis  
All specifications subject to change without notice.





