

Calumma S MC Calumma S SC

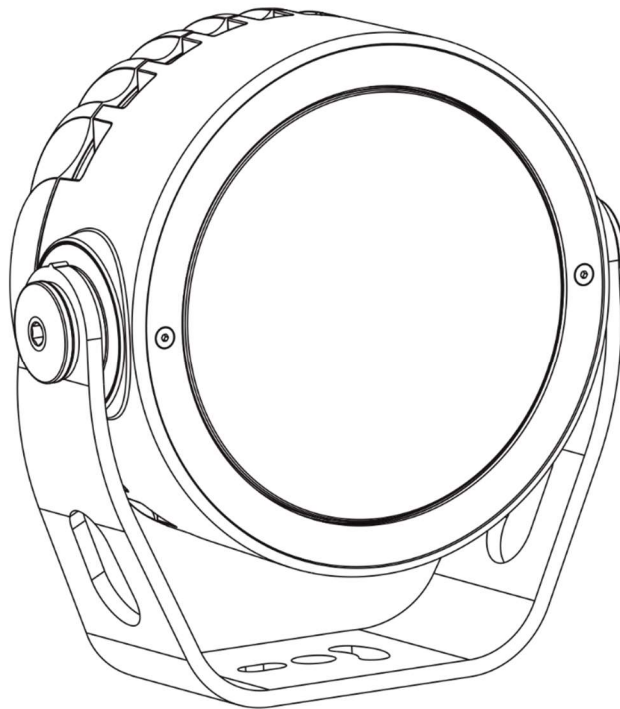

QR code for user manual



Table of contents

1. Safety instructions	3
2. Fixture exterior view	5
3. Installation	5
3.1 Mounting the fixture	5
3.2 Connection to mains	8
4. Control and connection options	10
4.1 DMX or DALI	10
4.2 Power On/Off	11
4.3 DMX or Ethernet via E-box	12
4.4 Example of Control panel in RDM manager	15
5. Software update	17
6. Technical specifications	19
7. Cleaning and maintenance	26
7.1 Disposing of the product	26
8. ChangeLog	27

**FOR YOUR OWN SAFETY, PLEASE READ THIS USER MANUAL CAREFULLY
BEFORE POWERING OR INSTALLING YOUR Calumma !
Save it for future reference.**

This device has left our premises in absolutely perfect condition. In order to maintain this condition and to ensure safe operation, it is absolutely necessary for the user to follow the safety instructions and warnings written in this manual.

The manufacturer will not accept liability for any resulting damages caused by the non-observance of this manual or any unauthorized modification to the device.

Unauthorized modification will void warranty.

1. Safety instructions

DANGEROUS VOLTAGE CONSTITUTING A RISK OF ELECTRIC SHOCK IS PRESENT WITHIN THIS UNIT!

This fixture should be operated only from the type of power source indicated on the marking label. If you are not sure of the type of power supplied, consult your authorized distributor or local power company.

Always disconnect the fixture from AC power before servicing or cleaning.

Make sure the power/data cable is not damaged by sharp edges.

Do not install the unit near an open flame.

Refer servicing to qualified service personnel.

This fixture falls under protection class I. Therefore this fixture has to be connected to a mains socket outlet with a protective earthing connection.

Do not connect this fixture to a dimmer pack.

LED light emission. Risk of eye injury. Do not look into the beam from a short distance without suitable protective eyewear. Do not look at LEDs with magnifiers or similar optical instruments that may concentrate the light output.

The fixture was designed for outdoor use. This fixture must not be used for underwater installation.

When choosing the installation spot, please make sure that the fixture is not exposed to extreme heat or dust.

Avoid using the unit in locations subject to possible impacts.

The fixture body never must be covered with cloth or other materials when the fixture is under operation.

Only operate the fixture after having checked that the housing is firmly closed and all screws are tightly fastened.

The fixture becomes hot during operation. Allow the fixture to cool approximately 30 minutes prior to servicing or maintenance.

Please consider that unauthorized modifications on the fixture are forbidden due to safety reasons!

Calumma S

Please use the original packaging if the fixture is to be transported.

If this device will be operated in any way different to the one described in this manual, the product may suffer damages and the warranty becomes void. Furthermore, any other operation may lead to dangers like short-circuit, burns, electric shock etc.

The product (covers and cables) must not be exposed to a high frequency electromagnetic field higher than 3V/m.

Immunity of the equipment is designed according to the standard EN 55035 Electromagnetic compatibility of multimedia equipment - Immunity requirements

Emission of the equipment complies with the standard EN55032 Electromagnetic compatibility of multimedia equipment – Emission Requirements according to class B.

Contains FCC ID: 2A6PL-DMXRDMRW001

Contains IC: 29573-DMXRDMRW001

This device complies with part 15 of the FCC Rules. Operation is subject to the following two conditions: (1) This device may not cause harmful interference, and (2) this device must accept any interference received, including interference that may cause undesired operation.

Changes or modifications not expressly approved by the party responsible for compliance could void the user's authority to operate the equipment.

The [Device] wireless operation is safe and complies to RF Exposure requirements.

This equipment has been tested and found to comply with the limits for a Class B digital device, pursuant to part 15 of the FCC Rules. These limits are designed to provide reasonable protection against harmful interference in a residential installation. This equipment generates, uses and can radiate radio frequency energy and, if not installed and used in accordance with the instructions, may cause harmful interference to radio communications. However, there is no guarantee that interference will not occur in a particular installation. If this equipment does cause harmful interference to radio or television reception, which can be determined by turning the equipment off and on, the user is encouraged to try to correct the interference by one or more of the following measures:

- Reorient or relocate the receiving antenna.
- Increase the separation between the equipment and receiver.
- Connect the equipment into an outlet on a circuit different from that to which the receiver is connected.
- Consult the dealer or an experienced radio/TV technician for help.

Warning for fixtures with Harsh Environment Finish (HEF):

Handle with care!

Avoid any damage to the painted surface.

Damaging the paint may result in corrosion and loss of warranty.

2. Fixture exterior view

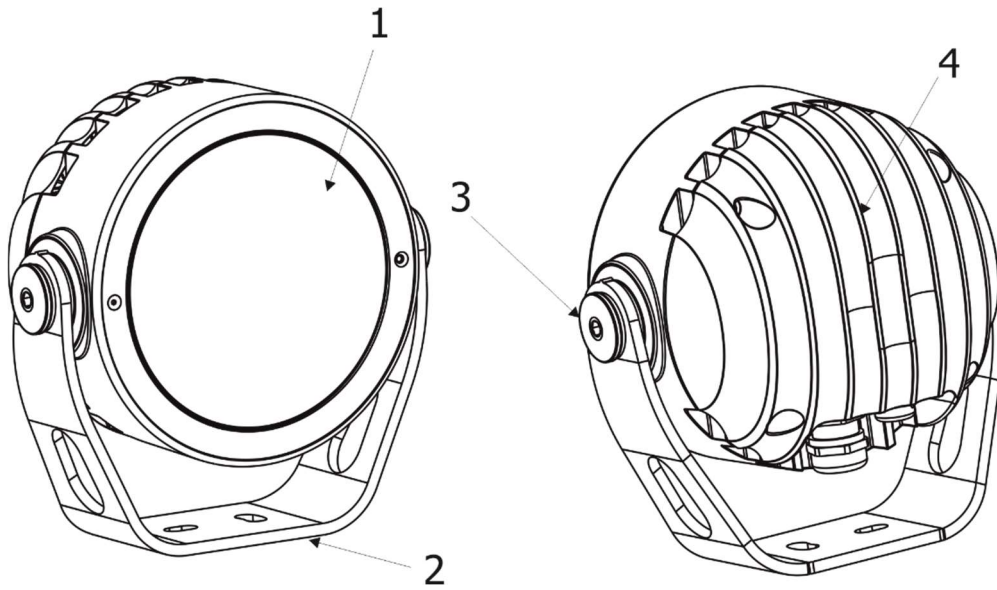

1. Transparent glass cover
2. Mounting yoke
3. Tilt adjusting lock
4. LED module with heat sink

3. Installation

3.1 Mounting the fixture

The Calumma S can be fastened in any orientation on a flat, non-flammable surface by means of mounting yoke (2).

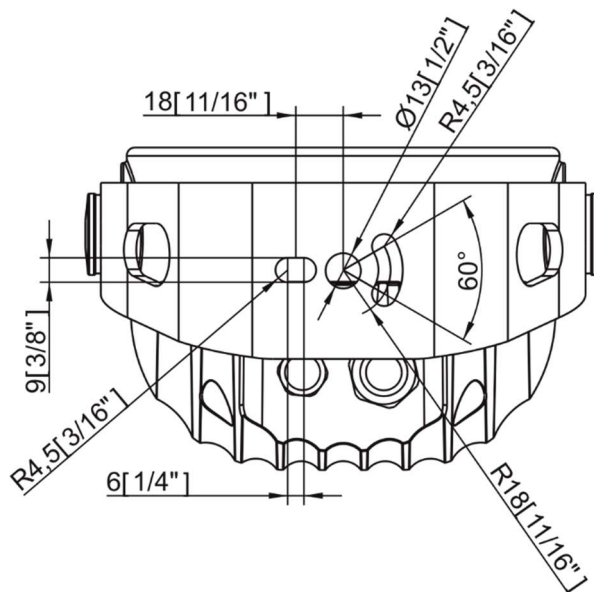

The LED module (4) can be tilted $+180^{\circ}/-180^{\circ}$. Use an Allen key 2.5 for adjusting a LED module position.

Ensure that the structure to which you are attaching the fixture is secure.

Calumma S

Mounting the fixture via the pole clamp adaptor

The pole clamp adaptor serves as a fastening element for Calumma S on a pole of diameter of 76-116mm or on the flat pole. The Calumma S has to be equipped with a modified mounting yoke (P/N 11418772) intended for this way of installation.

The pole clamp adaptor set includes: 1x pole clamp adaptor, 1x rubber cable gland, 3x Allen screw M8x20, 3x flat washer, 3x spring washer, 2x tube spacer.

1. The pole clamp adaptor can be screwed on the pole by means of two screws or fixed by means of a steel clamping tape (max. width of tape=20mm).

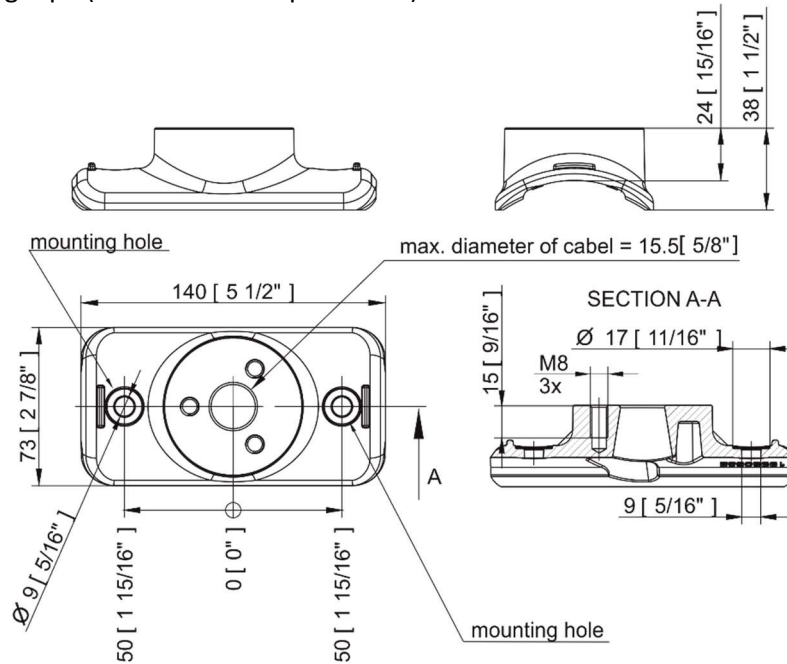

If you use two screws for fastening the pole clamp adaptor on the pole, drill two holes (1) for fastening the pole clamp adaptor on the pole. Diameter of holes depends on material of pole and used screws. Be sure that fastening of the pole clamp adaptor is secure to keep weight of Calumma.

2. Drill the hole (2) for rubber cable gland (diameter of hole=20mm, max. thickness of pole wall= 3.2mm), make drilled hole edges clean (without burrs) and insert the rubber gland into the hole.

Calumma S

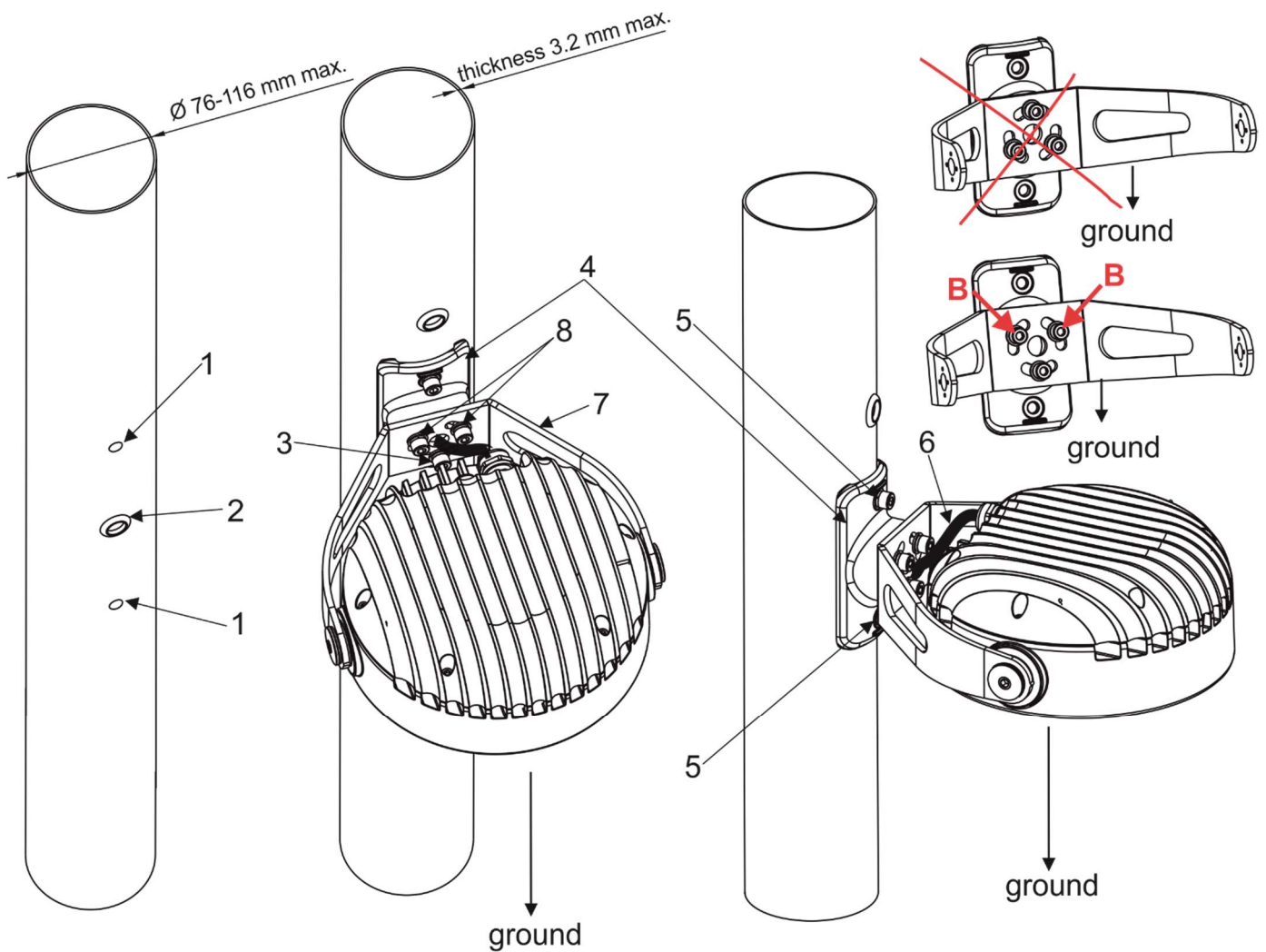

3. Screw the pole clamp adaptor (4) on the pole by means of two screws (5) with spring washers or use a steel clamping tape for fastening the pole clamp adaptor on the pole.
In case of screwing the pole clamp adaptor (7) on a flat surface (pole), two pole spacers have to be inserted under two mounting holes of the pole clamp adaptor (on fastening screws (5)) to fill up space between the pole and the pole clamp adaptor
4. Pass the Calumma cable (6) through mounting yoke (7), pole clamp adaptor (4) and through cable gland (2) into the pole.
5. Screw the Calumma mounting yoke (7) on the pole clamp adaptor (4) by means of three Allen screws M8x20 (3) with washers (Allen screw + spring washer+ flat washer). Keep correct orientation of the fastening screws (3) as drawn on the picture – two screws (B) have to aim upwards, one screw has to be orientated towards ground.
NOTE. Three mounting openings in the mounting yoke allow positioning of the mounting yoke in range of 0°- 360°.

3.2 Connection to mains

***The unit must be installed by a qualified electrician in accordance with all national and local electrical and construction codes and regulations.
This device falls under class one and must be grounded!***

The Calumma is equipped with auto-switching power supply that automatically adjusts to any 50/60Hz AC power source from 120-277 Volts.

3.2.1 Junction box installation

The junction box falls under protection class I . Therefore, every junction box has to be connected to a mains socket outlet with a protective earthing connection.

1. Unscrew the four screws (1) from the cover (2) on the junction box to get access to the terminal block (3) and two mounting holes of diameter of 4.6 mm (4).
2. Screw the junction box on a non-flammable flat surface.

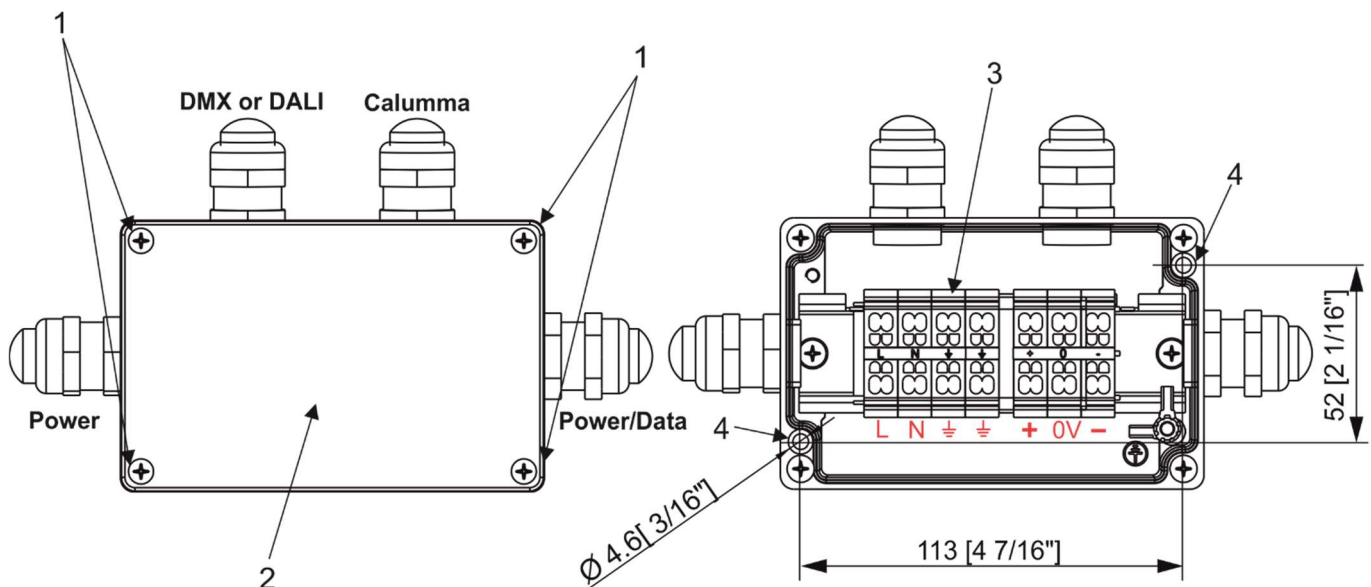

3. Connect cables.

The cable gland M20 x 1.5 with a standard seal serves for a cable of diameter of 7-13mm, for smaller diameter of cable (4-8mm) you have to remove the original seal from the cable gland M20x1.5 and use the enclosed reducing seal instead of it. The reducing seal for diameter of cable 4-8mm (P/N 13051388) is enclosed in the Junction box. Remove the end cap from the cable gland before passing the cable.

We recommend to apply an adequate layer of the paste LOCTITE 5331 on the plastic holder of the cable gland before inserting it into the body of the gland.

Cable gland M20x1.5:

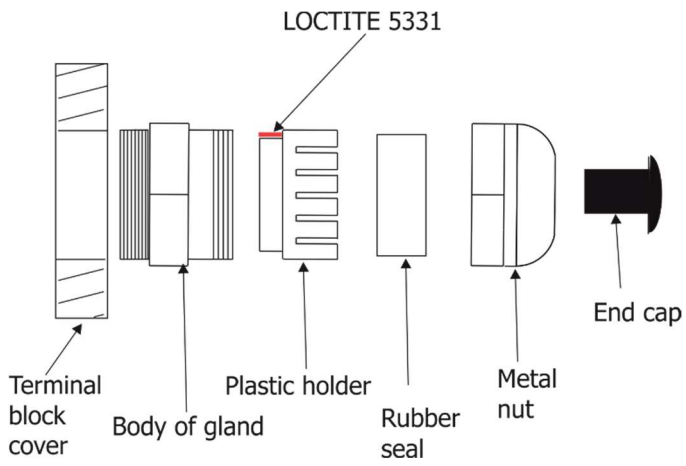

4. Screw the cover (2) back on the junction box.

4. Control and connection options

4.1 DMX or DALI

Example

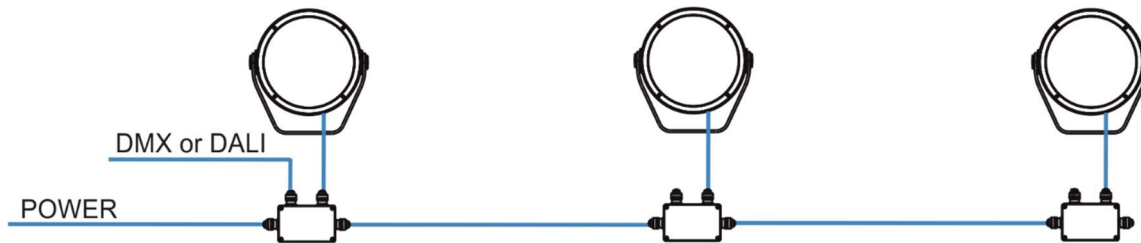

DMX connection (CE)

IF the 5-cored cable Flamar 3x AWG 16 + 1x (2x AWG 24), (P/N 1305 1508) is used for Calumma connection and connection among junction boxes:

Core	Connection	Core	Connection
Black	Live (L)	Red	Data + (+)
Blue	Neutral (N)	White	Data - (-)
Yellow/Green	GND ⊕	Shielding	Data ground (0V)

Up to 32 Calummas can be connected in DMX chain.

⚠ NOTE: DMX line of Calummas S has to be terminated at the last fixture. Connect a 120 Ohm resistor between terminals + and - in the junction box at fixture.

Example

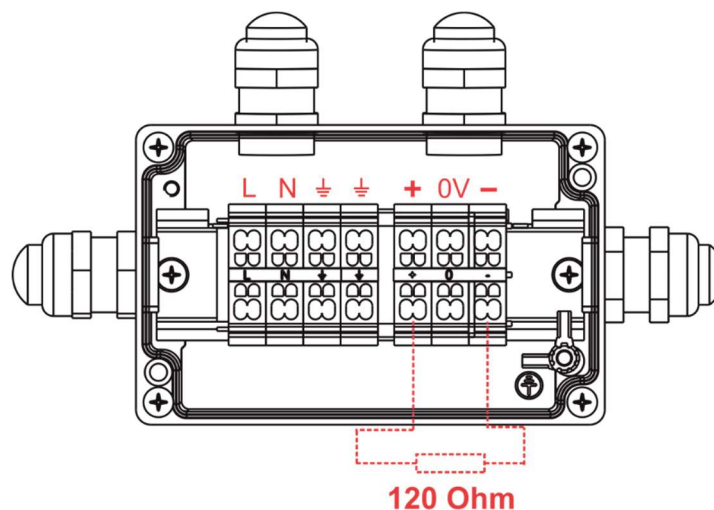

OR terminate via RDM Set the 'Manufacturer PID' 'Terminator active' to '1' at last fixture by means of RDM Control Panel.



Ensure **ONLY** the last fixture in the line is terminated using **ONE** of the above methods!

DALI connection (CE)

Cable 4BD51501-3core+DALI 5X1.5mm² Hybrid LSZH black (P/N 1305 3693) is intended for Calumma connection and connection among junction boxes.

DALI connection (US)

Cable SJTW 5x 14AWG (P/N 1305 3336) is intended for Calumma connection and connection among junction boxes.

Colors and connection stated in the table below go for both cables stated above.

Core	Connection	Core	Connection
Black	Live (L)	Red	Data
White	Neutral (N)	Orange	Data
Yellow/Green	GND ⊕		

Up to 64 Calummas can be connected in DALI network.

4.2 Power On/Off

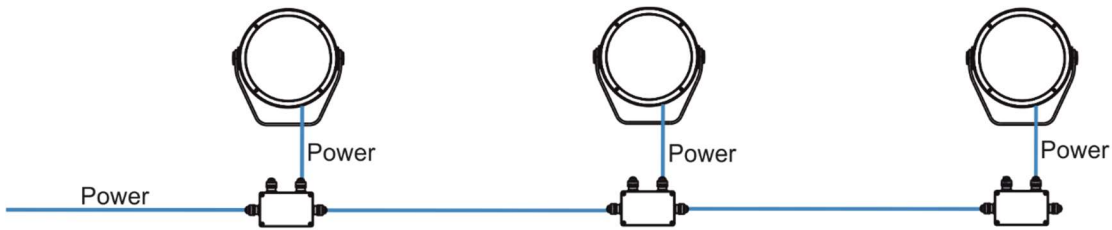

Note: This type of connection is available for single chip (SC) versions only – pure white or single colour. Non dimmable.

Input voltage: 120-277V

Power On/Off connection (CE)

3-cored cable H07BB-F 3G 1.5 (P/N 1305 1443)

Core	Connection
Brown	Live (L)
Light Blue	Neutral (N)
Yellow/Green	GND ⊕

Power On/Off connection (US)

3-cored cable SEOOW power 3x16 AWG (P/N 13051558-1)

Core	Connection
Black	Live (L)
White	Neutral (N)
Green	GND ⊕

4.3 DMX or Ethernet via E-box

Example with junction boxes

Pass Through mode is intended for this connection. Max. 32 fixtures can be connected to one LED output of the E-Box (Star, Daisy, Lite) in this mode.

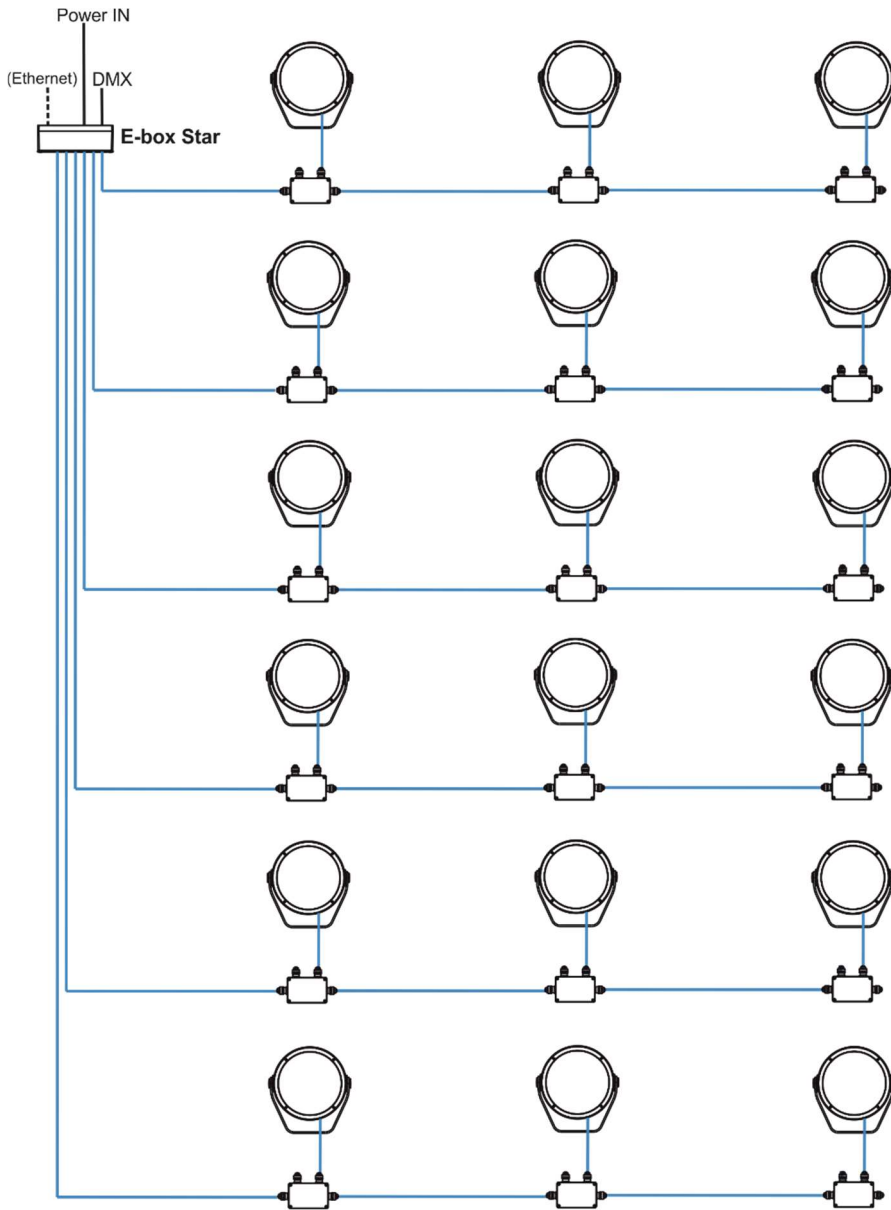

NOTE: DMX line of Calummas S on each output of the E-box has to be terminated at last fixture. Connect a 120 Ohm resistor between terminals + and - in the junction box at last fixture. Please see instructions in chapter 4.1 DMX or DALI.

Calumma S

CE version

IF the 5-cored cable Flamar 3x AWG 16 + 1x (2x AWG 24), (P/N 1305 1508) is used for Calumma connection and connection among junction boxes:

Core	Connection	Core	Connection
Black	Live (L)	Red	Data + (+)
Blue	Neutral (N)	White	Data – (-)
Yellow/Green	GND ⊕	Shielding	Data ground (0V)

US version

IF the 6-cored cable SJTW 6x 14AWG, (P/N 1305 3480) is used for Calumma connection and connection among junction boxes:

Core	Connection	Core	Connection
Black	Live (L)	Red	Data + (+)
White	Neutral (N)	Orange	Data – (-)
Yellow/Green	GND ⊕	Blue	Data ground (0V)

Number of connected Calummas to one E-box output depends on a cable length, power voltage, type of Calumma and E-box operation mode.

The tables below state max. theoretical number of Calummas connected to the one LED output of the E-box.

Table for Pass-Through mode of E-boxes.

Calumma S MC	Voltage			
	120V	190V	230V	277V
Cable length *				
10 m	32	32	32	32
20 m	32	32	32	32
30 m	32	32	32	32
50 m	26	32	32	32
70 m	18	32	32	32
100 m	13	32	32	32

Calumma S SC	Voltage			
	120V	190V	230V	277V
Cable length *				
10 m	32	32	32	32
20 m	32	32	32	32
30 m	32	32	32	32
50 m	26	32	32	32
70 m	18	32	32	32
100 m	13	32	32	32

Calumma S

* Cable length is a total cable length between power supply (e.g. E-box) and last connected Calumma.

Example: Total cable length=L1+L2+L3+L4+L5+L6

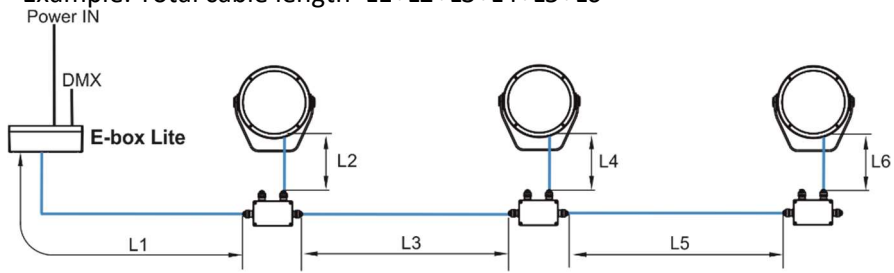

4.4 Example of Control panel in RDM manager

The software RDM manager is available on the ROBE website (<https://www.robe.cz/support>), product RUNIT WTX.

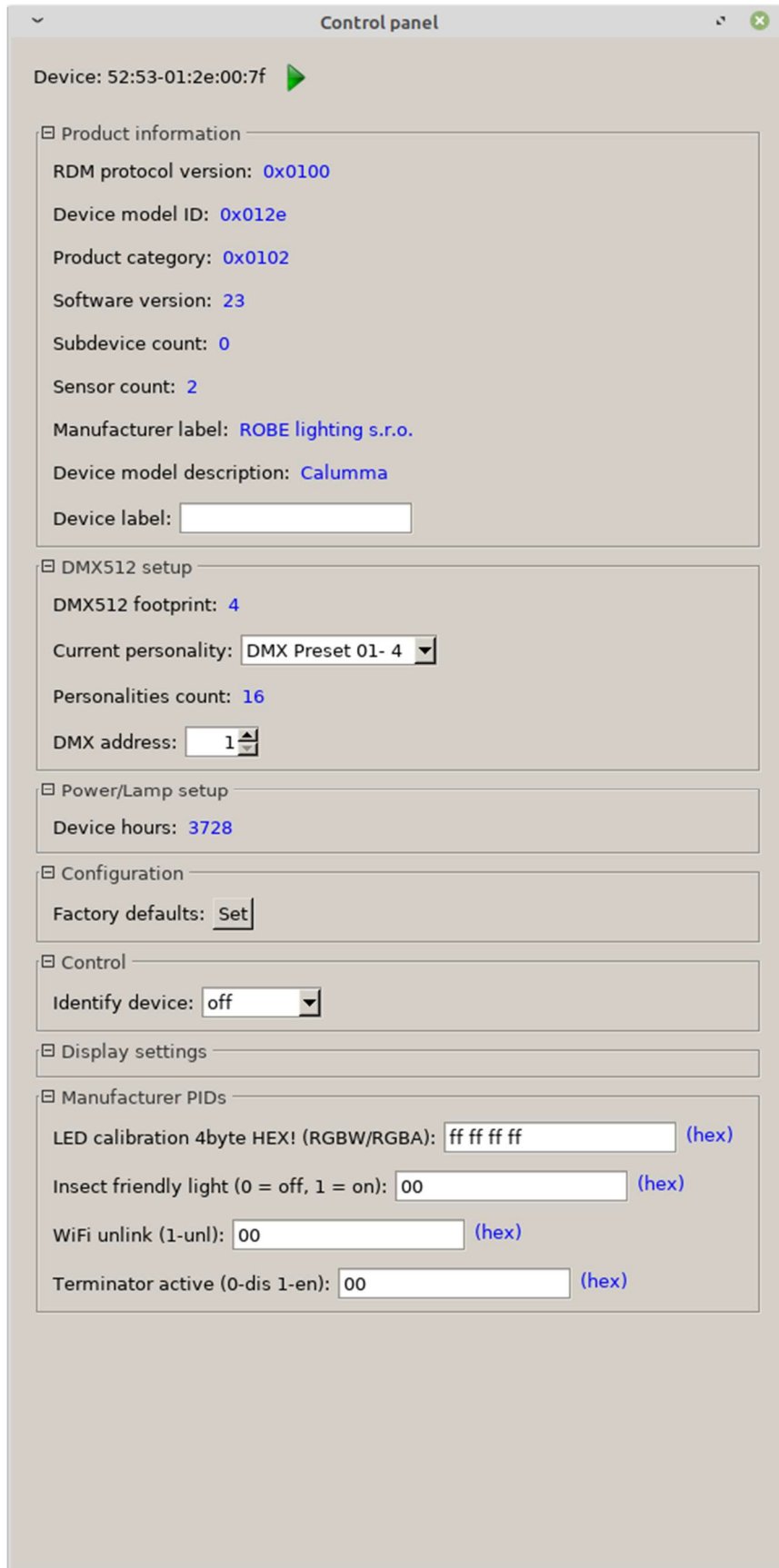

Green arrow  saves changes made in the Control panel to the Calumma.

Manufacturer PIDs

LED calibration 4byte HEX! (RGBW/RGBA) - the item shows 4 bytes of calibration values for calibrated white colours of RGBW(RGBA) Calumma.

E.g.



CTC channel has to be set to some calibrated white colour (21 DMX-1800K, 66 DMX-2700K, 91 DMX-3200K, 141 DMX-4200K, 211 DMX-5600K, 255 DMX-6500K) otherwise the item shows values "ff ff ff ff" (and calibration values cannot be saved to the Calumma).

Warning!

Changing and saving values in this item will affect calibrated white colour(s) of the Calumma .

Insect friendly light - the item effects RGBA Calumma only. If the item is on, blue colour is not used in calibrated white colours. This modification of white lights results in a smaller attraction of white light for insects (mosquitos, moths..). The function is also available from DMX chart (channel Special Function, range 7-10 DMX).

WiFi unlink - the item is inactive for Calumma S.

Terminator active - the item allows you to terminate line of Calummas.

5. Software update

Software update of Calumma S modules has to be done by means of the software ROBE Uploader running on PC. The ROBE Uploader is a software for automatized software update of ROBE fixtures. The ROBE Uploader switches Calummas S to the update mode automatically.

Please see <https://www.robe.cz/robe-uploader/> for more information.

The Calummas S have to be operated in the Pass-Through mode.

To update Calummas S including the E-box.

1. Update connected LED modules by means of the file Calumma.lib in the ROBE Uploader.
2. Set the E-box to the Standard mode and switch it off/on. Use the file EminereEbox.lib in the ROBE Uploader for software update of the E-box.
3. After updating the E-box, set the E-box to the Pass-Through mode and switch it off/on.

For more information about updating please see the E-box Lite/Daisy/Star user manual.

Note: Calummas S in DALI connection and ON/OFF connection cannot be updated.

Examples of connection:

1. By means of DMX connection and RUNIT. Connection via junction boxes.

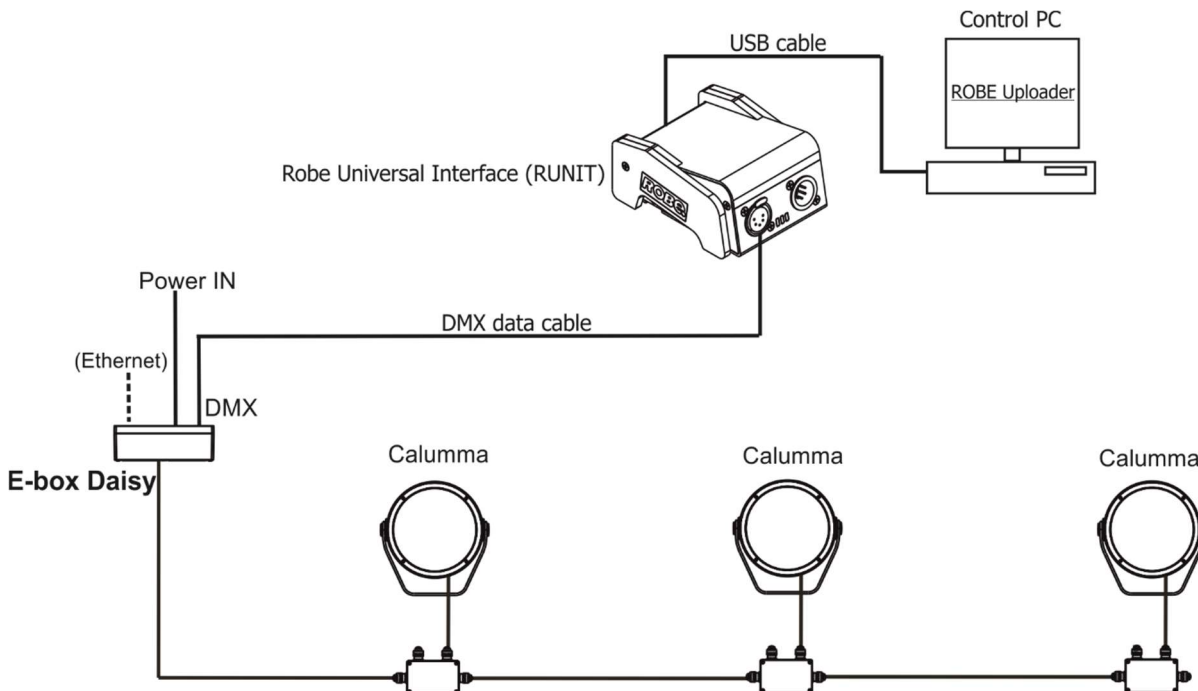

2. By means of the Ethernet connection. Connection via junction boxes.

Calumma S

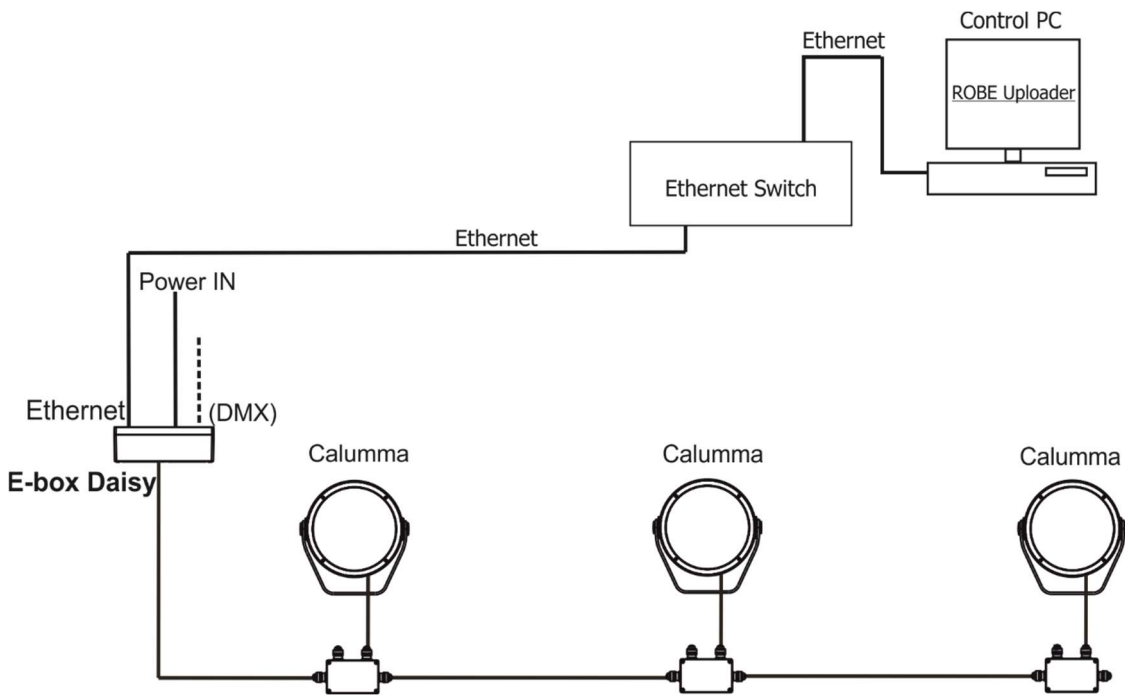

DMX connection

For updating of Calumma modules, use the file [Calumma.lib](#).

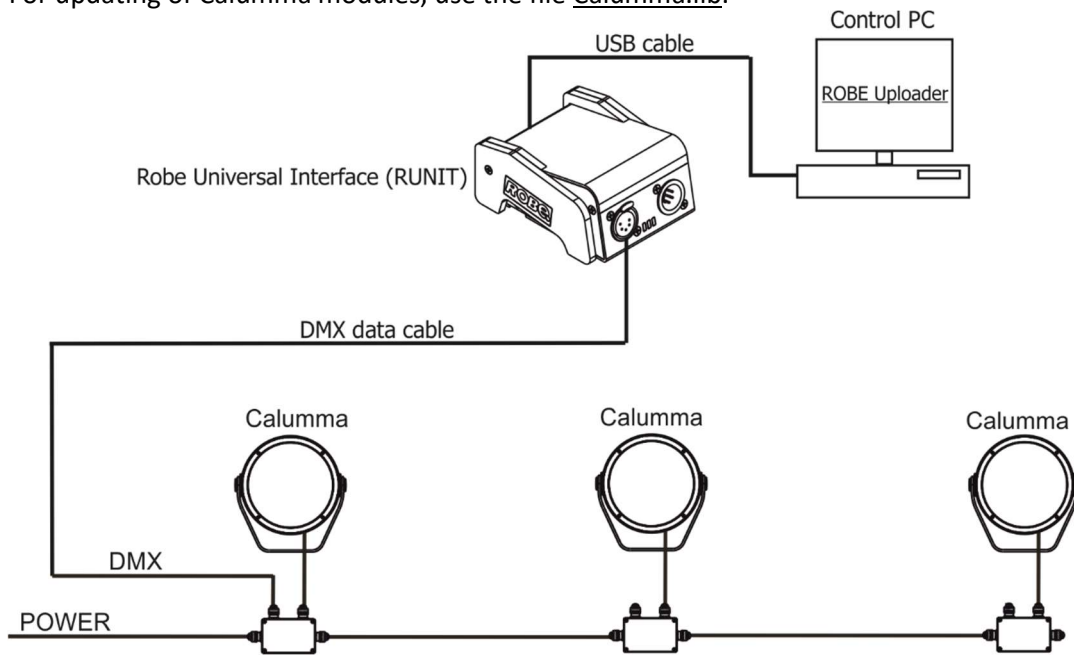

6. Technical specifications

Power supply

- Electronic auto-ranging
- Input voltage: 120 - 277V AC, 50/60 Hz
- Power consumption:
 - Calumma S MC: 30 W
 - Calumma S SC: 30 W
- Inrush current:
 - Calumma S MC: 60A/230VAC, 30A/115VAC
 - Calumma S SC: 60A/230VAC, 30A/115VAC

Optic

- Light source:
 - Calumma S MC: 3 x high power multichip LEDs
 - Calumma S SC: 19 x high power single chip LEDs
- Colour variants: RGBW (W - 6500 K), RGBA, PW (W - 3000 K)
- Beam Angle Calumma S MC:
 - Symetrical: 9°, 15°, 25°, 30°, 45°, 65°, 100°
 - Bi-symetrical: 10° x 30°, 30° x 10°, 10° x 60°, 60° x 10°, 15° x 45°, 45° x 15°, 15°x90°, 90°x15°, 30°x60°, 60°x30°, 30°x90°, 90°x30°
- Beam Angle Calumma S SC:
 - Symetrical: 10°, 15°, 25°, 30°, 45°, 65°, 100°
 - Bi-symetrical: 10° x 30°, 30° x 10°, 10° x 60°, 60° x 10°, 15° x 45°, 45° x 15°, 15°x90°, 90°x15°, 30°x60°, 60°x30°, 30°x90°, 90°x30°
 - Asymmetrical side, Asymmetrical forward
- Projected Lumen Maintenance: L90B10 >90.000 hrs, Ta = 25°C / 77°F

Compatible drivers

- E-box Daisy
 - 1 Output
 - 1 Main power Input
 - Control: DMX, Art-Net, sACN , W-DMX control, RDM
 - Pixel control
 - 120-277V Input
 - Connection via terminal blocks, inlets via grommet
 - IP67
- E-box Star
 - 6 outputs
 - 1 Main power Input
 - Control: DMX, Art-Net, sACN , W-DMX control, RDM
 - Pixel control
 - 120-277V Input
 - Connection via terminal blocks, inlets via grommet
 - IP67
- E-box Lite
 - 1 output
 - 1 Main power Input
 - Control: DMX, W-DMX control, RDM
 - Pixel control
 - 120-277V Input
 - Connection via screw terminal blocks, inlets via grommet
 - IP67

Mounting method

- Via yoke
- Adjustability: -180°/+180°

Housing

- High pressure die-cast aluminium body
- Tempered glass

Cooling system

- Convection

Total heat dissipation

- Calumma S MC: 77 BTU/h (calculated)
- Calumma S SC: 77 BTU/h (calculated)

Protection factor

- CE: IP 67 (IP 66 junction box)
- US: Suitable for wet location

Impact rating

- IK10

Operating ambient temperature range

- -20°C /+40°C (-4°F /+104°F)

Connection - CE

- DMX connection
Calumma IN: Flamar 3x AWG 16 + 1 x (2x AWG 24), Standard 1m with bare-end (P/N 1305 1508)
Interconnecting cables: Flamar 3x AWG 16 + 1 x (2x AWG 24) (P/N 1305 1508)
Junction box (P/N 1098 0714)
- DALI connection
Calumma IN: 4BD51501-3core+DALI 5X1.5mm² Hybrid LSZH black, standard 1m with bare-end (P/N 13053693)
Interconnecting cables: 4BD51501-3core+DALI 5X1.5mm² Hybrid LSZH black (P/N 1305 3693)
Junction box (P/N 1098 0714)
- DMX or Ethernet via E-box and Junction box
Calumma IN: Flamar 3x AWG 16 + 1x (2x AWG 24), standard 1m with bare-end (P/N 1305 1508)
Interconnecting cables: Flamar 3x AWG 16 + 1 x (2x AWG 24), (P/N 1305 1508)
Junction box (P/N 1098 0714)
- Power On/Off connection
Calumma IN: H07BB-F 3G1.5, standard 1m with bare-end (P/N 13051443)
Junction box (P/N 1098 0714)

Connection - US

- DALI connection
Calumma IN: SJTW 5x 14AWG, standard 1m with bare-end (P/N 1305 3336)
Interconnecting cables: SJTW 5x 14AWG (P/N 1305 3336)
Junction box (P/N 1098 0714)

Calumma S

- DMX or Ethernet via E-box and Junction box
Calumma IN: SJTW 6x 14AWG ,standard 1m with bare-end (P/N 1305 3480)
Interconnecting cables: SJTW 6x 14AWG ,(P/N 1305 3480)
Junction box (P/N 1098 0714)
- Power On/Off connection
Calumma IN: SEOOW power 3x16AWG, standard 1m with bare-end (P/N 13051558-1)
Junction box (P/N 1098 0714)

Weight

- Calumma S SC: 3.44 kg (7.6 lbs)
- Calumma S MC: 3.68 kg (8.11 lbs)

Calumma S

Dimensions (All dimensions in mm [inch])

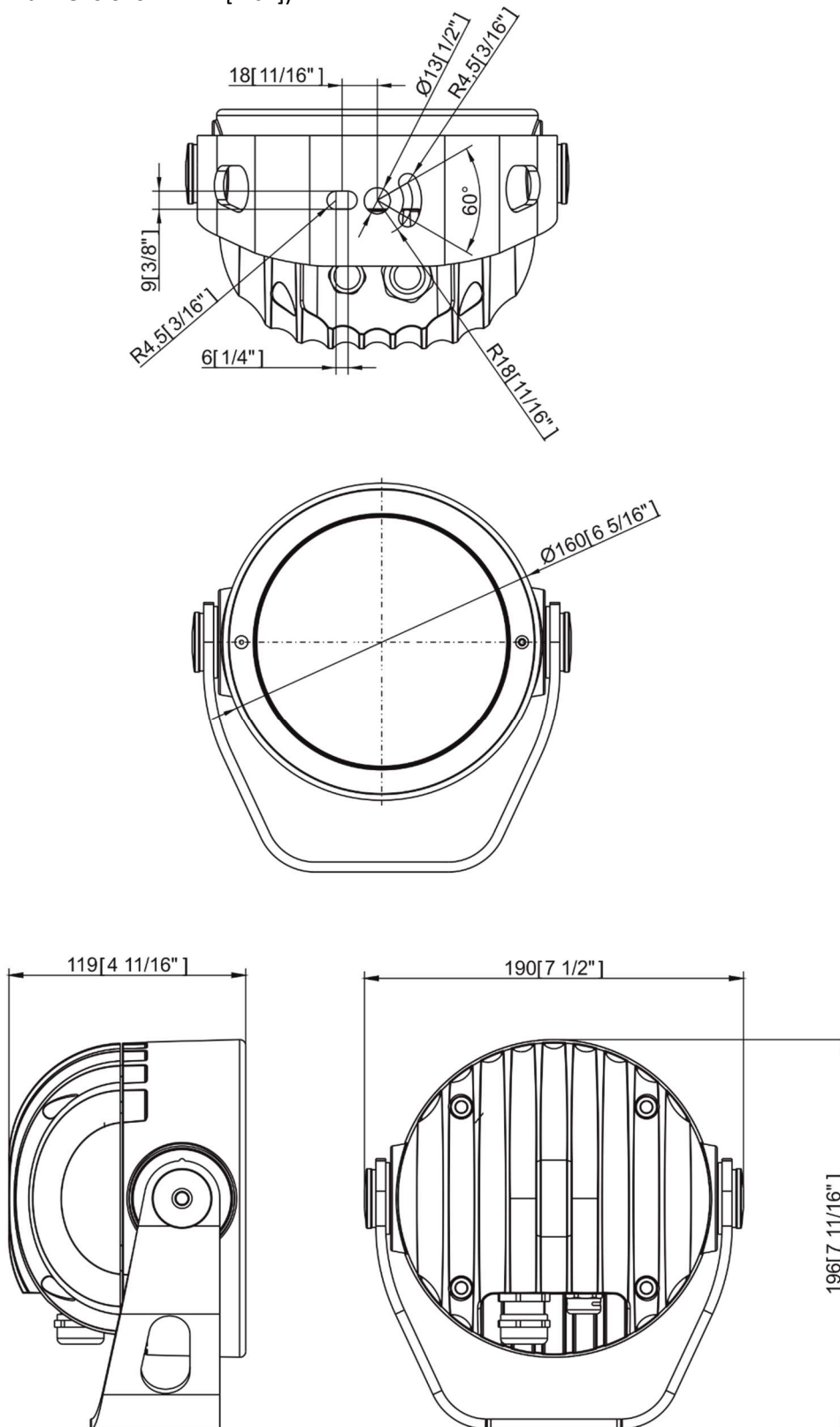

Calumma S with Pole clamp adaptor

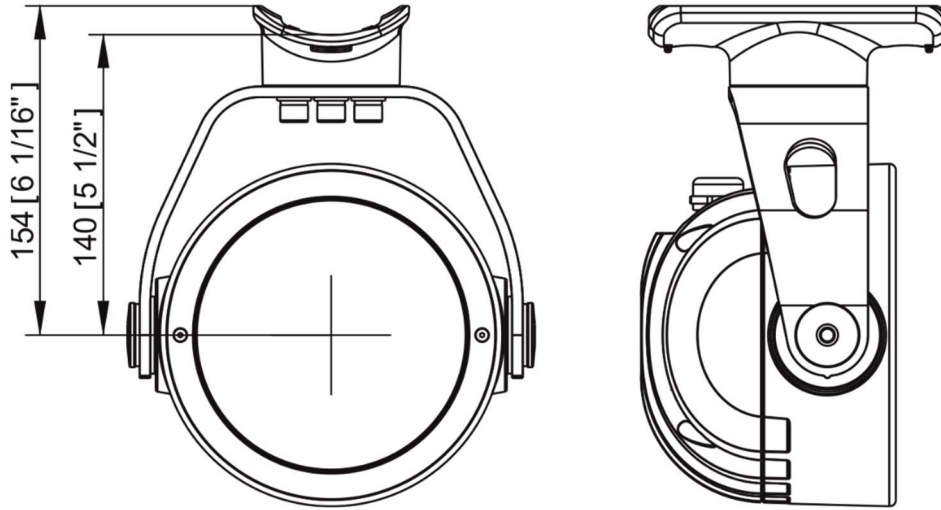

Pole clamp adaptor for Calumma

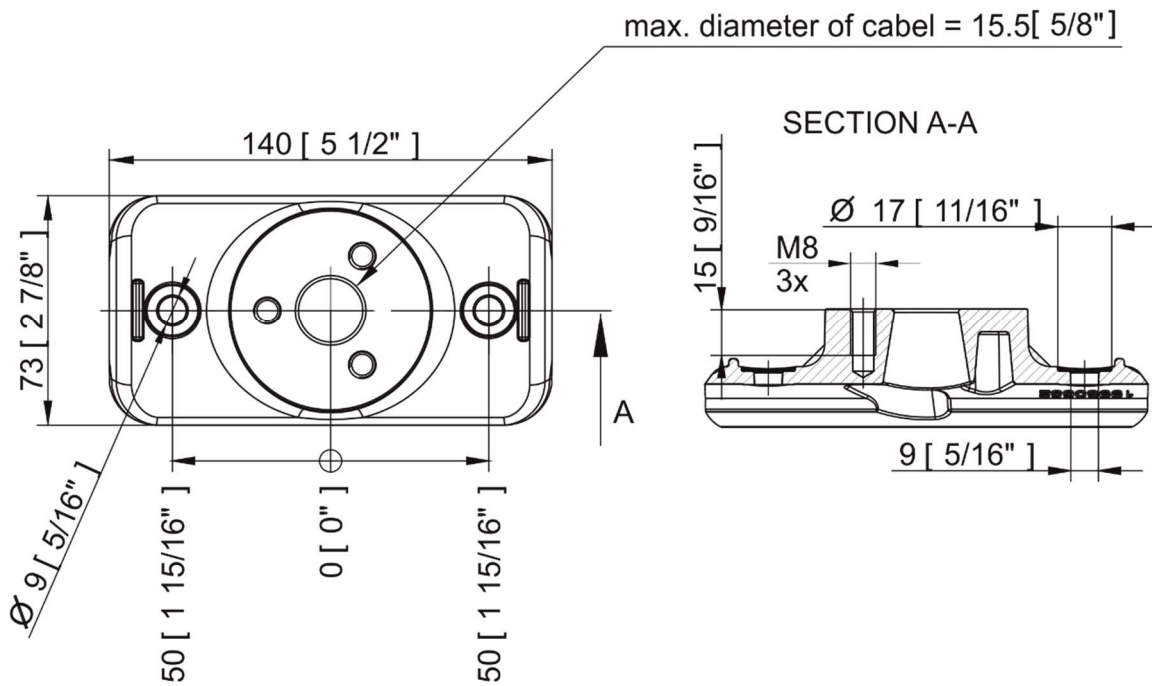
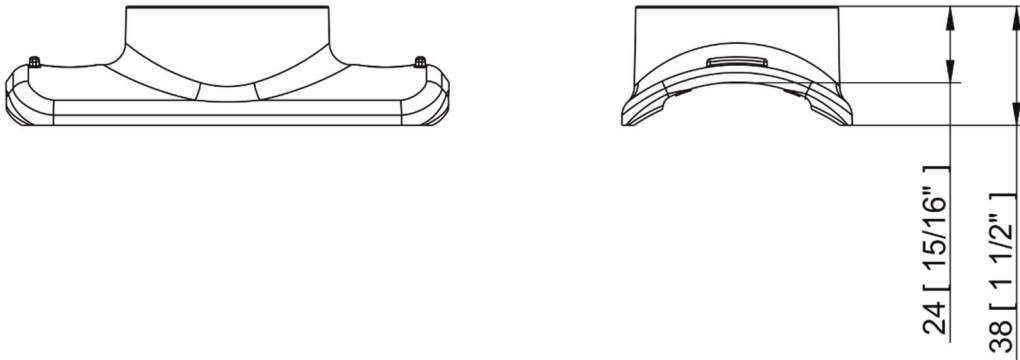

Calumma S

Junction box

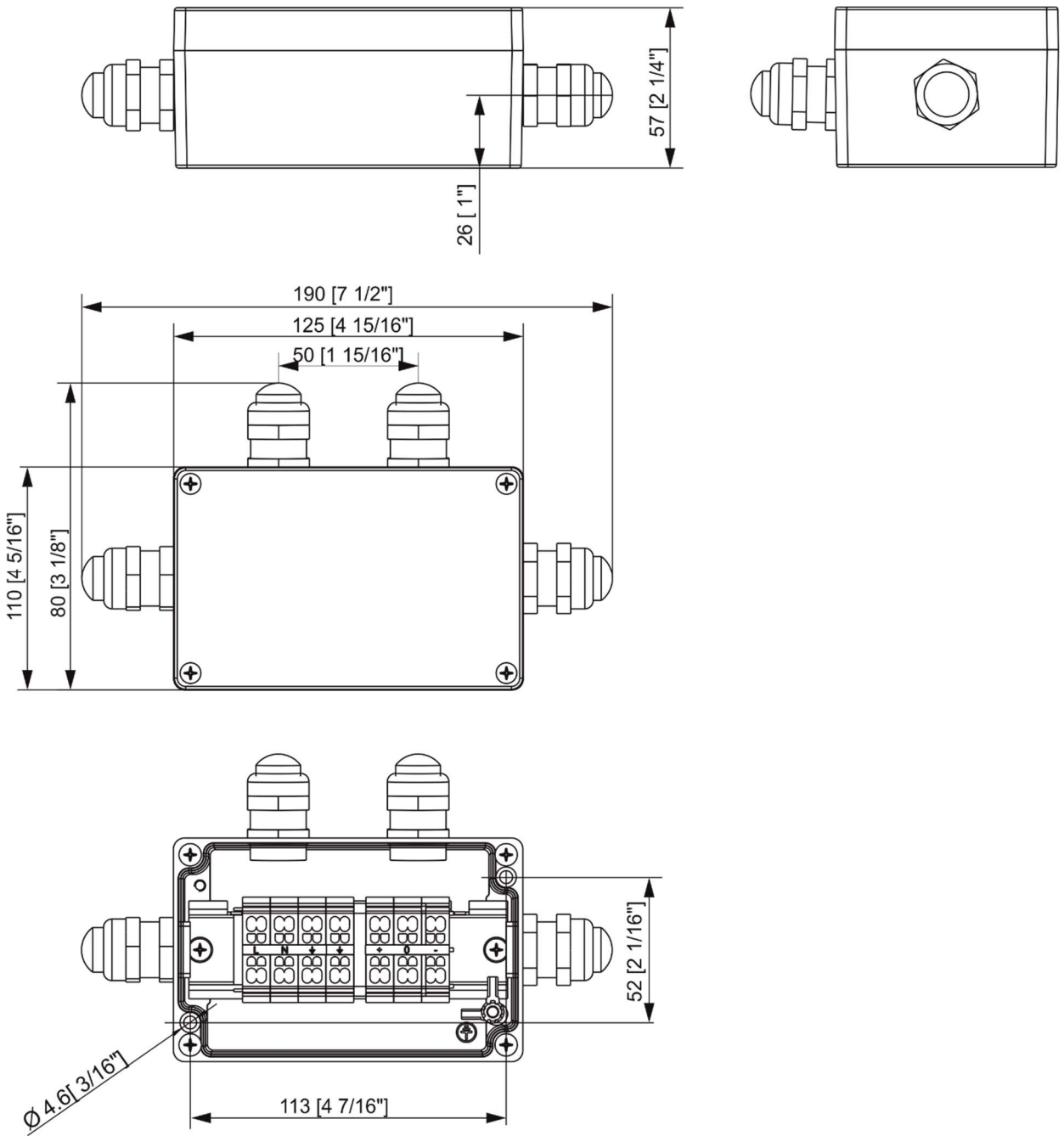

Land Spike

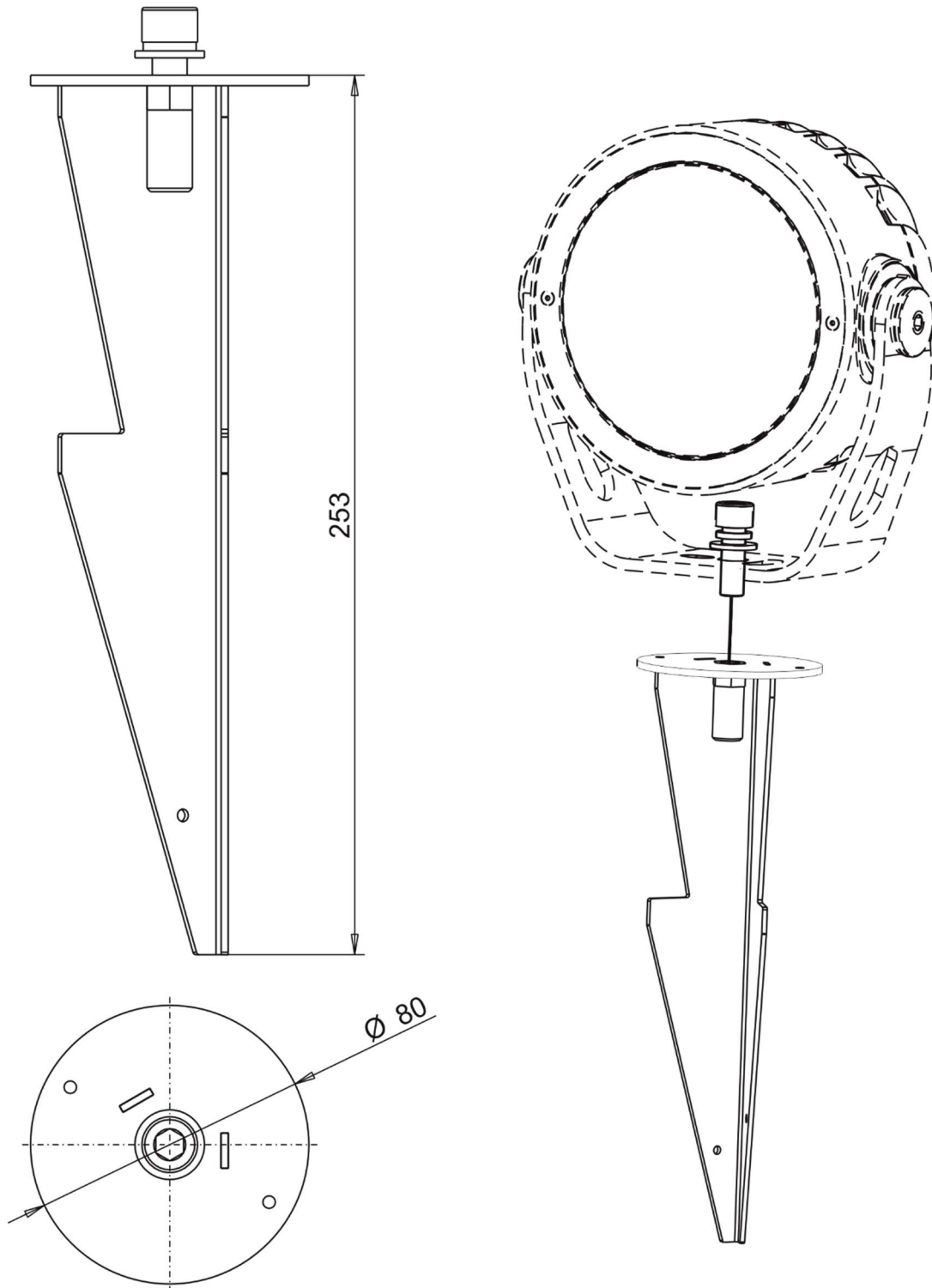

Included items

- 1 x Calumma S MC / Calumma S SC
- 1 x User manual

Optional accessories

Junction Box for Calumma, 1x Output, Ral 9006 (P/N 10980757)

Junction Box for Calumma, 1x Output, Ral 9011 (P/N 10980714)

Top Hat Calumma S RAL9011 (P/N 10980733)

Half Top Hat Calumma S RAL9011 (P/N 10980737)

Pole clamp adaptor for Calumma RAL 9011 (P/N 10980783)

Land Spike for Calumma S, M, L, XL (P/N 10981065)

Tenon Adaptor for Calumma S

Pole Mount Bracket for Calumma S

E-box Daisy (P/N 10063655)

E-box Daisy/W (P/N 10063638)

E-box Lite (P/N 10063657)

E-box Lite/W (P/N 10063653)

E-box Star (P/N 10063656)

E-box Star/W (P/N 10063644)

7. Cleaning and maintenance

DANGER !

Disconnect from the mains before starting any maintenance or cleaning work

Rinse off loose dirt with low pressure water spray. Wash the housing with a soft brush or sponge and a mild, non-abrasive washing detergent. Rinse it.

Maintenance and service operations are only to be carried out by a qualified person.

Should you need any spare parts, please use ROBE OEM parts.

7.1 Disposing of the product

To preserve the environment please dispose or recycle this product at the end of its life according to the local regulations and codes.

8. ChangeLog

This section summarizes changes in the user manual.

Version of manual	Date of issue	Description of changes
1.1	12/10/2022	DMX chart ver.1.1 added
1.2	05/01/2023	Software update description changed
1.3	10/02/2023	DMX chart ver. 1.2 added
1.4	17/02/2023	Pole adaptor for Calumma added
1.5	22/02/2023	Power ON/Off connection description changed
1.6	17/03/2023	EMC notes added
1.7	17/04/2023	DMX line termination added
1.8	11/05/2023	Dimensions of the fixture more specified
1.9	03/07/2023	On/Off version more specified
2.0	20/09/2023	New cabel for DALI connection (CE version)
2.1	23/01/2024	Control panel of RDM manager added, DMX chart ver. 1.3
2.2	17/06/2024	Land Spike added to optional accessories

Specifications are subject to change without notice.

June 17, 2024

Copyright © 2022-2024 Robe Lighting - All rights reserved

Made in CZECH REPUBLIC by ROBE LIGHTING s.r.o. Palackeho 416/20 CZ 75701 Valasske Mezirici

DMX protocol for Calumma - All sizes - MC and SC

Version: 1.3 (16 modes in total)

Mode/Channels in all								Mode 1- RGBW(A)-8bit, Mode 2- RGB 8-bit, Mode 3- full RGBW(A)	
1	2	3	4	5	6	7	8-10	Mode 4- White-full control, Mode 5- Reduced RGBW(A)	
4	3	12	3	6	8	15	Reserved	Mode 6- Reduced RGBW(A)+white control, Mode 7- Full control	
								Mode 7-Full RGBW(A)+virt. Colour wheel	
								RGBW/RGBA/RGB modes	
Mode/channels							DMX Value	Function	Type of control
1	2	3	4	5	6	7			
-	-	-	-	-	-	1		Special functions	
							0	No function <i>To activate following functions , stop in DMX value for at least 3 sec.</i>	step
							1-2	Save current DMX values to fixture as initial DMX values.	step
							3-4	Show saved initial DMX values	step
							5-6	Run factory demo sequences at switching fixture on (without DMX)	step
							7-8	Insect friendly light On (RGBA version only)	step
							9-10	Insect friendly light Off (RGBA version only)	step
							11-255	Reserved	
1	1	1	-	1	1	2		Red	
							0 - 255	Red LEDs saturation control (0-100%)	proportional
-	-	2	-	-	-	3		Red Fine	
							0 - 255	Red LEDs saturation control fine	proportional
2	2	3	-	2	2	4		Green	
							0 - 255	Green LEDs saturation control (0-100%)	proportional
-	-	4	-	-	-	5		Green Fine	
							0 - 255	Green LEDs saturation control fine	proportional
3	3	5	-	3	3	6		Blue	
							0 - 255	Blue LEDs saturation control (0-100%)	proportional
-	-	6	-	-	-	7		Blue Fine	
							0 - 255	Blue LEDs saturation control fine	proportional
4	-	7	-	4	4	8		White (Amber)	
							0 - 255	White LEDs saturation control (0-100%)	proportional
-	-	8	-	-	-	9		White (Amber) Fine	
							0 - 255	White LEDs saturation control fine	proportional
-	-	9	1	-	5	10		Green correction	
							0	Uncorrected white	step
							1-127	Minus green - uncorrected white	proportional
							128	Uncorrected white (128=default)	step
							129-255	Uncorrected white - Plus green	proportional
-	-	10	2	-	6	11		Colour temperature correction (CTC)	
							0	No function	step
							1 - 10	Tungsten dimming 2700 K	step
							11 - 20	Tungsten dimming 3200 K	step
							21-255	Colour temperature changing from 1800 K --> 6500 K (21-1800K, 66-2700K, 91-3200K,141-4200K, 211-5600K, 255-6500K)	proportional
-	-	-	-	-	-	12		Virtual Colour Wheel	
							0	No function	step

DMX protocol

Mode/channels							DMX Value	Function	Type of control
1	2	3	4	5	6	7			
							1-2	White 1800 K	step
							3-4	White 2700 K	step
							5-6	White 3200 K	step
							7-8	White 4200 K	step
							9-10	White 5600 K	step
							11-12	White 6500 K	step
							13	Blue (Blue=full, Red+Green+White/Amber=0)	step
							14-23	Red=0, Green->up,Blue =full, White/Amber=0	proportional
							24	Cyan (Red=0, Green=full, Blue =full, White/Amber=0)	step
							25-34	Red=0, Green=full, Blue->down, White/Amber=0	proportional
							35	Green (Red=0, Green=full, Blue =0, White/Amber=0)	step
							36-45	Red->up, Green=full, Blue=0, White/Amber=0	proportional
							46	Yellow (Red=full, Green=full, Blue=0, White/Amber=0)	step
							47-56	Red=full, Green->down, Blue=0, White/Amber=0	proportional
							57	Red(Red=full, Green=0, Blue=0, White/Amber=0)	step
							58-67	Red=full, Green=0, Blue->up, White/Amber=0	proportional
							68	Magenta (Red=full, Green=0, Blue=full, White/Amber=0)	step
							69-78	Red -> down, Green=0, Blue=full, White/Amber=0	proportional
							79	Blue (Red=0, Green=0, Blue=full, White/Amber=0)	step
								Transition effects	
							80-87	Rainbow effect (with fade time) from slow-> fast	proportional
							88-95	Rainbow effect (without fade time) from slow-> fast	proportional
							96-103	Full dynamic white (1800K->6500K->1800K) (with fade time) from slow-> fast	proportional
							104-111	Full dynamic white (1800K->6500K->1800K) (without fade time) from slow-> fast	proportional
							112-119	Dynamic warm white (1800K-3000K-1800K) (with fade time) from slow-> fast	proportional
							120-127	Dynamic warm white (1800K-3000K-1800K) (without fade time) from slow-> fast	proportional
							128-135	Rainbow effect + full dynamic white (with fade time) from slow-> fast	proportional
							136-143	Rainbow effect + full dynamic white (without fade time) from slow-> fast	proportional
							144-151	Blue/Green effect (with fade time) from slow-> fast	proportional
							152-159	Blue/Green effect (without fade time) from slow-> fast	proportional
							160-167	Red/Blue effect (with fade time) from slow-> fast	proportional
							168-175	Red/Blue effect (without fade time) from slow-> fast	proportional
							176-183	Green/Red effect (with fade time) from slow-> fast	proportional
							184-191	Green/Red effect (without fade time) from slow-> fast	proportional
							192-199	Blue/4000K effect (with fade time) from slow-> fast	proportional
							200-207	Blue/4000K effect (without fade time) from slow-> fast	proportional
							208-215	Green/4000K effect (with fade time) from slow-> fast	proportional
							216-223	Green/4000K effect (without fade time) from slow-> fast	proportional
							224-231	Red/4000K effect (with fade time) from slow-> fast	proportional
							232-239	Red/4000K effect (without fade time) from slow-> fast	proportional
						13		Shutter/Strobe	
							0-31	Shutter closed	step
							32-63	Shutter open	step
							64-95	Strobe-effect from slow to fast	proportional

DMX protocol

Mode/channels							DMX Value	Function	Type of control
1	2	3	4	5	6	7			
							96-127	Shutter open	step
							128-143	Opening pulse in sequences from slow to fast	proportional
							144-159	Closing pulse in sequences from fast to slow	proportional
							160-191	Shutter open	step
							192-223	Random strobe-effect from slow to fast	proportional
							224-255	Shutter open	step
-	-	11	3	5	7	14		Dimmer	
							0 - 255	Light intensity coarse (0-100%)	proportional
-	-	12	-	6	8	15		Dimmer Fine	
							0 - 255	Light intensity fine	proportional
Copyright © 2022-2024 Robe Lighting s.r.o. - All rights reserved									
All Specifications subject to change without notice									

DMX protocol for Calumma - All sizes - MC and SC					
Version: 1.3 (16 modes in total)					
Mode/Channels in all				TW Modes: Mode 11- White selection + Dimmer, Mode 12- WW + CW	
11	12	13	14-16	PW Mode: Mode 13- Dimmer	
3	4	2	Reserved		
TW and PW modes					
Mode/channels			DMX Value	Function	Type of control
11	12	13			
1	-	-	0 - 255	White colour selection White from 2700 K - 6500 K	proportional
-	1	-	0 - 255	Warm White Warm White LEDs saturation control (0-100%)	proportional
-	2	-	0 - 255	Cool White Cool White LEDs saturation control (0-100%)	proportional
2	3	1	0 - 255	Dimmer Light intensity coarse (0 - 100%)	proportional
3	4	2	0 - 255	Dimmer Fine Light intensity fine	proportional
Copyright © 2022-2024 Robe Lighting s.r.o. - All rights reserved					
All Specifications subject to change without notice					