

CALUMMA™ M MC

Featuring an optical design using 7 high efficacy multi-chip LEDs and available with optional LED colour variants and various beam angles, the medium-sized Calumma M MC luminaire creates powerful and beautiful light output for a spot, accent or flood lighting solution. Its durable housing is built to withstand any exterior conditions, and its special finish for harsh and marine environments provides an exceptional outdoor LED luminaire in an elegant design. Additionally, Calumma M MC can be connected in long In/Out daisy-chains via an E-Box and hybrid Plug & Play connections for almost effortless installation. Complemented by wide range of accessories and control protocols, this luminaire is an effective and versatile unit to get the most out of architectural lighting applications.



KEY FEATURES

Lumen output & Light source

Luminaire with seven high-power, multi-chip LEDs provides up to 2316 lumen output. Multiple LED colour variants. No light spills. Perfectly homogenised light output with efficacy up to 35 lm/w.

Design & Durability

Compact, durable and stylish housing made of high-pressure die cast aluminium. IP67 and IK10 certification; suitable for marine applications (Harsh Environment Finish required) and traffic applications. Supported with a 5 year warranty.

Flexibility

Exceptional outdoor or indoor LED luminaire with a wide range of accessories, custom colour finishes, multiple light output variants and beam angles.

Connectivity

Utilising the innovative E-Box series of power and data interfaces, Calumma M MC can communicate via numerous wired, wireless, and Ethernet based control protocols. Various wiring topologies are supported using hybrid power / data cables with Plug & Play connectors or standard connection options.

COLOURS

* UPON REQUEST



COLOUR TEMPERATURE

* UPON REQUEST

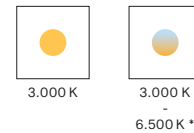

CONTROL & PROTOCOLS



OPTIC OPTIONS

SYMMETRICAL

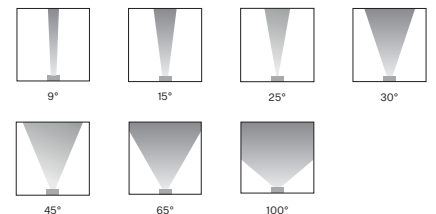

BI-SYMMETRICAL

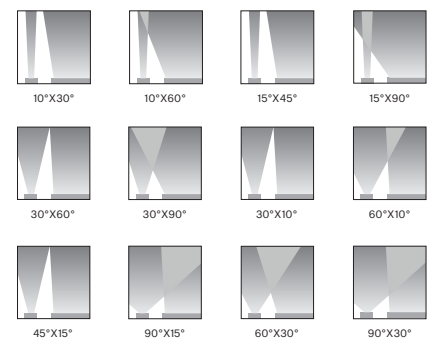

STANDARD & SPECIFICATION

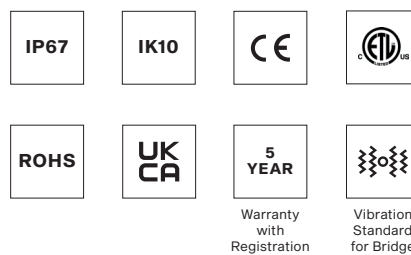

FINISH OPTIONS



CALUMMA M MC SPECIFICATION

ELECTRICAL	Input Voltage	120 - 277 V AC 50/60 Hz (US)	
	Typical Power Consumption	65 W +/-10 %	
OPTICAL	Light Source	High Power Multichip LEDs	
	Colour Variants	RGBW (W - 6500 K) RGBA PW (W - 3000 K) Other Variants On Request (TW 3000 - 6500 K)	
	Beam Angle	9° 15° 25° 30° 45° 65° 100° 10°x30° 30°x10° 10°x60° 60°x10° 15°x45° 45°x15° 15°x90° 90°x15° 30°x60° 60°x30° 30°x90° 90°x30°	
	Lumen Output Delivered	2316 lm (@9° RGBW)	
	Projected Lumen Maintenance	L90B10 >90.000 hrs, Ta = 25°C / 77°F	
	CONTROL	Interface Protocol	Via E-box range, DMX/RDM, wireless DMX, DALI 2
E-box control protocol		USITT DMX512+RDM, ArtNet, MA Net, MA Net2, sACN, Kling-Net	
DALI 2 Device Type		DT 8	
Wireless DMX (Option)		Lumen Radio CRMX Technology	
Control System		Third Party DMX Controllers	
Operating Modes		DMX, Stand-alone	
Settings / Addressing		E-box, RDM communicator	
Power Supply		Integrated	
PHYSICAL	Width x Height x Depth	264 x 278 x 106 mm (10.4 x 10.94 x 4.17 in.)	
	Weight	5.77 kg 12.72 lbs	
	Housing	High Pressure Die-Cast Aluminium Body Tempered Glass	
	Finish Options	Standard Colour - Graphite Black (RAL 9011), Silver (RAL 9006) Cost Option - Custom RAL Harsh Environment (RAL 9016, RAL 9011)	
	Cables / Connections	IN/OUT (for E-Box version): - 0,5 m cables with hybrid connectors - Jumper cables	IN (for DMX, DALI): - 1 m cable with bare end - Other cable length - custom - Junction box - optional
	Mounting Method	Yoke or Yoke for Pole Adaptor	
	Adjustability	+180° / -180°	
	Protection Factor	IP67 / Suitable For Wet Locations	
	IK Rating	IK10	
	Operating Ambient Temperature	-20 °C / +50 °C (-4 °F / +122 °F)	
CERTIFICATION	Listings	ETL / cETL, CE, RoHS, UKCA	
	Not Included Items		
ACCESSORIES		Junction Box for Calumma	
		Optical Demo Set for Calumma M (for demo purposes)	
		Outdoor Foil Holder for Calumma M (for permanent installation)	
		Optical Foil Set for Outdoor Foil Holder Calumma M	
		Land Spike for Calumma M	
		Top Hat Calumma M	
		Half Top Hat Calumma M	
		Tenon Adaptor for Calumma M	
		Floor Stand for Calumma S, M	
		Pole Adaptor (ø 102mm) (Yoke for Pole Adaptor Required)	

PROJECTED AREA

	Front (rear) - m ²	Front (rear) ft ²	Side - m ²	Side - ft ²	Top - m ²	Top - ft ²
Calumma Remote M	0,047	0,500	0,026	0,280	0,024	0,258
with Top Hat	0,047	0,500	0,054	0,581	0,052	0,559
with Half Top Hat	0,047	0,500	0,037	0,398	0,052	0,559

DIMENSIONS

Standard Yoke

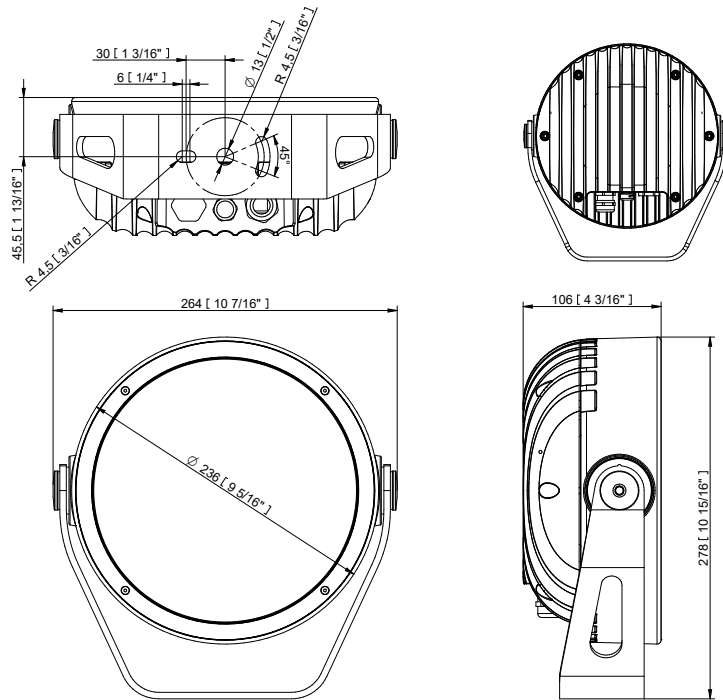

Yoke for Pole Adaptor (with Pole Adaptor / PA)

Example of ordering code: Calumma M MC RGBCW 15° PA

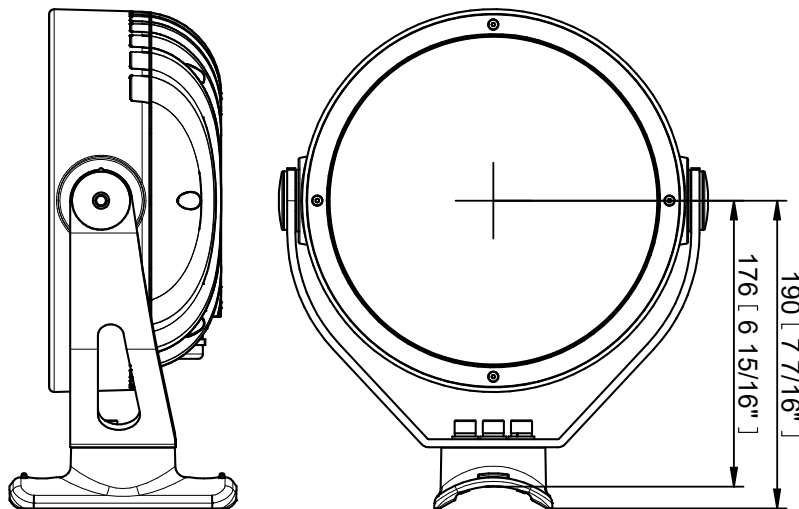

CONTROL AND CONNECTION OPTIONS - CE

DALI

- 1) Hybrid Cable (1305 3693)
Standard 1 m with bare-end
- 2) Hybrid Cable (1305 3693)
or
Scope of Others
- 3) Junction Box for Calumma

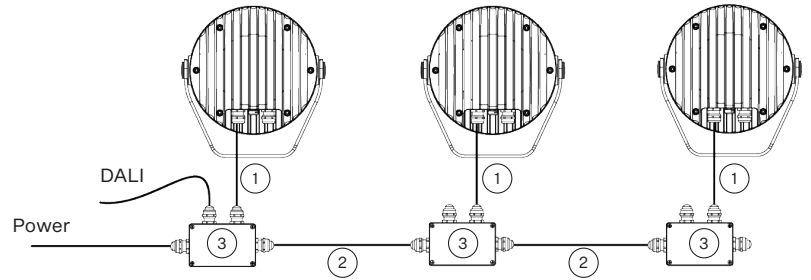

DMX

- 1) Flamar 3x AWG 16 + 1 x (2x AWG 24)
Standard 1 m with bare-end, (13051508), black
or
Hybrid Cable HYB-5731ZH LSZH (13053694), white
- 2) Flamar 3x AWG 16 + 1 x (2x AWG 24), (13051508), black
or
Hybrid Cable HYB-5731ZH LSZH (13053694) white
or
Scope of Others
- 3) Junction Box for Calumma

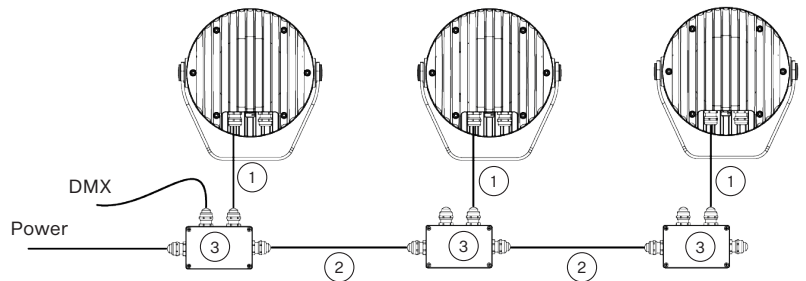

WIRELESS DMX

- 1) Flamar 3x AWG 16 + 1x (2x AWG 24),
(13051508), Standard 1 m bare-end, black
or
Hybrid Cable HYB-5731ZH LSZH (13053694), white
- 2) Junction Box for Calumma

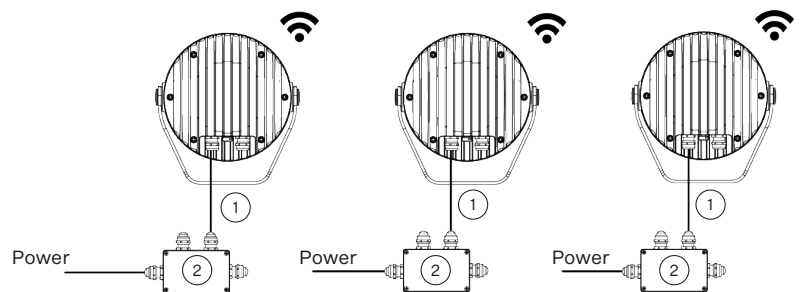

Note: This type of connection is available for M, L, XL versions.

- 1) Flamar 3x AWG 16 + 1x (2x AWG 24)
(13051508), Standard 1 m bare-end, black
or
Hybrid Cable HYB-5731ZH LSZH (13053694), white
- 2) Junction Box for Calumma
- 3) Flamar 3x AWG 16 + 1 x (2x AWG 24), (13051508)
or
Hybrid Cable HYB-5731ZH LSZH (13053694), white
or
Scope of Others

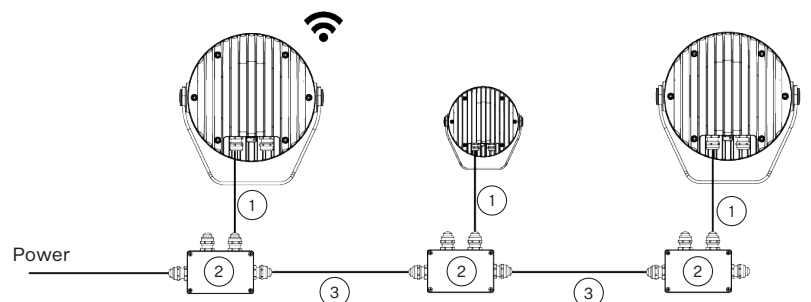

Note: This type of connection must have M, L or XL versions as the first luminaire. Next luminaires in a row could be chosen from S, M, L or XL versions.

CONTROL AND CONNECTION OPTIONS - CE

DMX or ETHERNET via E-BOX

- 1) Flamar 3x AWG 16 + 1x (2x AWG 24) (13051508), Standard 1 m with bare-end, black or Hybrid Cable HYB-5731ZH LSZH (13053694), white
- 2) Junction Box for Calumma
- 3) Flamar 3x AWG 16 + 1x (2x AWG 24), (13051508), black or Hybrid Cable HYB-5731ZH LSZH (13053694) white or Scope of Others

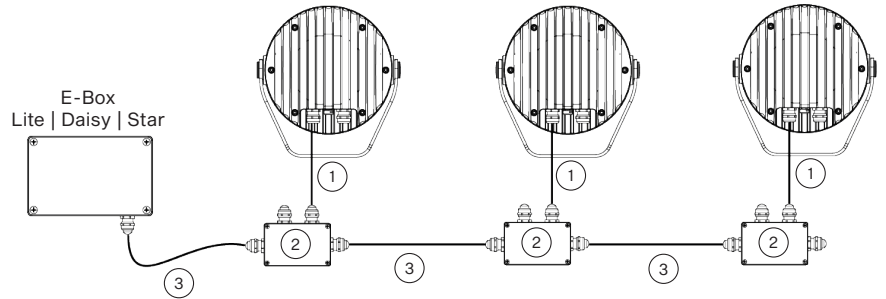

Note: This type of connection is available for S, M, L, and XL versions. E-Box has to be in Pass Through mode only.

- 1) Leader Cable MM (13053493) Standard 0,5 m with hybrid connector
- 2) Leader Cable MF (13053494) Standard 0,5 m with hybrid connector
- 3) Leader Cable FF 2 m (13053438)
Leader Cable FF 5 m (13053440)
Leader Cable FF 10 m (13053436)
Leader Cable FF 25 m (13053437)
Leader Cable FF 50 m (13053439)

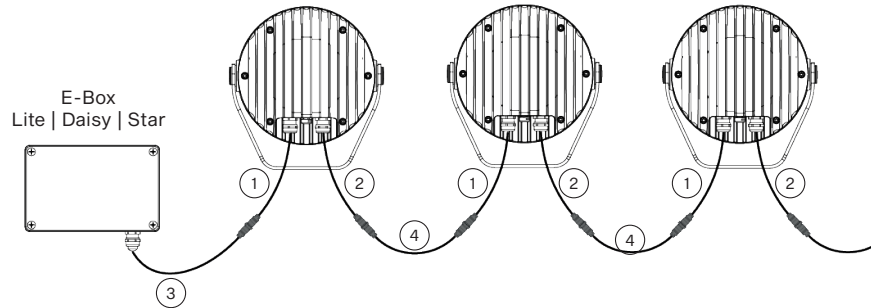

- 4) Jumper Cable FF/FM 0,25 m (13053422)
Jumper Cable FF/FM 0,5 m (13053423)
Jumper Cable FF/FM 1 m (13053425)
Jumper Cable FF/FM 2 m (13053427)
Jumper Cable FF/FM 3 m (13053428)
Jumper Cable FF/FM 5 m (13053430)
Jumper Cable FF/FM 10 m (13053424)

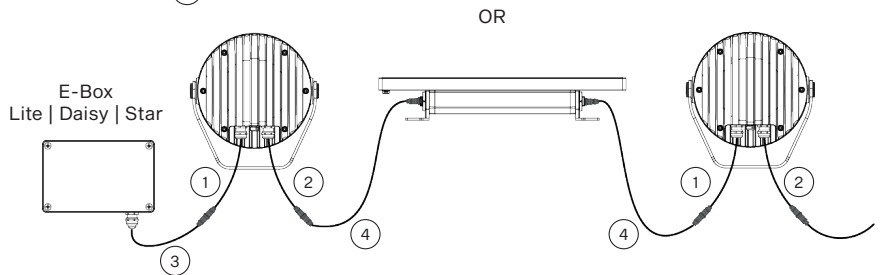

Note: With this type of connection is possible to connect Calumma (M, L, XL) and Eminere (Eminere, Eminere Side) luminaires in a row.

CONTROL AND CONNECTION OPTIONS - US

DALI

- 1) SJTW 5x 14AWG (13053336), Standard 1 m with bare-end, black
or
Cable SJTW 5x 14AWG (13053697), white
- 2) SJTW 5x 14AWG (13053336), black
or
Cable SJTW 5x 14AWG (13053697), white
or
Scope of Others
- 3) Junction Box for Calumma

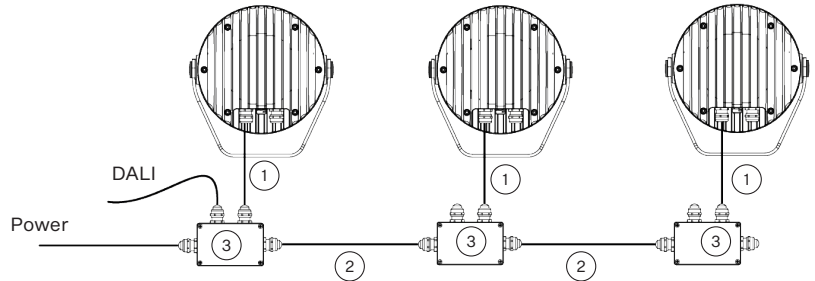

WIRELESS DMX

- 1) SJTW 6x 14AWG (13053480), Standard 1 m with bare-end, black
or
Cable SJTW 6x 14AWG (13053695), white
- 2) Junction Box for Calumma

Note: This type of connection is available for M, L, XL versions

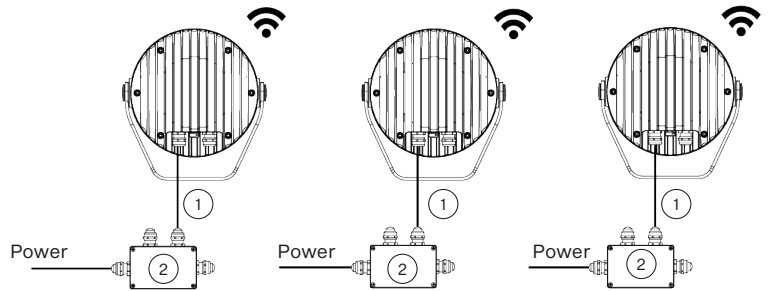

- 1) SJTW 6x 14AWG (13053480), Standard 1 m with bare-end, black
or
Cable SJTW 6x 14AWG (13053695), white
- 2) Junction Box for Calumma
- 3) SJTW 6x 14AWG (13053480), black
or
Cable SJTW 6x 14AWG (13053695), white
or
Scope of Others

Note: This type of connection must have M, L or XL versions as the first luminaire. Next luminaires in a row could be chosen from S, M, L or XL versions.

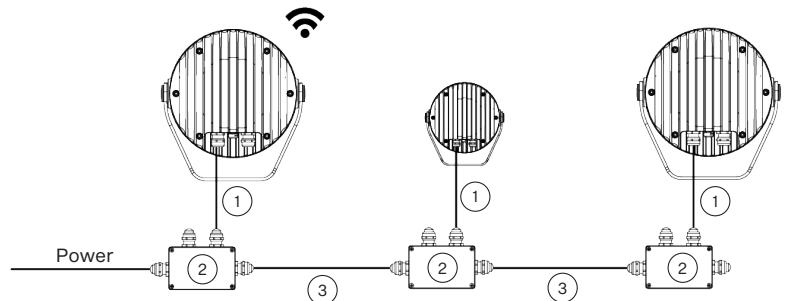

CONTROL AND CONNECTION OPTIONS - US

DMX or ETHERNET via E-BOX

- 1) SJTW 6x 14AWG (13053480)
Standard 1 m with bare-end, black
or
Cable SJTW 6x 14AWG (13053695), white
- 2) Junction Box for Calumma
- 3) SJTW 6x 14AWG (13053480), black
or
Cable SJTW 6x 14AWG (13053695), white
or
Scope of Others

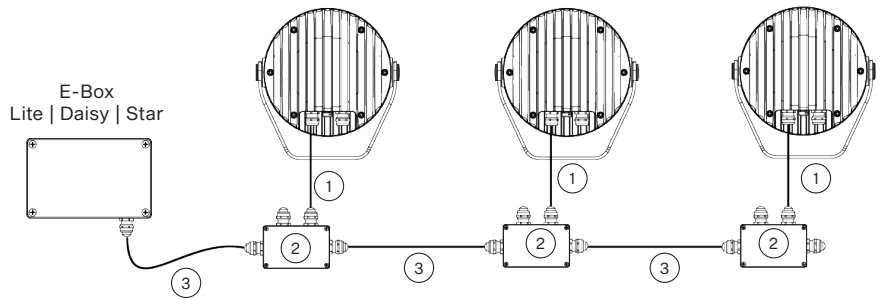

Note: This type of connection is available for S, M, L, and XL versions. E-Box has to be in Pass Through mode only.

CONNECTIVITY

Following table shows maximum connected Calummas M MC in a row with respect of cable length.

STANDARD MODE	Cable length (m)	Voltage (V)			
		120	190	230	277
CALUMMA M MC	10	28	44	54	65
	20	28	44	54	65
	30	20	44	54	65
	50	12	30	43	63
	70	8	21	31	45
	100	6	15	22	32
	200	3	7	11	16
	500	1	3	4	6

PASS-THROUGH MODE	Cable length (m)	Voltage (V)			
		120	190	230	277
CALUMMA M MC	10	28	32	32	32
	20	28	32	32	32
	30	20	32	32	32
	50	12	30	32	32
	70	8	21	31	32
	100	6	15	22	32

BOOSTER BOX POSITIONS

	Cable length (m)	Max. number of Calummas M MC= 191 (in Standard mode)			
		120 V	190 V	230 V	277 V
CALUMMA M MC	10 m	28	-	-	-
	20 m	28, 56	44	54	65
	30 m	20, 40, 60, 80, 100	44, 88	54, 108	65
	50 m	12, 24, 48, 56, 64, 76, 88, 100..	30, 60, 90, 120, 150, 180	43, 86, 129, 172	63, 126
	70 m	8, 16, 24, 32, 40, 48, 56, 64, 72, 80, 88, 96....	21, 42, 63, 84, 105, 126...	31, 62, 93, 124, 155, 176...	45, 90, 135, 180, 225...
	100 m	6, 12, 18, 24, 30, 36, 42, 48, 54, 60, 66, 72, 78, 84, 90, 96, 102....	15, 30, 45, 60, 75, 90, 105, 120, 135...	22, 44, 66, 88, 110, 132, 154...	32, 64, 96, 128, 160, 192
	200 m	3, 6, 9, 12, 15, 18, 21, 24, 27, 30, 33, 36, 39, 42, 45, 48, 51, 54, 57, 60, 63, 66, 69, 72, 75, 78, 81...	7, 14, 21, 28, 35, 42, 49, 56, 63, 70, 77, 84, 91, 98, 105...	11, 22, 33, 44, 55, 66, 77, 88, 99, 110...	16, 32, 48, 64, 80, 96, 112, 128, 144...
	500 m	1, 2, 3, 4, 5, 6, 7, 8, 9, 10, 11...	3, 6, 9, 12, 15, 18, 21, 24, 27, 30, 33, 36, 39, 42, 45, 48, 51, 54, 57, 60, 63, 66...	4, 8, 12, 16, 20, 24, 28, 32, 36, 40, 44, 48, 52, 56, 60, 64, 68, 72, 76, 80....	6, 12, 18, 24, 30, 36, 42, 48, 54, 60, 66, 72, 78, 84, 90, 96...

NOTE: For more detail see the User manual.

ACCESSORIES

Top Hat

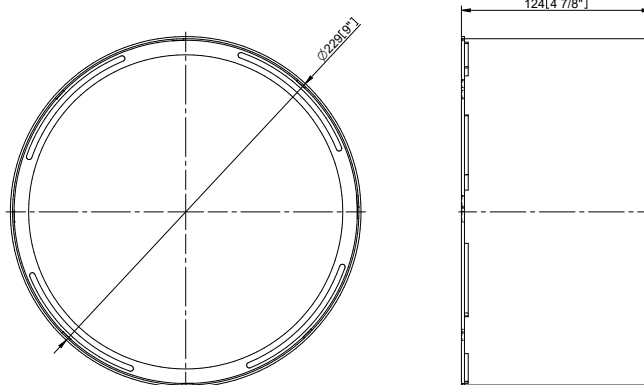

Half Top Hat

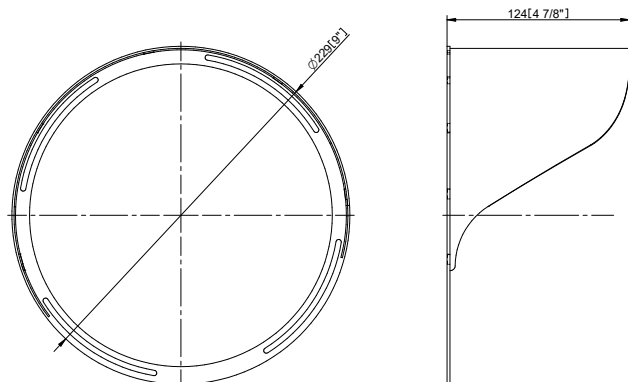

Floor Stand

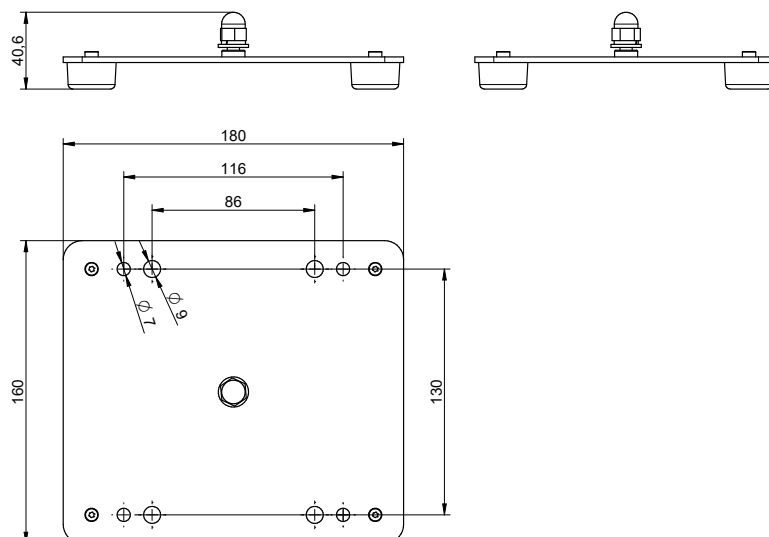

Pole Adaptor

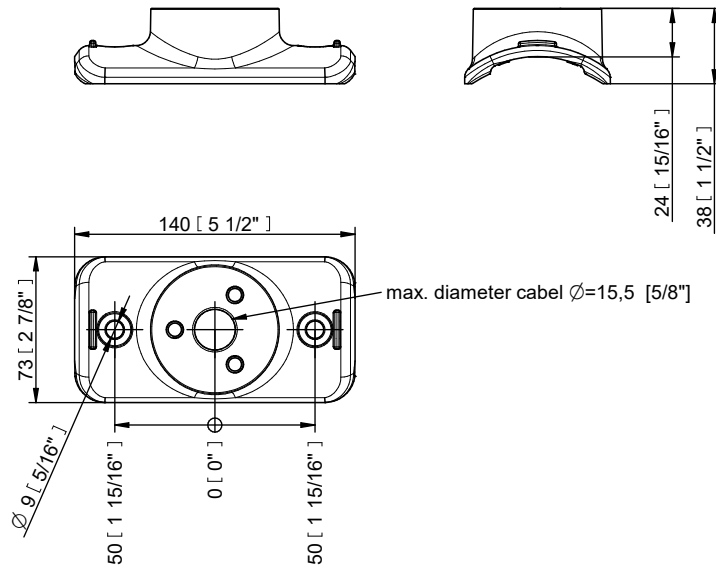

PHOTOMETRIC OVERVIEW

Lumen Output (lm)

	RGBCW (W 6500 K)	RGBA	WW (W 3000 K)
9°	2316	1986	1975
15°	1792	1537	1528
25°	1779	1526	1517
30°	1752	1502	1494
45°	1775	1522	1513
65°	1776	1523	1514
100°	1757	1507	1498
10° x 30°, 30° x 10°	1681	1442	1433
10° x 60°, 60° x 10°	1867	1601	1592
15° x 45°, 45° x 15°	1902	1631	1622
30° x 60°, 60° x 30°	1766	1514	1506
30° x 90°, 90° x 30°	1905	1634	1624
15° x 90°, 90° x 15°	2109	1809	1795

BI-SYMMETRICAL BEAM ANGLES

Bi-symmetrical:
10°x30°,
10°x60°,
15°x45°,
15°x90°,
30°x60°,
30°x90°

10°, 15°, 30°

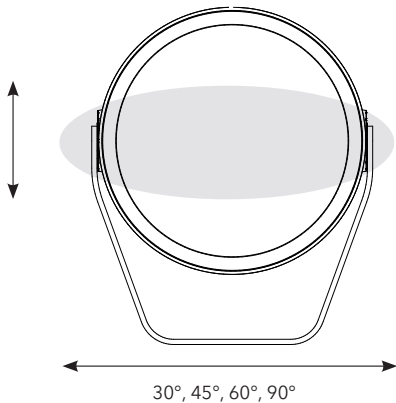

Bi-symmetrical:
30°x10°,
60°x10°,
45°x15°,
90°x15°,
60°x30°,
90°x30°

30°, 45°, 60°, 90°

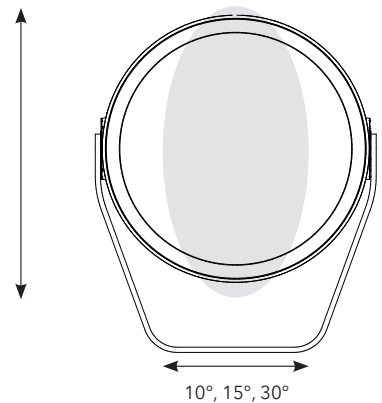

PHOTOMETRIC DATA

Calumma M MC RGBW 6500K 10dg

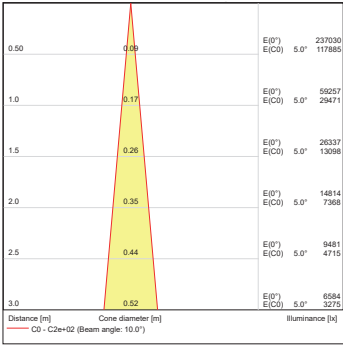
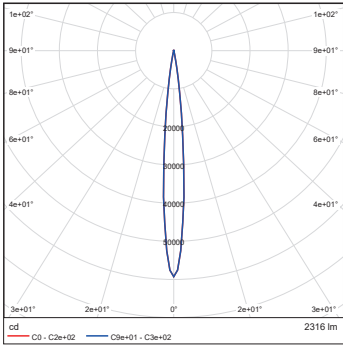

Calumma M MC RGBW 6500K 15dg

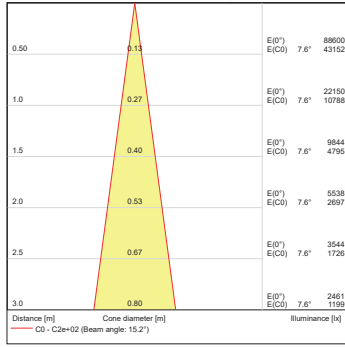
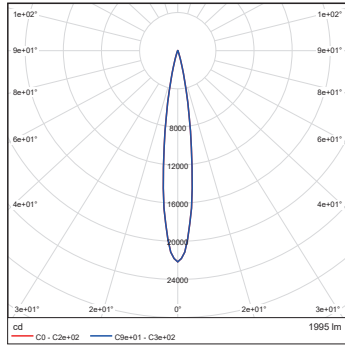

Calumma M MC RGBW 6500K 25dg

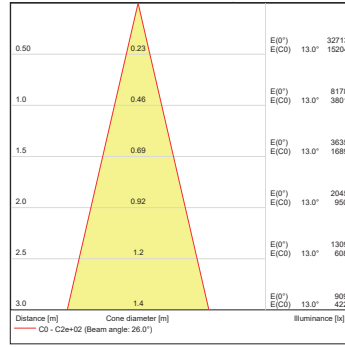
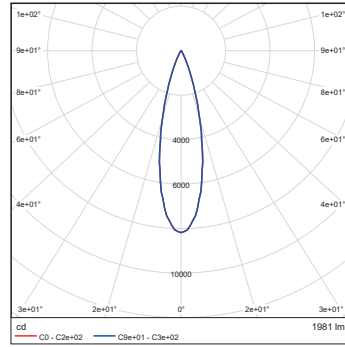

Calumma M MC RGBW 6500K 30dg

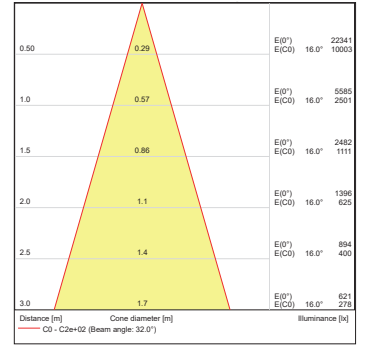
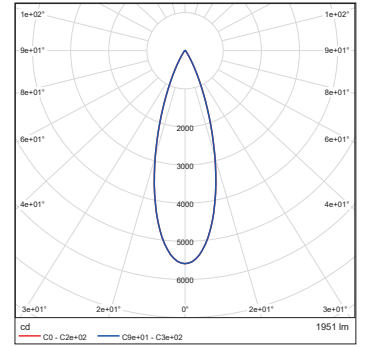

Calumma M MC RGBW 6500K 45dg

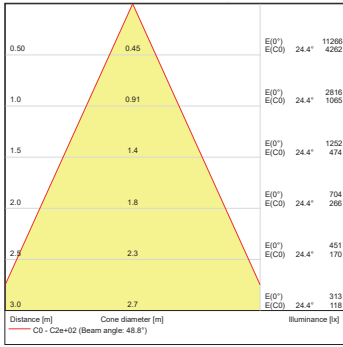
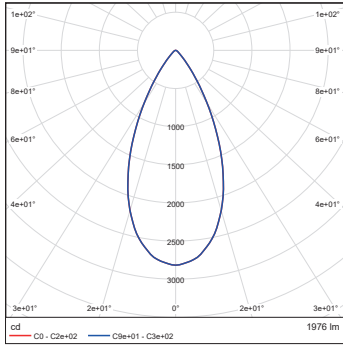

Calumma M MC RGBW 6500K 65dg

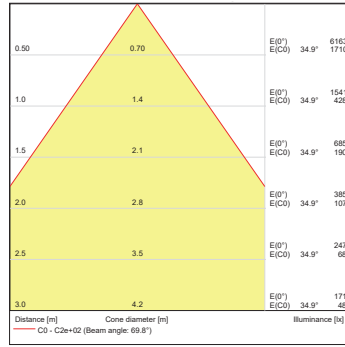
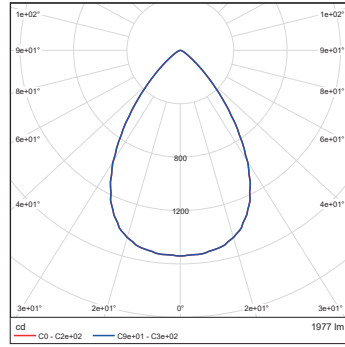

Calumma M MC RGBW 6500K 100dg

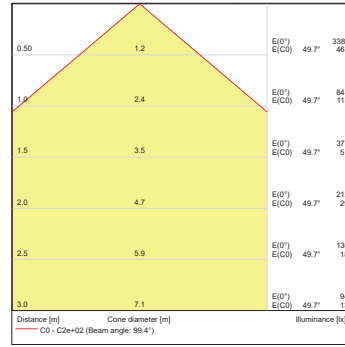
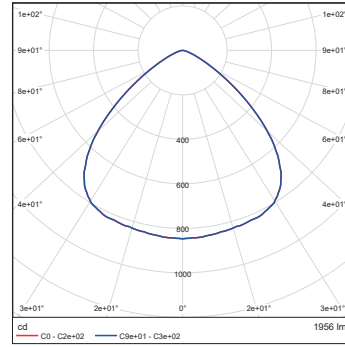

PHOTOMETRIC DATA

Calumma M MC RGBW 6500K
10x30dg

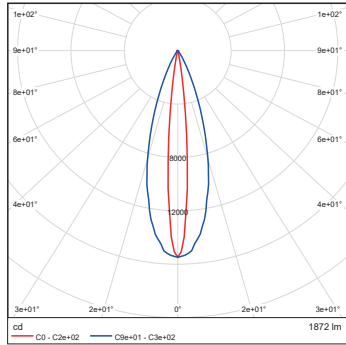

Calumma M MC RGBW 6500K
10x60dg

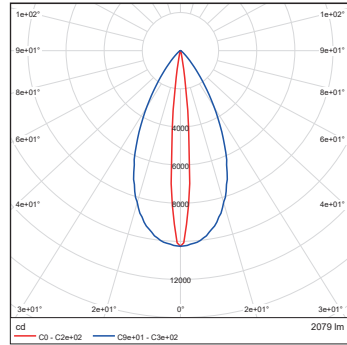

Calumma M MC RGBW 6500K
15x45dg

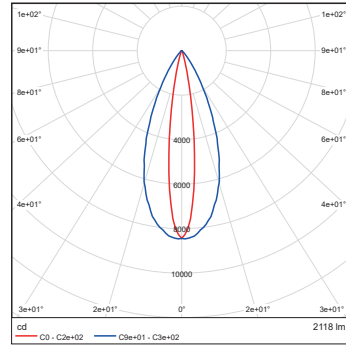

Calumma M MC RGBW 6500K
15x90dg

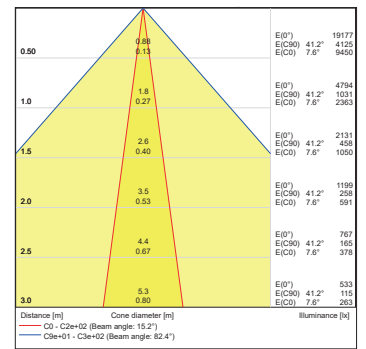
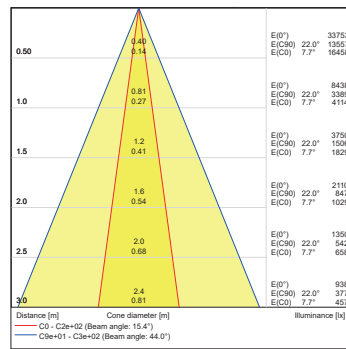
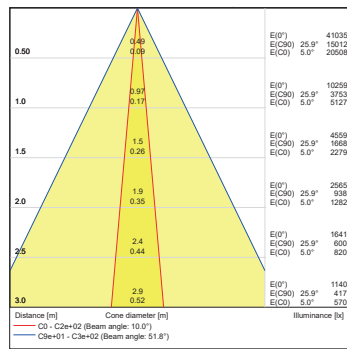
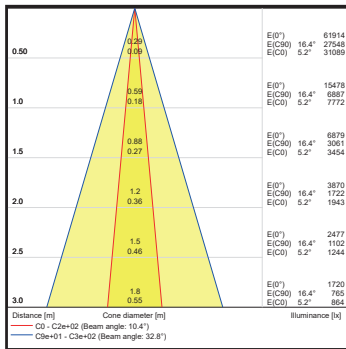
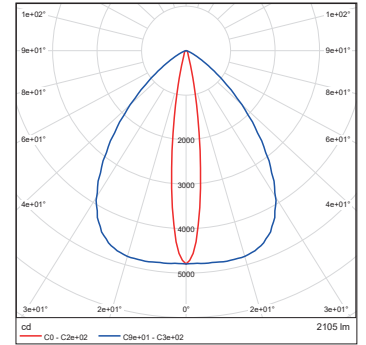

Calumma M MC RGBW 6500K
30x60dg

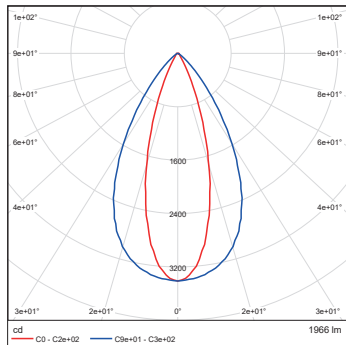

Calumma M MC RGBW 6500K
30x90dg

