

CALUMMA™ L SC

Featuring an optical design using 85 high efficacy single-chip LEDs and available with optional LED colour variants and various beam angles, the large-sized Calumma L SC luminaire creates powerful and beautiful light output for a spot, accent or flood lighting solution. Its durable housing is built to withstand any exterior conditions, and its special finish for harsh and marine environments provides an exceptional outdoor LED luminaire in an elegant design. Additionally, Calumma L SC can be connected in long In/Out daisy-chains via an E-Box and hybrid Plug & Play connections for almost effortless installation. Complemented by wide range of accessories and control protocols, this luminaire is an effective and versatile unit to get the most out of architectural lighting applications.



KEY FEATURES

Lumen output & Light source

Luminaire with 85 high-power, singlechip LEDs provides up to 7900 lumen output. Multiple LED colour variants. No light spills. Well homogenised light output with great efficacy up to 60 lm/w.

Design & Durability

Compact, durable and stylish housing made of high-pressure die cast aluminium. IP67 and IK10 certification; suitable for marine applications (Harsh Environment Finish required) and traffic applications. Supported with a 5 year warranty.

Flexibility

Exceptional outdoor or indoor LED luminaire with a wide range of accessories, custom colour finishes, multiple light output variants and beam angles.

Connectivity

Utilising the innovative E-Box series of power and data interfaces, Calumma L SC can communicate via numerous wired, wireless, and Ethernet based control protocols. Various wiring topologies are supported using hybrid power / data cables with Plug & Play connectors or standard connection options.

COLOURS

* UPON REQUEST



CONTROL & PROTOCOLS



PW & SINGLE COLOR ONLY

STANDARD & SPECIFICATION



FINISH OPTIONS

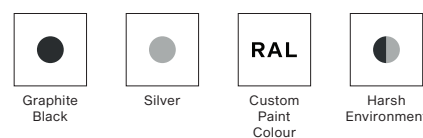

COLOUR TEMPERATURE

* UPON REQUEST

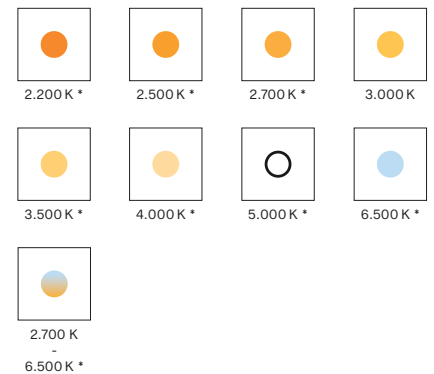

OPTIC OPTIONS

SYMMETRICAL

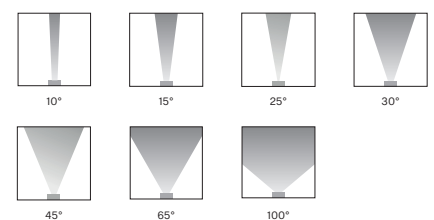

BI-SYMMETRICAL

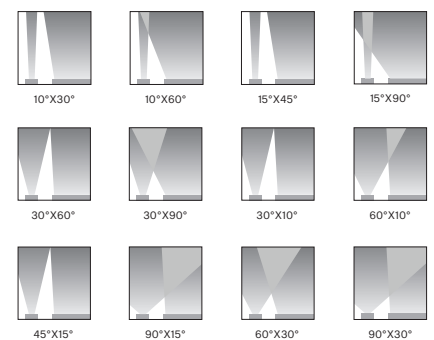

CALUMMA L SC SPECIFICATION

ELECTRICAL	Input Voltage	120 - 277 V AC 50/60 Hz (US)		
	Typical Power Consumption	130W +/-10 %		
OPTICAL	Light Source	High Power Single Chip LEDs		
	Colour Variants	RGBW (W - 6500 K) RGBA PW (W - 3000 K)		
		Other Variants On Request (TW (2700 - 6500 K), 2200 K, 2500 K, 2700 K, 3500 K, 4000 K, 5000 K, 6500 K)		
	Beam Angle	10° 15° 25° 30° 45° 65° 100°		
		10°x30° 30°x10° 10°x60° 60°x10° 15°x45° 45°x 15° 15°x90° 90°x15° 30°x60° 60°x30° 30°x90° 90°x30°		
	Lumen Output Delivered	7900 lm (@ 10°, RGBW)		
	Projected Lumen Maintenance	L90B10 >90.000 hrs, Ta = 25°C / 77°F		
CONTROL	Interface Protocol	Via E-box range, DMX/RDM, wireless DMX, DALI 2 or ON/OFF (PW & single color only)		
	E-box control protocol	USITT DMX512+RDM, ArtNet, MA Net, MA Net2, sACN, Kling-Net		
	DALI 2 Device Type	DT 8		
	Wireless DMX (Option)	Lumen Radio CRMX Technology		
	Control System	Third Party DMX Controllers or third party DALI 2 controllers, Ethernet		
	Operating Modes	DMX, Stand-alone		
	Settings / Addressing	E-Box, RDM communicator		
	Power Supply	Integrated		
		Width x Height x Depth	338 x 360 x 116 mm (13.31 x 14.13 x 4.57 in.)	
		Weight	9.7 kg 21.38 lbs	
PHYSICAL	Housing	High Pressure Die-Cast Aluminium Body Tempered Glass		
	Finish Options	Standard Colour - Graphite Black (RAL 9011) Silver (RAL 9006) Cost Option - Custom RAL Harsh Environment (RAL 9016, RAL 9011)		
	Cables / Connections	IN/OUT (for E- Box version): - 0,5 m cables with hybrid connectors - Jumper cables	IN (for DMX, DALI, ON / OFF): - 1 m cable with bare-end - Other cable length - custom - Junction box - optional	
	Mounting Method	Yoke or Yoke for Pole Adaptor		
	Adjustability	+180° / -180°		
	Protection Factor	IP67 / Suitable For Wet Locations		
	IK Rating	IK10		
	Cooling System	Convection		
	Operating Ambient Temperature	-20 °C / +50 °C (-4 °F / +122 °F)		
CERTIFICATION	Listings	ETL / cETL, CE, RoHS, UKCA		
ACCESSORIES	Not Included Items			
		Junction Box for Calumma		
		Optical Demo Set for Calumma L (for demo purposes)		
		Outdoor Foil Holder for Calumma L (for permanent installation)		
		Optical Foil Set for Outdoor Foil Holder Calumma L		
		Land Spike for Calumma L		
		Top Hat Calumma L		
		Half Top Hat Calumma L		
		Tenon Adaptor for Calumma L		
		Floor stand for Calumma L, XL		
		Pole Adaptor (ø 102mm) (Yoke for Pole Adaptor Required)		

PROJECTED AREA

	Front (rear) - m ²	Front (rear) ft ²	Side - m ²	Side - ft ²	Top - m ²	Top - ft ²
Calumma L	0,080	0,861	0,037	0,398	0,035	0,373
with Top Hat	0,080	0,861	0,087	0,936	0,085	0,911
with Half Top Hat	0,080	0,861	0,059	0,635	0,082	0,882

DIMENSIONS

Standard Yoke

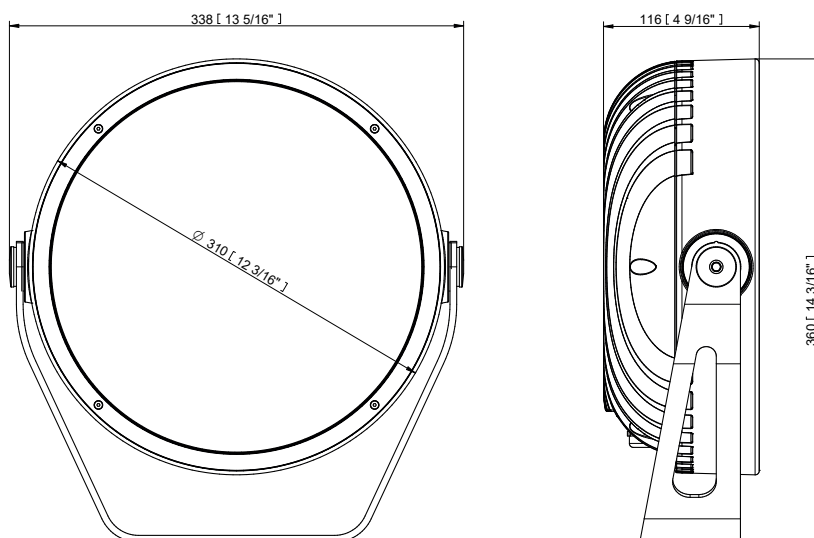

Yoke for Pole Adaptor (with Pole Adaptor / PA)

Example of ordering code: Calumma L SC RGCW 15° PA

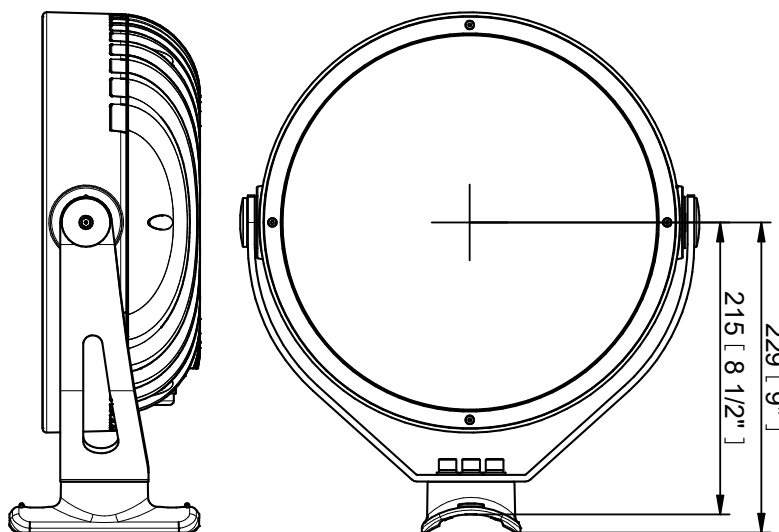

CONTROL AND CONNECTION OPTIONS - CE

DALI

- 1) Hybrid Cable (1305 3693)
Standard 1 m with bare-end
- 2) Hybrid Cable (1305 3693)
or
Scope of Others
- 3) Junction Box for Calumma

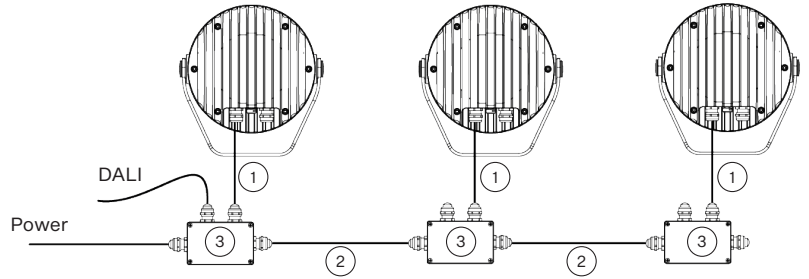

DMX

- 1) Flamar 3x AWG 16 + 1 x (2x AWG 24)
Standard 1 m with bare-end, (13051508), black
or
Hybrid Cable HYB-5731ZH LSZH (13053694), white
- 2) Flamar 3x AWG 16 + 1 x (2x AWG 24), (13051508), black
or
Hybrid Cable HYB-5731ZH LSZH (13053694) white
or
Scope of Others
- 3) Junction Box for Calumma

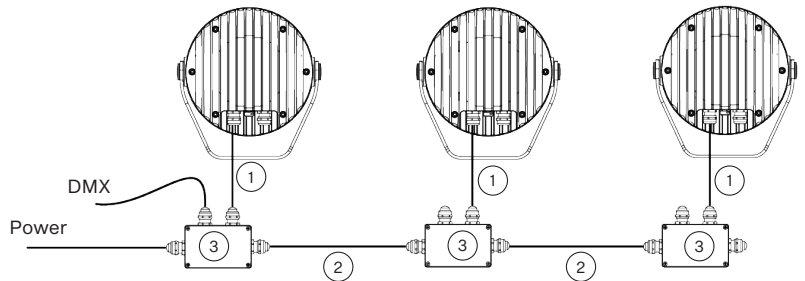

WIRELESS DMX

- 1) Flamar 3x AWG 16 + 1x (2x AWG 24),
(13051508), Standard 1 m bare-end, black
or
Hybrid Cable HYB-5731ZH LSZH (13053694), white
- 2) Junction Box for Calumma

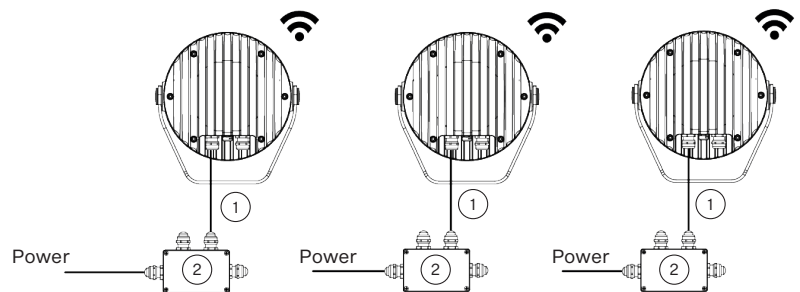

Note: This type of connection is available for M, L, XL versions.

- 1) Flamar 3x AWG 16 + 1x (2x AWG 24)
(13051508), Standard 1 m bare-end, black
or
Hybrid Cable HYB-5731ZH LSZH (13053694), white
- 2) Junction Box for Calumma
- 3) Flamar 3x AWG 16 + 1 x (2x AWG 24), (13051508)
or
Hybrid Cable HYB-5731ZH LSZH (13053694), white
or
Scope of Others

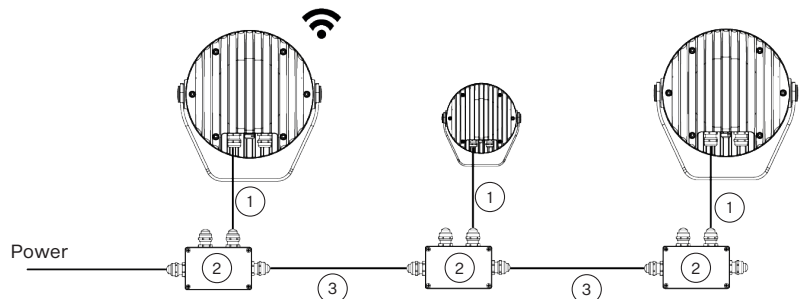

Note: This type of connection must have M, L or XL versions as the first luminaire. Next luminaires in a row could be chosen from S, M, L or XL versions.

CONTROL AND CONNECTION OPTIONS - CE

DMX or ETHERNET via E-BOX

- 1) Flamar 3x AWG 16 + 1x (2x AWG 24) (13051508), Standard 1 m with bare-end, black or Hybrid Cable HYB-5731ZH LSZH (13053694), white
- 2) Junction Box for Calumma
- 3) Flamar 3x AWG 16 + 1x (2x AWG 24), (13051508), black or Hybrid Cable HYB-5731ZH LSZH (13053694) white or Scope of Others

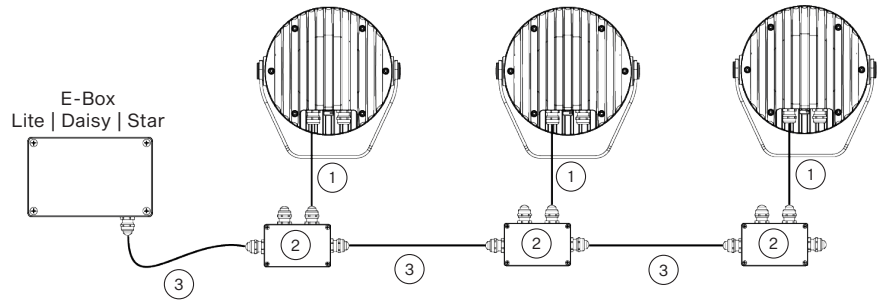

Note: This type of connection is available for S, M, L, and XL versions. E-Box has to be in Pass Through mode only.

- 1) Leader Cable MM (13053493) Standard 0,5 m with hybrid connector
- 2) Leader Cable MF (13053494) Standard 0,5 m with hybrid connector
- 3) Leader Cable FF 2 m (13053438)
Leader Cable FF 5 m (13053440)
Leader Cable FF 10 m (13053436)
Leader Cable FF 25 m (13053437)
Leader Cable FF 50 m (13053439)

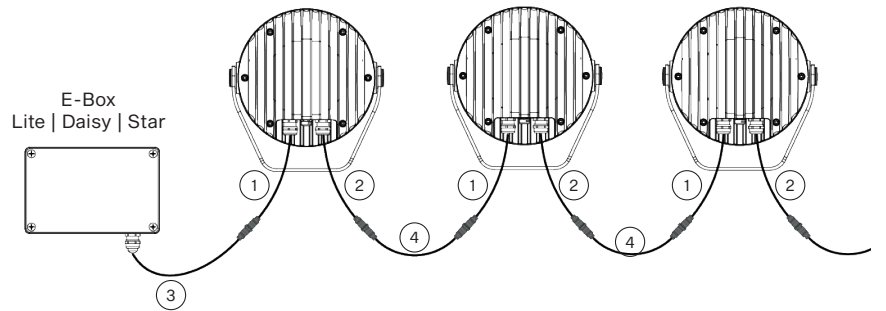

- 4) Jumper Cable FF/FM 0,25 m (13053422)
Jumper Cable FF/FM 0,5 m (13053423)
Jumper Cable FF/FM 1 m (13053425)
Jumper Cable FF/FM 2 m (13053427)
Jumper Cable FF/FM 3 m (13053428)
Jumper Cable FF/FM 5 m (13053430)
Jumper Cable FF/FM 10 m (13053424)

Note: With this type of connection is possible to connect Calumma (M, L, XL) and Eminere (Eminere, Eminere Side) luminaires in a row.

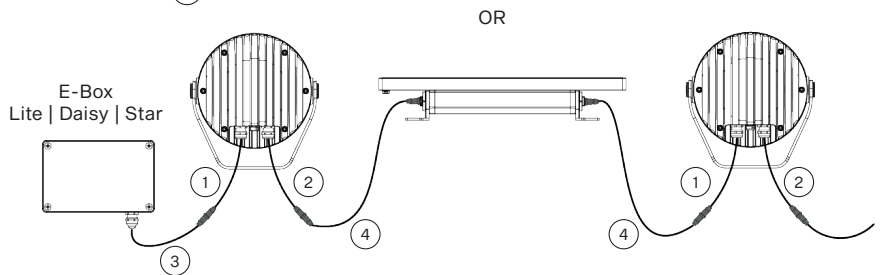

ON/OFF

- 1) 3-cored cable H07BB-F 3G 1.5 (1305 1443), Standard 1 m with bare-end

Note: This type of connection is available for Pure White and single color version only. Non dimmable.

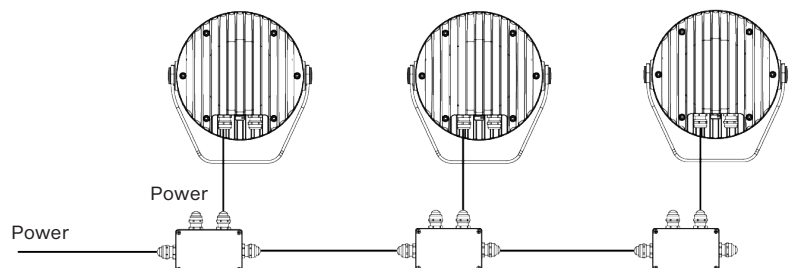

CONTROL AND CONNECTION OPTIONS - US

DALI

- 1) SJTW 5x 14AWG (13053336), Standard 1 m with bare-end, black
or
Cable SJTW 5x 14AWG (13053697), white
- 2) SJTW 5x 14AWG (13053336), black
or
Cable SJTW 5x 14AWG (13053697), white
or
Scope of Others
- 3) Junction Box for Calumma

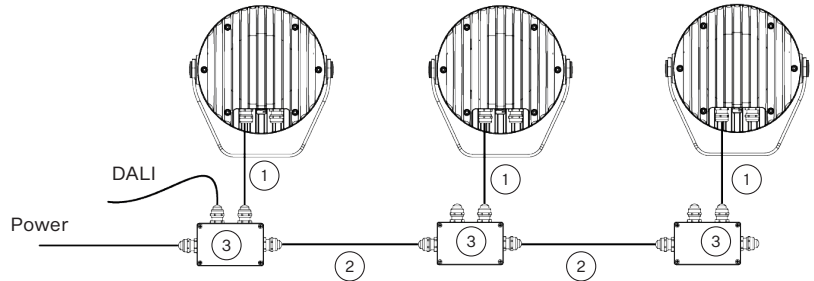

WIRELESS DMX

- 1) SJTW 6x 14AWG (13053480), Standard 1 m with bare-end, black
or
Cable SJTW 6x 14AWG (13053695), white
- 2) Junction Box for Calumma

Note: This type of connection is available for M, L, XL versions

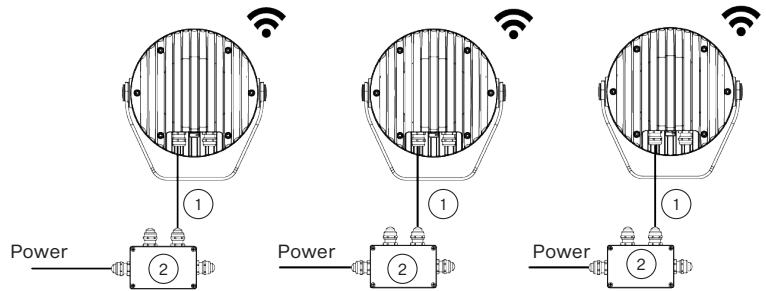

- 1) SJTW 6x 14AWG (13053480), Standard 1 m with bare-end, black
or
Cable SJTW 6x 14AWG (13053695), white
- 2) Junction Box for Calumma
- 3) SJTW 6x 14AWG (13053480), black
or
Cable SJTW 6x 14AWG (13053695), white
or
Scope of Others

Note: This type of connection must have M, L or XL versions as the first luminaire. Next luminaires in a row could be chosen from S, M, L or XL versions.

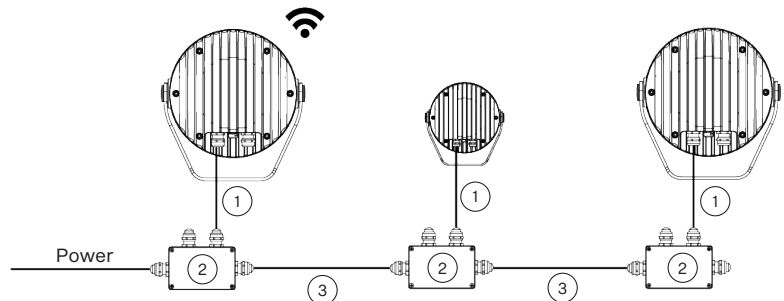

CONTROL AND CONNECTION OPTIONS - US

DMX or ETHERNET via E-BOX

- 1) SJTW 6x 14AWG (13053480)
Standard 1 m with bare-end, black
or
Cable SJTW 6x 14AWG (13053695), white
- 2) Junction Box for Calumma
- 3) SJTW 6x 14AWG (13053480), black
or
Cable SJTW 6x 14AWG (13053695), white
or
Scope of Others

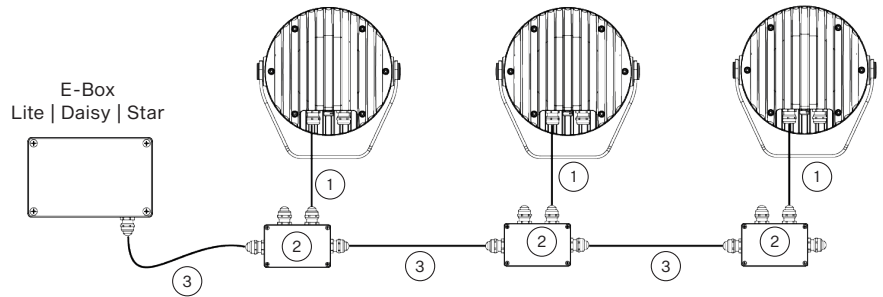

Note: This type of connection is available for S, M, L, and XL versions. E-Box has to be in Pass Through mode only.

ON/OFF

- 1) 3-cored cable SEOOW power 3x16 AWG (13051558-01), Standard 1 m with bare-end

Note: This type of connection is available for Pure White & single color version only. Non dimmable.

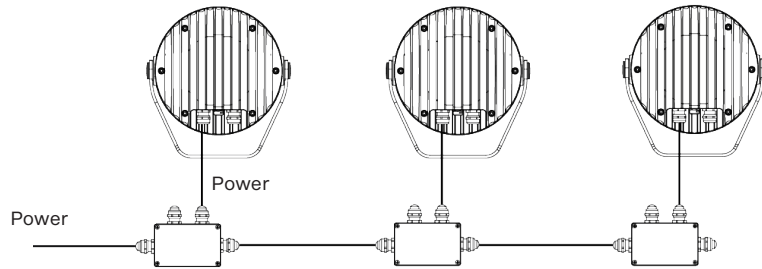

CONNECTIVITY

Following table shows maximum connected Calummas L SC in a row with respect of cable length.

STANDARD MODE	Cable length (m)	Voltage (V)			
		120	190	230	277
CALUMMA L SC	10	17	26	32	38
	20	17	26	32	38
	30	12	26	32	38
	50	7	18	26	37
	70	5	13	18	27
	100	3	9	13	19
	200	3	4	6	9
	500	1	2	3	4

PASS-THROUGH MODE	Cable length (m)	Voltage (V)			
		120	190	230	277
CALUMMA L SC	10	17	26	32	32
	20	17	26	32	32
	30	12	26	32	32
	50	7	18	26	32
	70	5	13	18	27
	100	3	9	13	19

BOOSTER BOX POSITIONS

	Cable length (m)	Max. number of Calummas L MC= 191 (in Standard mode)			
		120 V	190 V	230 V	277 V
CALUMMA L SC	10 m	14, 28	22	27	-
	20 m	14, 28, 42, 54	22, 44	27, 54	32
	30 m	10, 20, 30, 40, 50, 60, 70, 80	22,44,66	27,54,81	32,64
	50 m	6, 12, 18, 24, 30, 36, 42, 48, 54, 60, 66, 72, 78, 84, 90, 96, 102....	15, 30, 45, 60, 75, 90, 105, 120, 135..	22, 44, 66, 88, 110, 132...	32, 64, 96, 128...
	70 m	4, 8, 12, 16, 20, 24, 28, 32, 36, 40, 44, 48, 52, 56, 60, 64, 68, 72, 76, 80, 84....	11, 22, 33, 44, 55, 66, 77, 88, 99, 110...	16, 32, 48, 64, 80, 96, 112, 128, 144...	23, 46, 69, 92, 115, 138, 161, ...
	100 m	3, 6, 9, 12, 15, 18, 21, 24, 27, 30, 33, 36, 39, 42, 45, 48, 51, 54, 57, 60, 63, 66, 69, 72, 75, 78, 81...	7, 14, 21, 28, 35, 42, 49, 56, 63, 70, 77, 84, 91, 98, 105...	11, 22, 33, 44, 55, 66, 77, 88, 99, 110, 121, 132...	16, 32, 48, 64, 80, 96, 112, 128, 144, 160
	200 m	1, 2, 3, 4, 5, 6, 7, 8, 9, 10, 11....	4, 8, 12, 16, 20, 24, 28, 32, 36, 40, 44, 48, 52, 56, 60, 64, 68, 72, 76, 80, 84...	5, 10, 15, 20, 25, 30, 35, 40, 45, 50, 55, 60, 65, 70, 75...	8, 16, 24, 32, 40, 48, 56, 64, 72, 80, 88, 96...
	500 m	1, 2, 3, 4, 5, 6, 7, 8, 9, 10, 11....	1, 2, 3, 4, 5, 6, 7, 8, 9, 10, 11....	2, 4, 6, 8, 10, 12, 14, 16, 18, 20...	3, 6, 9, 12, 15, 18, 21....

NOTE: For more detail see the User manual.

ACCESSORIES

Top Hat

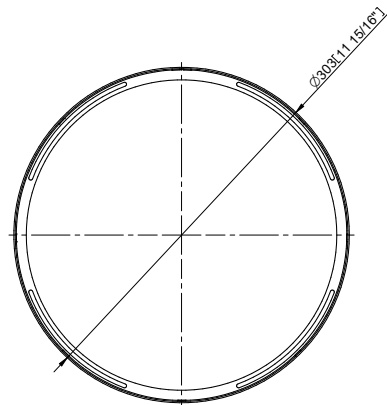

Half Top Hat

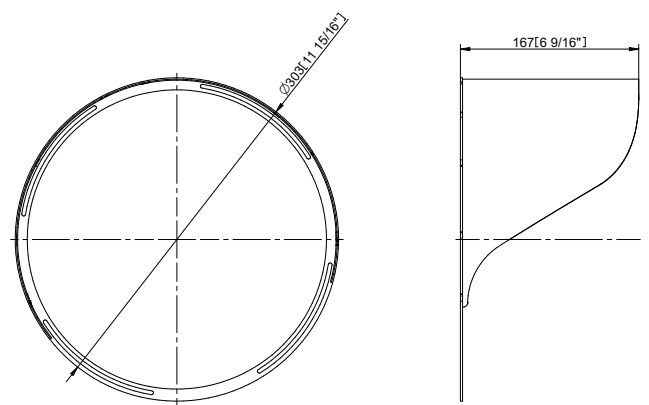

Floor Stand

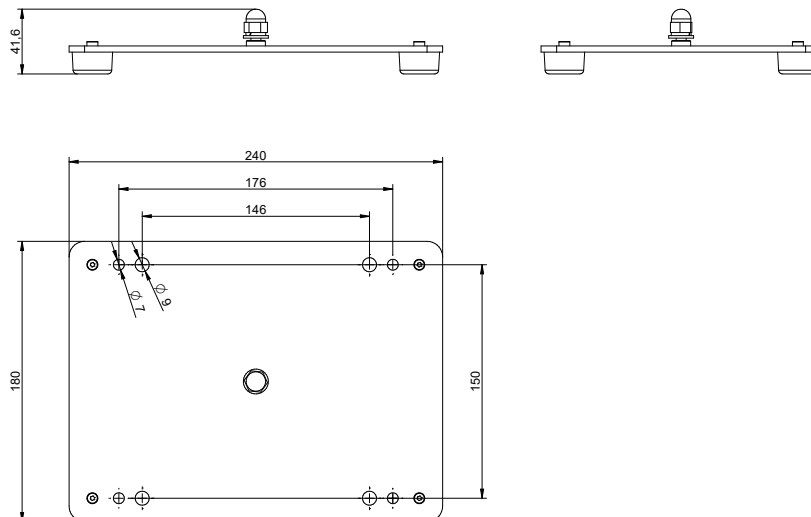

Pole Adaptor

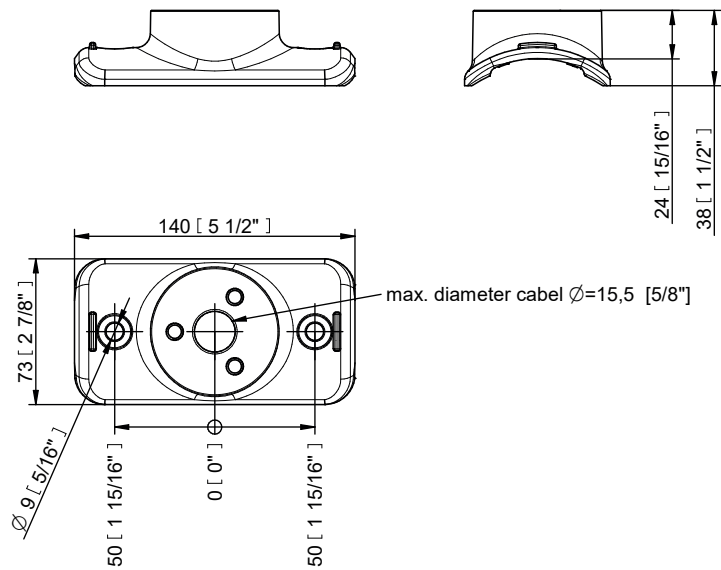

PHOTOMETRIC OVERVIEW

Lumen Output (lm)

	RGBCW (W 6500 K)	RGBA	WW (W 3000 K)
10°	7900	5539	9779
15°	7198	5047	8910
25°	7035	4933	8708
30°	6905	4842	8548
45°	7051	4944	8728
65°	6912	4847	8556
100°	6998	4907	8663
10° x 30°, 30° x 10°	6951	4874	8604
10° x 60°, 60° x 10°	6917	4850	8562
15° x 45°, 45° x 15°	7216	5060	8933
30° x 60°, 60° x 30°	6876	4821	8512
30° x 90°, 90° x 30°	6481	4544	8023
15° x 90°, 90° x 15°	6805	4772	8424

BI-SYMMETRICAL BEAM ANGLES

Bi-symmetrical:

10°x30°,
10°x60°,
15°x45°,
15°x90°,
30°x60°,
30°x90°

10°, 15°, 30°

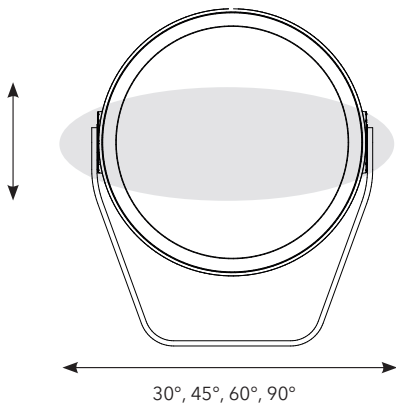

Bi-symmetrical:

30°x10°,
60°x10°,
45°x15°,
90°x15°,
60°x30°,
90°x30°

30°, 45°, 60°, 90°

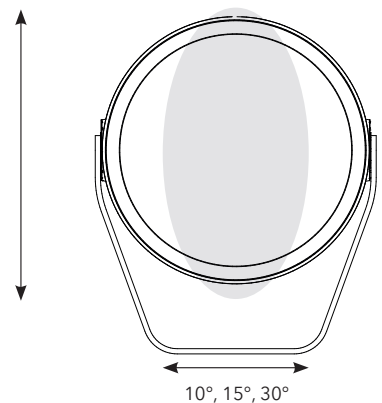

PHOTOMETRIC DATA

Calumma L SC RGBW 6500K 10dg

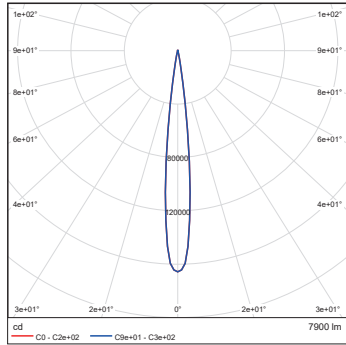

Distance [m]	Cone diameter [m]	E(0°) E(C0)	E(0°) E(C0)
0.50	0.11	662703	327210
1.0	0.21	168676	81802
1.5	0.32	73834	36357
2.0	0.42	41419	20451
2.5	0.53	28508	13088
3.0	0.63	18498	8959

Calumma L SC RGBW 6500K 15dg

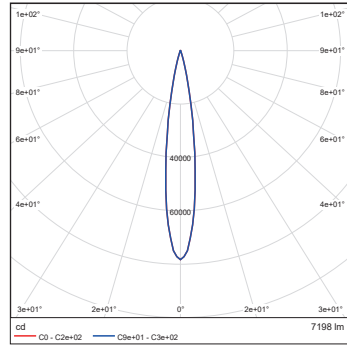

Distance [m]	Cone diameter [m]	E(0°) E(C0)	E(0°) E(C0)
0.50	0.14	313093	152941
1.0	0.28	78273	38235
1.5	0.42	34788	16993
2.0	0.56	19688	9559
2.5	0.69	12504	6118
3.0	0.83	8097	4048

Calumma L SC RGBW 6500K 25dg

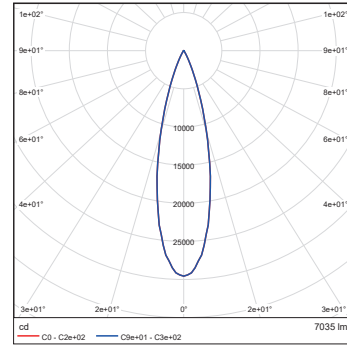

Distance [m]	Cone diameter [m]	E(0°) E(C0)	E(0°) E(C0)
0.50	0.23	118241	56884
1.0	0.47	29560	13671
1.5	0.70	13138	6076
2.0	0.94	7390	3418
2.5	1.2	4730	2187
3.0	1.4	3284	1518

Calumma L SC RGBW 6500K 30dg

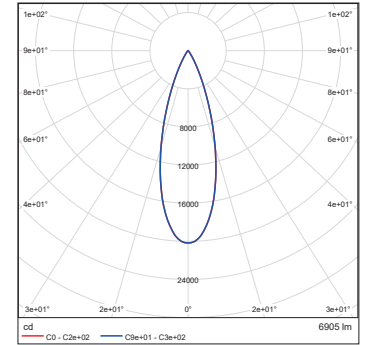

Distance [m]	Cone diameter [m]	E(0°) E(C0)	E(0°) E(C0)
0.50	0.29	86886	38959
1.0	0.58	20172	8965
1.5	0.87	8965	3984
2.0	1.2	5043	2241
2.5	1.4	3227	1434
3.0	1.7	2241	956

Calumma L SC RGBW 6500K 45dg

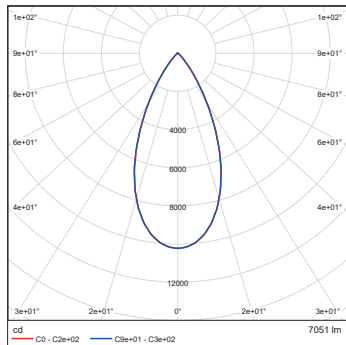

Distance [m]	Cone diameter [m]	E(0°) E(C0)	E(0°) E(C0)
0.50	0.45	40890	18517
1.0	0.90	10234	3879
1.5	1.4	4844	1754
2.0	1.8	2556	970
2.5	2.3	1638	621
3.0	2.7	1136	431

Calumma L SC RGBW 6500K 65dg

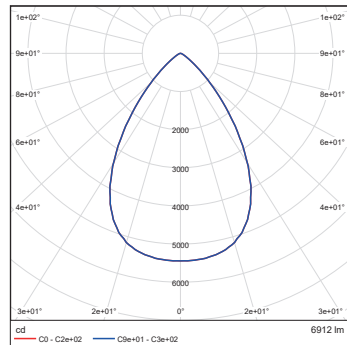

Distance [m]	Cone diameter [m]	E(0°) E(C0)	E(0°) E(C0)
0.50	0.70	21767	6033
1.0	1.4	5442	1508
1.5	2.1	2619	670
2.0	2.8	1360	377
2.5	3.5	871	241
3.0	4.2	605	168

Calumma L SC RGBW 6500K 100dg

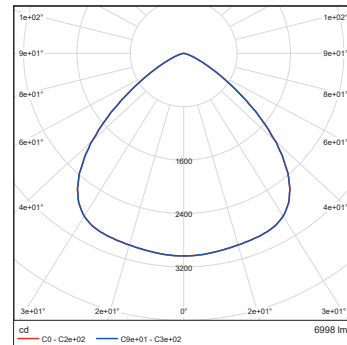

Distance [m]	Cone diameter [m]	E(0°) E(C0)	E(0°) E(C0)
0.50	1.2	12140	1646
1.0	2.4	3035	412
1.5	3.5	1369	183
2.0	4.7	759	103
2.5	5.9	486	66
3.0	7.1	337	46

PHOTOMETRIC DATA

Calumma L SC RGBW 6500K 10x30dg

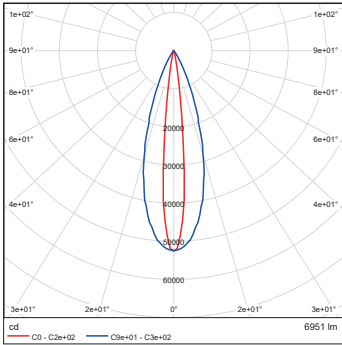

Calumma L SC RGBW 6500K 10x60dg

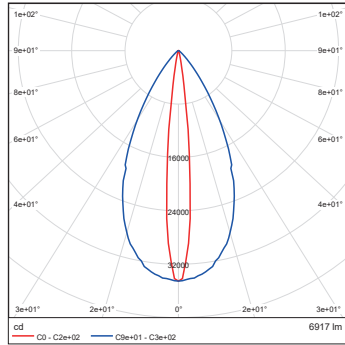

Calumma L SC RGBW 6500K 15x45dg

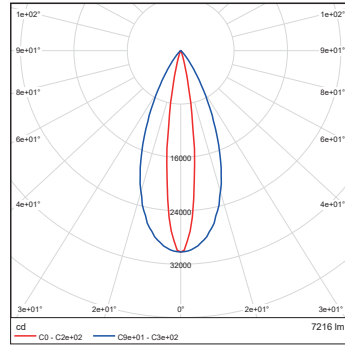

Calumma L SC RGBW 6500K 15x90dg

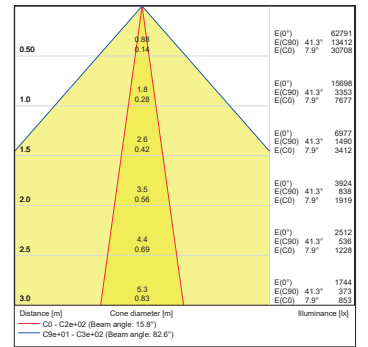
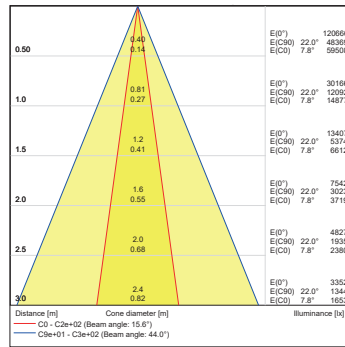
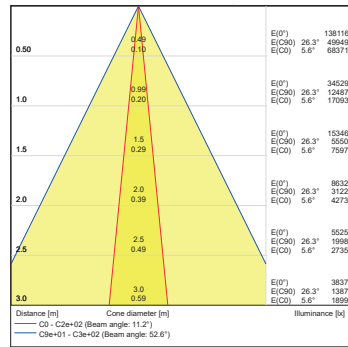
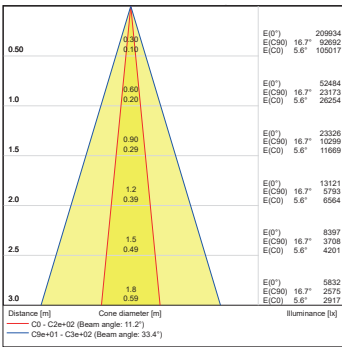
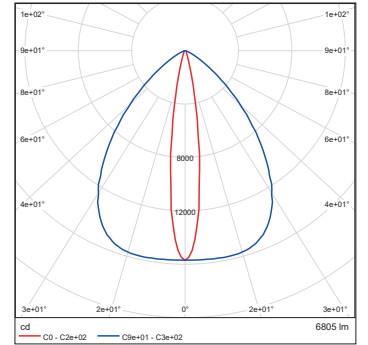

Calumma L SC RGBW 6500K 30x60dg

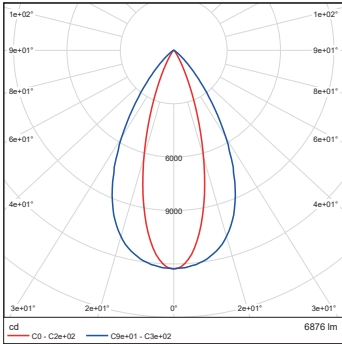

Calumma L SC RGBW 6500K 30x90dg

