

Eminere 2 Wireless DMX
Eminere 3 Wireless DMX
Eminere 4 Wireless DMX

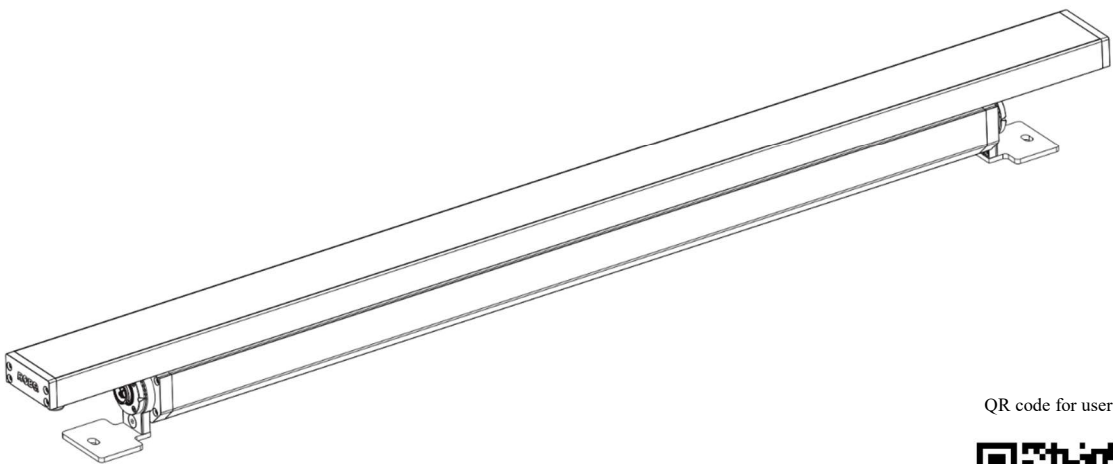

QR code for user manual



USER MANUAL

Version 1.9

Table of contents

1. Safety instructions	3
2. Fixture exterior view	4
3. Installation	5
3.1 Mounting the fixture	5
3.2 Connection to mains	5
3.3 The Booster box	7
3.4 The Booster box installation	9
3.5 Jumper cable assembling	11
4. Technical specifications	14
5. Cleaning and maintenance	17
5.1 Disposing of the product	17
6. ChangeLog	17

**FOR YOUR OWN SAFETY, PLEASE READ THIS USER MANUAL CAREFULLY
BEFORE POWERING OR INSTALLING YOUR Eminere !
Save it for future reference.**

This device has left our premises in absolutely perfect condition. In order to maintain this condition and to ensure safe operation, it is absolutely necessary for the user to follow the safety instructions and warnings written in this manual.

The manufacturer will not accept liability for any resulting damages caused by the non-observance of this manual or any unauthorized modification to the device.

Unauthorized modification will void warranty.

1. Safety instructions

DANGEROUS VOLTAGE CONSTITUTING A RISK OF ELECTRIC SHOCK IS PRESENT WITHIN THIS UNIT!

This fixture should be operated only from the type of power source indicated on the marking label. If you are not sure of the type of power supplied, consult your authorized distributor or local power company.

Always disconnect the fixture from AC power before cleaning, servicing or installing.

Make sure the data/power cable is not damaged by sharp edges. Check the fixture and the power cord from time to time.

Do not install the unit near an open flame.

During operation the housing becomes hot.

Refer servicing to qualified service personnel.

This fixture falls under protection class I. Therefore this fixture has to be connected to a mains socket outlet with a protective earthing connection.

Do not connect this fixture to a dimmer pack.

LED light emission. Risk of eye injury. Do not look into the beam from a short distance without suitable protective eyewear. Do not look at LEDs with magnifiers or similar optical instruments that may concentrate the light output.

The fixture was designed for outdoor use. This fixture must not be used for underwater installation.

When choosing the installation spot, please make sure that the fixture is not exposed to extreme heat or dust.

Avoid using the unit in locations subject to possible impacts.

The fixture body never must be covered with cloth or other materials when the fixture is under operation.

Only operate the fixture after having checked that the housing is firmly closed and all screws are tightly fastened.

Eminere Wireless DMX

The fixture becomes hot during operation. Allow the fixture to cool approximately 30 minutes prior to servicing or maintenance.

Operate the fixture only after having familiarized yourself with its functions. Do not permit operation by persons not qualified to operate the fixture. Most damages are the result of unprofessional operation!

Immunity of the equipment is designed for electromagnetic environments E1, E2, E3 according to the standard EN55103-2 ed.2 Electromagnetic compatibility. Product family standard for audio, video, audiovisual and entertainment lighting control apparatus for professional use. Part 2: Immunity.
The product (covers and cables) must not be exposed to a high frequency electromagnetic field higher than 3V/m.

The installation company should check levels of possible interferences above the tested levels E1,E2,E3 given by this standard (e.g. transmitters in surrounding area) before installing the equipment.
Emission of the equipment complies with the standard EN55032 Electromagnetic compatibility of multimedia equipment – Emission Requirements according to class B.

Please consider that unauthorized modifications on the fixture are forbidden due to safety reasons!

Please use the original packaging if the fixture is to be transported.

If this device will be operated in any way different to the one described in this manual, the product may suffer damages and the warranty becomes void. Furthermore, any other operation may lead to dangers like short-circuit, burns, electric shock etc.

2. Fixture exterior view

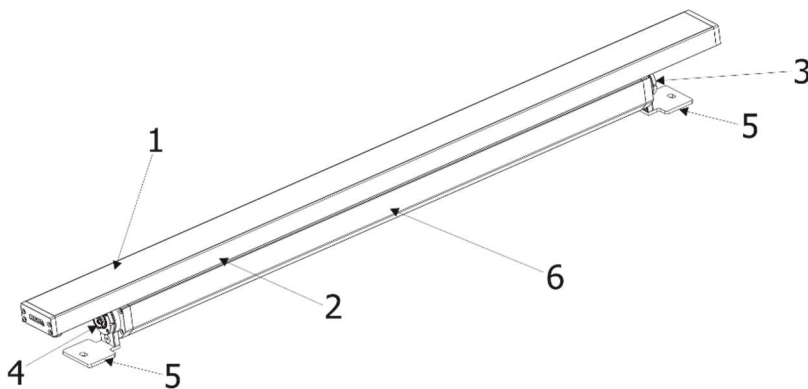

1. Transparent glass cover
2. LED module
3. Output connector
4. Input connector
5. Mounting brackets
6. Aluminium base

3. Installation

3.1 Mounting the fixture

The Eminere can be arranged in any orientation on a flat, non-flammable surface by means of two mounting brackets (5), the LED module (2) can be tilted (+95°/-95°) to get access to mounting brackets (5).

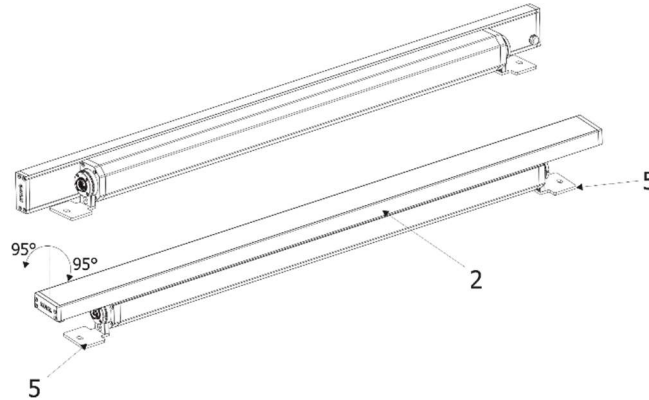

Ensure that the structure to which you are attaching the unit is secure.

3.2 Connection to mains

**The unit must be installed by a qualified electrician in accordance with all national and local electrical and construction codes and regulations.
This device falls under class one and must be grounded!**

The Eminere is equipped with auto-switching power supply that automatically adjusts to any 50/60Hz AC power source from 120-277 Volts.

The following wiring of the input/output connectors applies to the fixtures marked **X** on their labels only. Older versions of the Emineres have swapped D- and D+ and do not have mark **X** on their labels.



Input - panel connector
(front view)

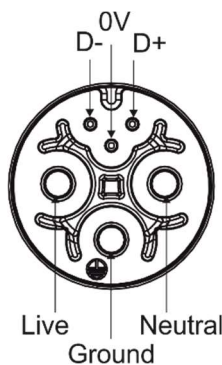

Output - panel connector
(front view)

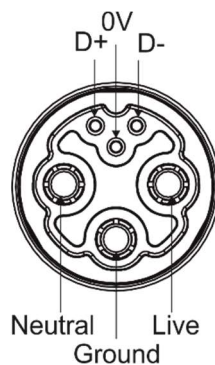

Fixture's Amphenol connectors are dust and water protected according to IP 67 by mating with related Amphenol connectors.

They cannot stay disconnected outdoor.

The output panel connector at last fixture in the Emineres chain has to always be covered with the water-tight cap to keep declared IP rating.

Do not connect (disconnect) Emineres to the Booster box and each other when they are under voltage!

Direct visibility between a transmitter and the Eminere Wireless DMX must be ensured without no obstacles (buildings, trees,...).

Distance between a DMX transmitter and the Eminere Wireless DMX depends on transmission range of used DMX transmitter, surrounds etc (we recommend to test behaviour of DMX transmitter with the Eminere Wireless DMX before installation).

Examples of connection

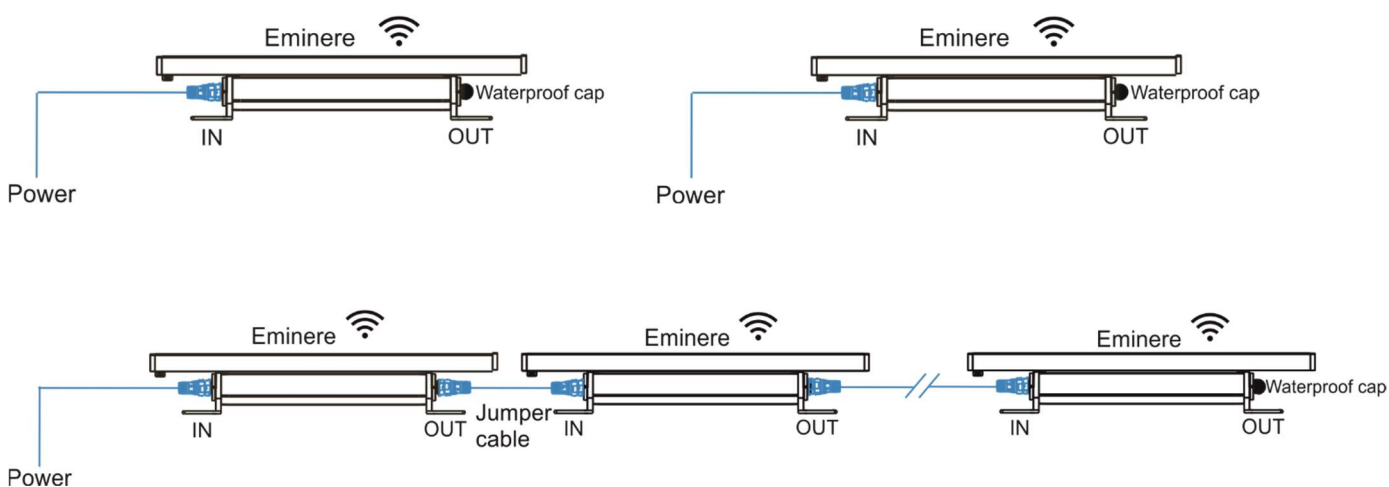

The Eminere can be only linked to a transmitter by running the link procedure at DMX transmitter . The Eminere can be unlinked from the transmitter by running the unlink procedure at DMX transmitter or by switching off/on the Eminere three times while the transmitter is switched off.

During off/on unlink procedure, the Eminere has to be switched on for 5 seconds in steps 1-3:

- Step 1: Eminere Off, Eminere On (5seconds)
- Step 2: Eminere Off, Eminere On (5seconds)
- Step 3: Eminere Off, Eminere On (5seconds)
- Step 4: Eminere Off, Eminere On

Successful unlink is signaled by flashing LEDs at fourth switching the Eminere Off and On. If the LEDs flashing will not appear, probably the 5 seconds period has not been kept and you have to repeat the Off/On procedure to unlink the fixture from the DMX transmitter .

DMX addressing of connected Emineres has to be done manually by means of the Robe Universal Interface WTX and the software RDM Manager.

The tables below state max. theoretical number of Emineres connected in series without Booster boxes.

EMINERE 2 wireless DMX	Voltage			
	120V	190V	230V	277V
Cable length *				
10 m	32	32	32	32
20 m	32	32	32	32
30 m	28	32	32	32

Eminere Wireless DMX

50 m	17	32	32	32
70 m	12	31	32	32
100 m	9	21	32	32

EMINERE 3 wireless DMX	Voltage			
	120V	190V	230V	277V
Cable length *				
10 m	28	32	32	32
20 m	28	32	32	32
30 m	19	32	32	32
50 m	12	29	32	32
70 m	8	21	31	32
100 m	6	15	21	31

EMINERE 4 wireless DMX	Voltage			
	120V	190V	230V	277V
Cable length *				
10 m	21	32	32	32
20 m	21	32	32	32
30 m	15	32	32	32
50 m	9	22	32	32
70 m	6	16	23	32
100 m	4	11	16	23

* Cable length is a total cable length among connected Emineres Side including power cable of the first Eminere Side.

Example: Total cable length=L1+L2+L3

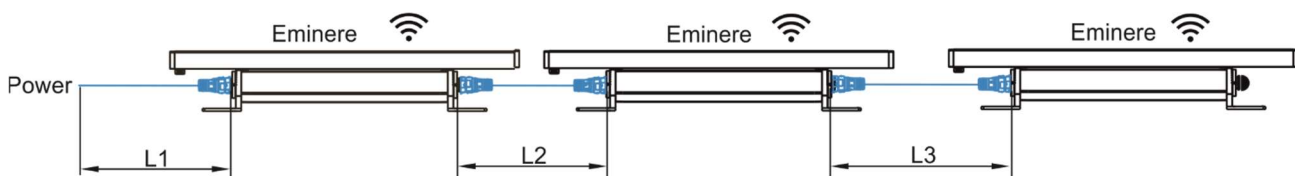

3.3 The Booster box

To compensate a voltage drop in a large installation, the Booster boxes have to be connected in the chain of Emineres.

The following tables give numbers of Emineres after which the Booster box has to be installed in the chain of Emineres.

EMINERE 2 Wireless DMX	Max. possible number of Emineres 2 Wireless DMX = 32			
	Voltage			
Cable length	120V	190V	230V	277V
10 m	-	-	-	-

Eminere Wireless DMX

20 m	-	-	-	-
30 m	28	-	-	-
50 m	17	-	-	-
70 m	12,24,	31	-	-
100 m	9,18	21	31	

EMINERE 3 Wireless DMX	Max. possible number of Emineres 3 Wireless DMX = 32			
	Voltage			
Cable length	120V	190V	230V	277V
10 m	28	-	-	-
20 m	28	-	-	-
30 m	19	-	-	-
50 m	12,24	29	-	-
70 m	8,16,24	21	31.	-
100 m	6,12,18,24,30	15,30	21	31

EMINERE 4 Wireless DMX	Max. possible number of Emineres 4 Wireless DMX = 32			
	Voltage			
Cable length	120V	190V	230V	277V
10 m	21	-	-	-
20 m	21	-	-	-
30 m	15,30	-	-	-
50 m	9,18,27	22	-	-
70 m	6,12,18,24,30	16	23	-
100 m	4,8,12,16,20,24,28	11,22	16	23

Example: E-box Daisy, Power supply= 120V, Cable length=70m, fixture=Eminere 2 wireless DMX
The Booster box has to be connected after every 12th Eminere 2 wireless DMX (fixture 12 and fixture 24) from 32 fixtures.

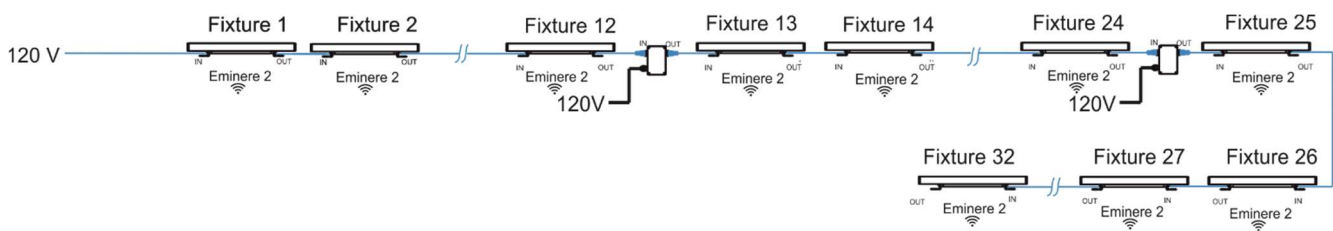

3.4 The Booster box installation

ALWAYS DISCONNECT THE EMINERES FROM MAINS BEFORE CONNECTING/DISCONNECTING THE BOOSTER BOX.

The Booster box falls under protection class I. Therefore, every Booster box has to be connected to a mains socket outlet with a protective earthing connection.

1. Unscrew the four screws (1) from the cover (2) on the Booster box to get access to the terminal block (3) and two mounting holes of diameter of 4.6 mm (4).
2. Screw the Booster box on a non-flammable flat surface and connect cables.

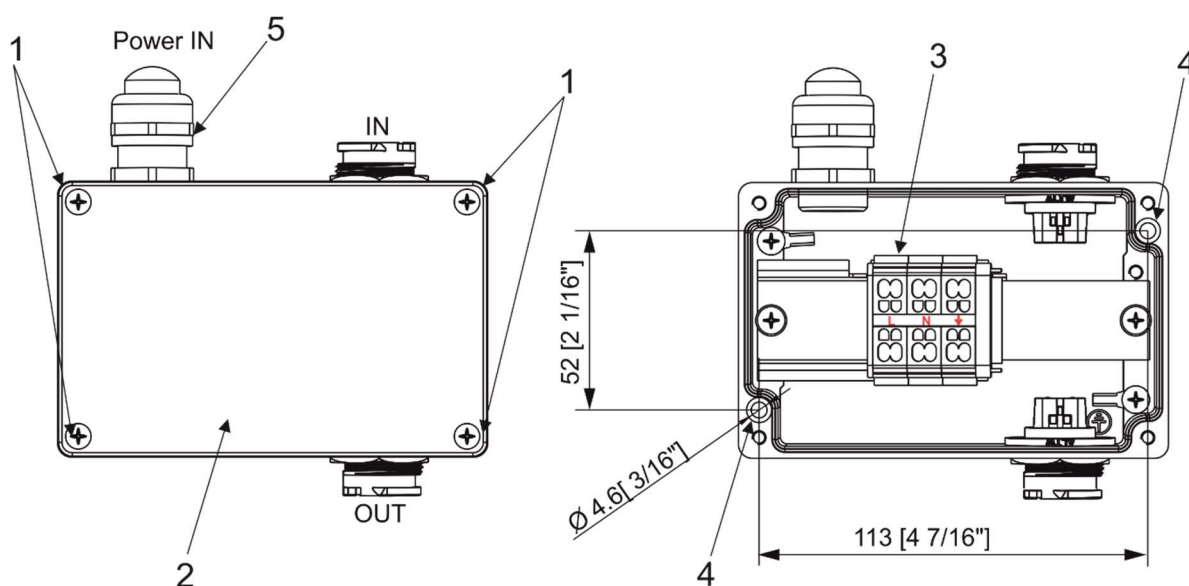

The Cable gland M20x1.5 for Power IN (5) is intended for a cable of a diameter of 7-13mm. Remove the end cap from the cable gland before passing the cable.

Power connection

	L	N	⏏ (earth)
Core (EU)	Braun	Blue	Green/yellow
Core (US)	Black	White	Green

We recommend to apply an adequate layer of the paste LOCTITE 5331 on the plastic holder of the cable gland before inserting it into the body of the gland and an adequate layer of the paste LOCTITE 577 on the thread of the gland body in case of unscrewing the cable gland from the housing of the buster box and repeatedly screwing it back to the housing .

Cable gland M20 MS:

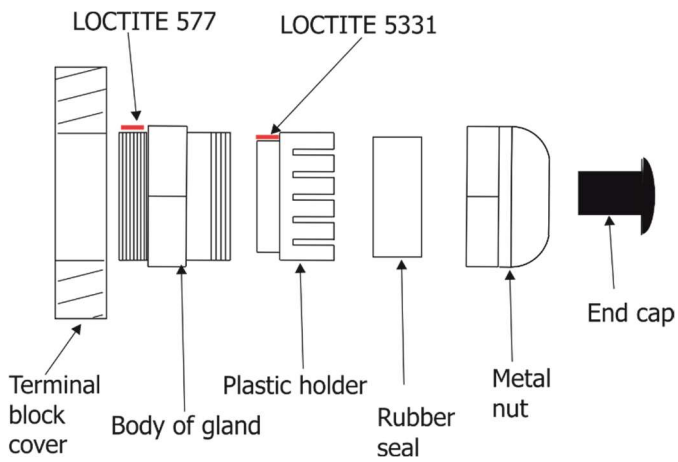

The cable gland M20 MS with a standard seal serves for a cable of diameter of 6-12mm, for smaller diameter of cable (4-8mm) you have to remove the original seal from the cable gland M20 and use the enclosed reducing seal instead of it. The reducing seal for diameter of cable 4-8mm (P/N 13051388) is enclosed in the Booster box.

1 x standard seal - part of cable gland M20 MS
(for diameter of cable: 6-12mm)

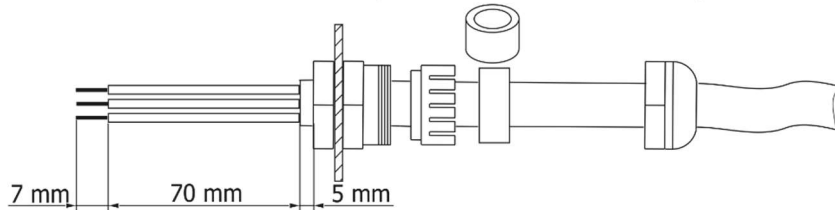

1 x reducing seal (P/N 13051388) - enclosed, standard seal
has to be removed before installing this seal.
(for diameter of cable: 4-8mm)

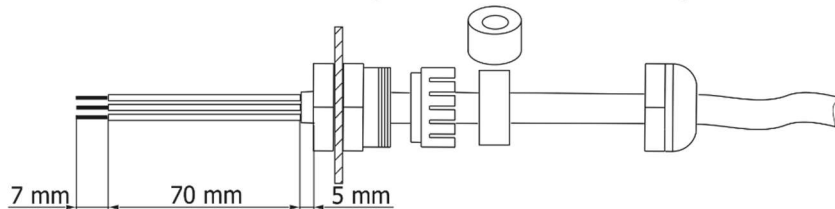

3. Screw the cover (2) back on the Booster box.

3.5 Jumper cable assembling

1. Dismantle the connector and slide its parts onto the cable (6).
Use the seal with inner diameter of 14.5 mm for the Anolis cable (P/N 13053138 or P/N 13053139).
The seal with inner diameter of 14.5 mm serves for cable of diameter 10-14.5mm.
The seal with inner diameter of 10 mm serves for cable of diameter 8-10mm.

Parts of the connector

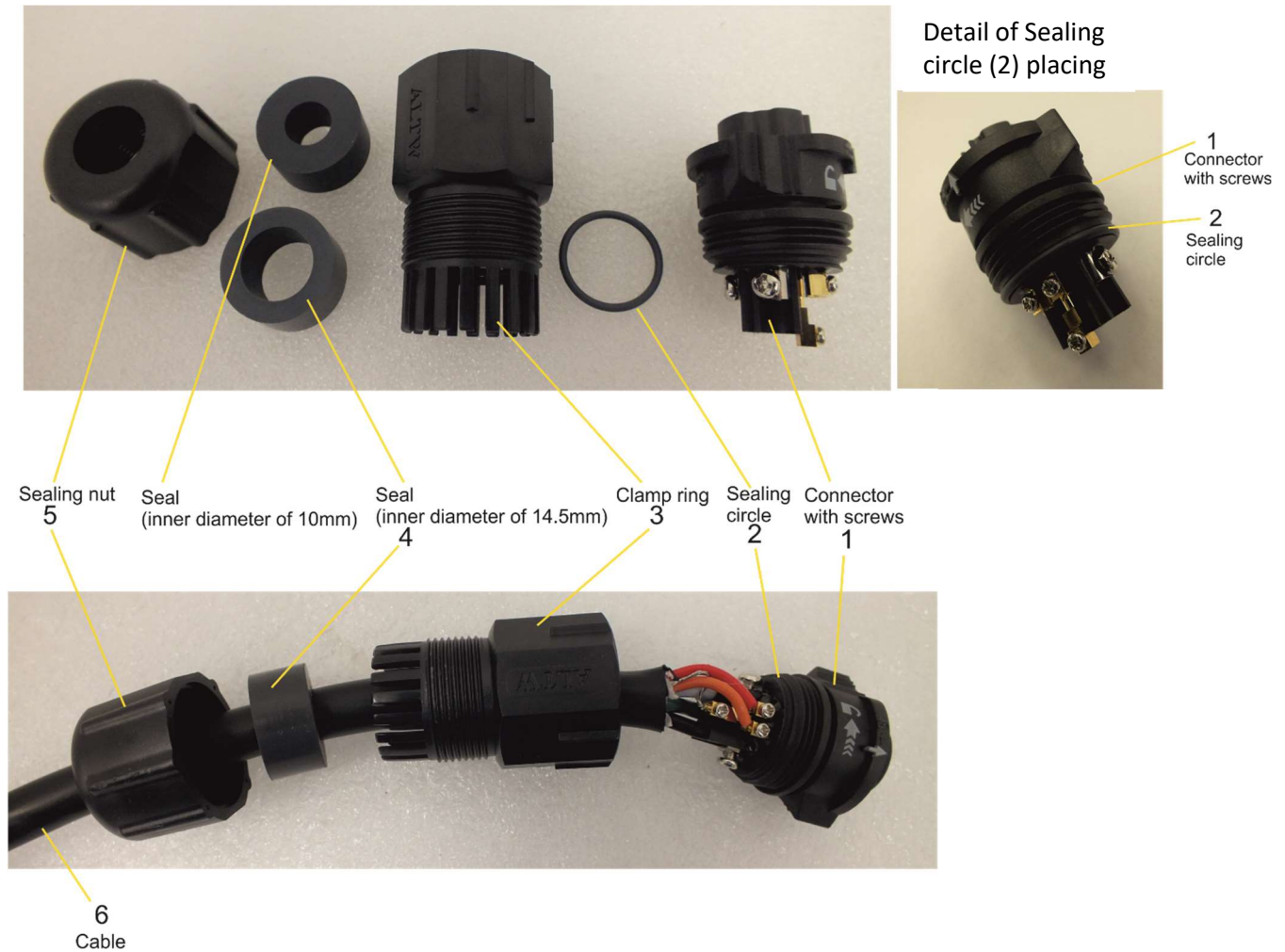

2. Put the sealing circle (2) on the connector with screws (1).
3. Remove insulation from the cable (6) and from individual wires and fasten three terminals on data wires.

CE version

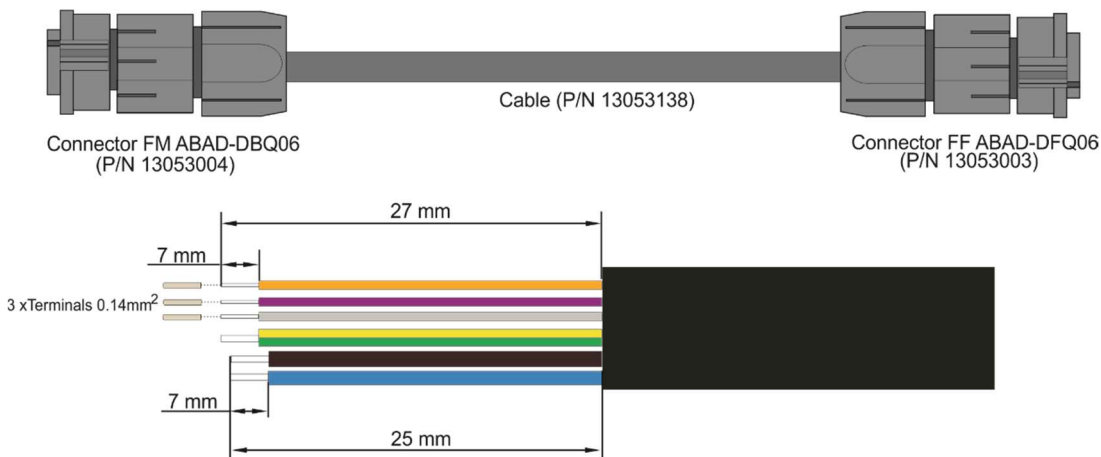

Eminere Wireless DMX

US version

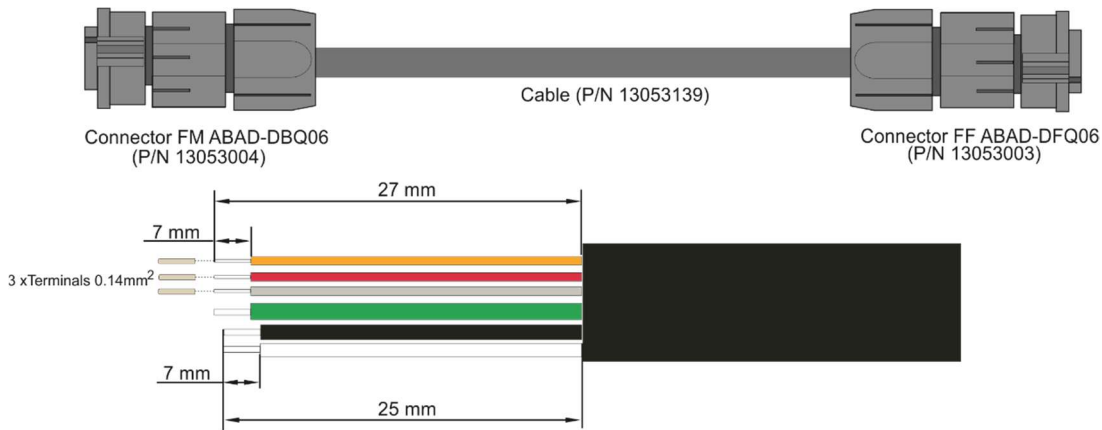

4. Put parts of the connector on the cable (6) and connect wires to the connector. First connect power wires (L,N, Earth) and after that data wires (D+, D-, 0V). Avoid excessive torsion of data wires!

CE version

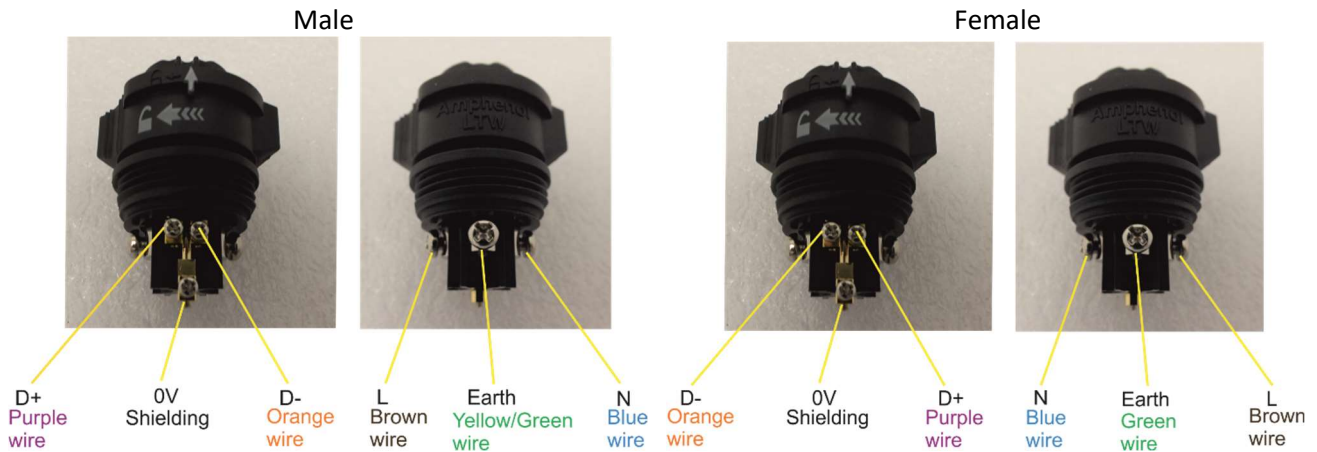

US version

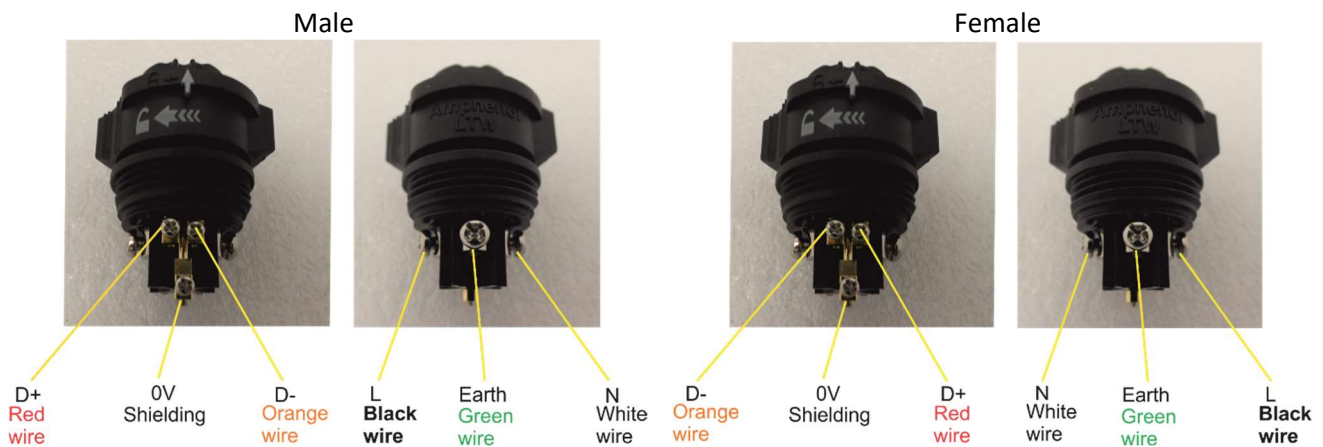

5. After connecting wires to the connector, tighten the three data wires (D+,D-, 0V) by means of the cable binder (7).



7
Cable binder

6. Screw the clamp ring (3) to the connector (1), insert the seal (4) to the clamp ring (3) and tighten the sealing nut (5) enough. During the steps DO NOT TWIST the cable (6).

7. Use the same procedure to assemble the connector on the second end of the cable.

IMPORTANT

Do not bend the cable near to the connector, minimum distance for bending is 50mm.

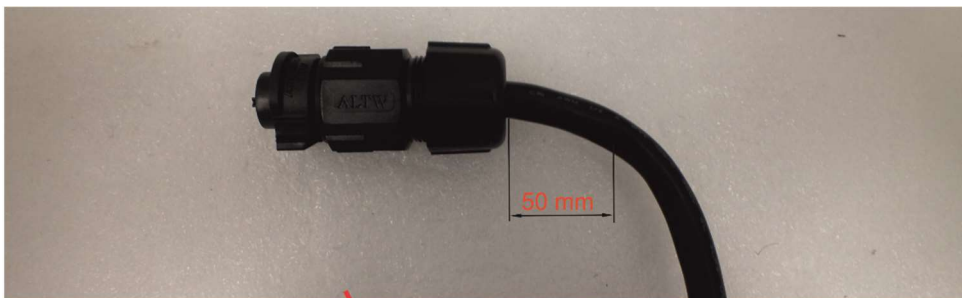

4. Technical specifications

Power supply

- Electronic auto-ranging
- Input voltage: 120 - 277V AC, 50/60 Hz
- Power consumption:
 - Eminere 2: 45W
 - Eminere 3: 65W
 - Eminere 4: 85W
- Inrush current:
 - Eminere 2: <70A/250µs
 - Eminere 3: <100A/200µs
 - Eminere 4: <100A/200µs

Optic

- Light source:
 - Eminere 2: 24 x high power LEDs
 - Eminere 3: 36 x high power LEDs
 - Eminere 4: 48 x high power LEDs
- Colour variants: RGBW, RGBA, single colour
- Beam Angle:
 - Symmetrical: 9°, 15°, 30°, 50°, 65°, 100°
 - Bi-symmetrical: 10° x 30°, 30° x 10°, 10° x 60°, 60° x 10°, 35° x 70°, 70° x 35°, 15° x 90°, 90° x 15°
 - Wallwasher, Wide Wallwasher
- Projected Lumen Maintenance: L90B10 >90.000 hrs, Ta = 25°C / 77°F

Mounting method

- Via two L-shape brackets
- LED module "tilt" adjustment range: -95°/+95°

Sizes

- Eminere 2 (600mm / 2ft)
- Eminere 3 (900mm / 3ft)
- Eminere 4 (1200mm / 4ft)

Housing

- Aluminium extruded body with die-casted end caps
- Tempered glass

Cooling system

- Convection

Total heat dissipation

- Eminere 2: 130 BTU/h (calculated)
- Eminere 3: 177 BTU/h (calculated)
- Eminere 4: 228 BTU/h (calculated)

Protection factor

- CE: IP 67
- US: Suitable for wet location

Impact rating

- CE: IK06

Eminere Wireless DMX

Operating ambient temperature range

- -20°C /+40°C (-4°F /+104°F)

Operating temperature

- +67°C @ Ambient +40°C (+153°F @ Ambient +104°F)

Connection

- Input: panel connector Amphenol ABAB-DMQ06000021-IN (P/N13052952)
- Output: panel connector Amphenol ABAB-DAQ06000021 (P/N13052953) + water-tight cap

Weight

- Eminere 2: 4 kg (8.82 lbs)
- Eminere 3: 6.02 kg (13.27 lbs)
- Eminere 4: 7.7 kg (17 lbs)

Dimensions (All dimensions in mm [inch])

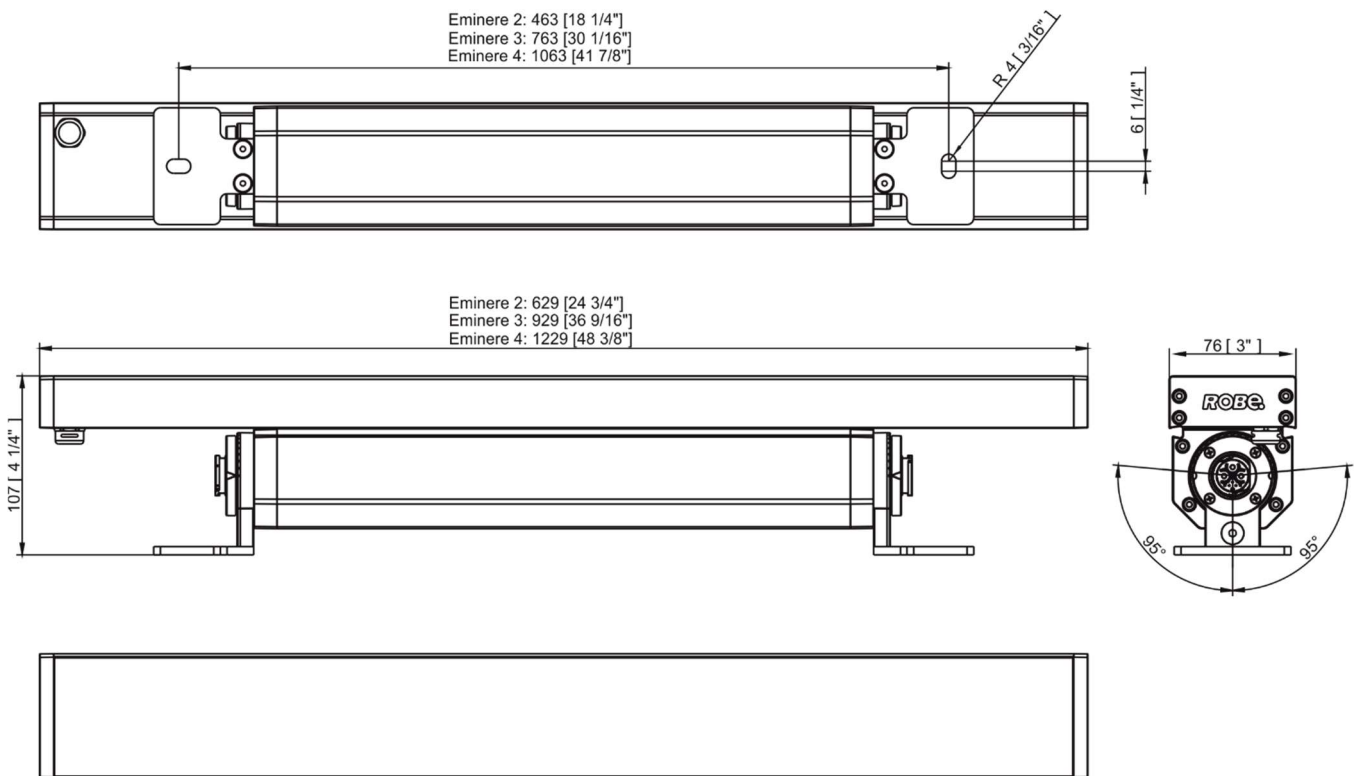

• Booster box

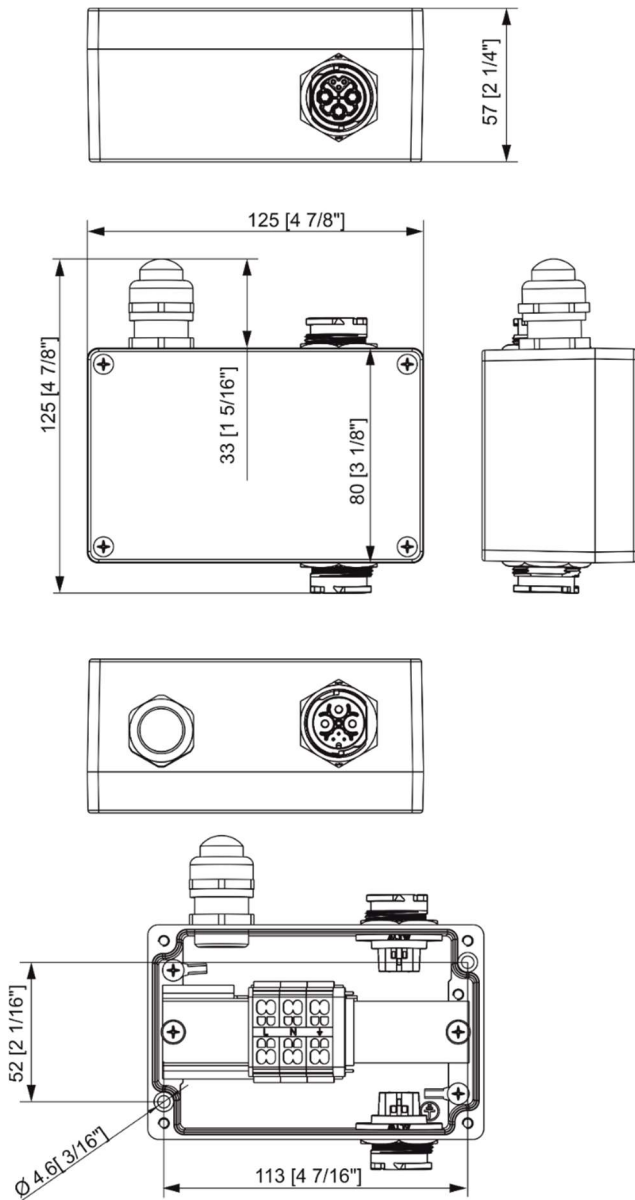

Included items

- 1 x Eminere
- 1 x User manual

Optional accessories

Jumper Cables FF/FM:

- Jumper Cable FF/FM 0,25m (P/N 13053052)
- Jumper Cable FF/FM 0,5m (P/N 13053053)
- Jumper Cable FF/FM 1m (P/N 13053054)
- Jumper Cable FF/FM 2m (P/N 13053055)
- Jumper Cable FF/FM 3m (P/N 13053056)
- Jumper Cable FF/FM 5m (P/N 13053057)
- Jumper Cable FF/FM 10m (P/N 13053058)

Waterproof Cover Cap FM ZAHB-0006 (P/N 17031173)

Field Installable Connector FF (P/N 13053003)

Field Installable Connector FM (P/N 13053004)

Cable Cover for Eminere 2 RAL9011 (P/N 10980485)
 Cable Cover for Eminere 3 RAL9011 (P/N 10980486)
 Cable Cover for Eminere 4 RAL9011 (P/N 10980487)

Shield for Eminere 2 RAL9011 (P/N 10980489)
 Shield for Eminere 3 RAL9011 (P/N 10980490)
 Shield for Eminere 4 RAL9011 (P/N 10980491)

Mounting Brackets for Eminere 100mm, 2pcs RAL9011 (P/N 10980493)
 Mounting Brackets for Eminere 200mm, 2pcs RAL9006 (P/N 10980529)
 Mounting Brackets for Eminere 200mm, 2pcs RAL9011 (P/N 10980494)
 Mounting Brackets for Eminere 300mm, 2pcs RAL9006 (P/N 10980576)
 Mounting Brackets for Eminere 300mm, 2pcs RAL9011 (P/N 10980495)
 Mounting Brackets for Eminere 50mm, 2pcs RAL9011 (P/N 10980525)

5. Cleaning and maintenance

DANGER !
Disconnect from the mains before starting any maintenance or cleaning work

Rinse off loose dirt with low pressure water spray. Wash the housing with a soft brush or sponge and a mild, non-abrasive washing detergent. Rinse it.

Maintenance and service operations are only to be carried out by a qualified person.

Should you need any spare parts, please use ROBE OEM parts.

5.1 Disposing of the product

To preserve the environment please dispose or recycle this product at the end of its life according to the local regulations and codes.

6. ChangeLog

This section summarizes changes in the user manual.

Version of manual	Date of issue	Description of changes
1.1	07/09/2021	Option Wireless DMX to wired DMX removed
1.2	05/10/2021	New DMX chart
1.3	13/10/2021	Technical specifications changed
1.4	26/11/2021	Optional accessories changed
1.5	20/12/2021	Jumper cable mounting added
1.6	06/01/2022	Jumper cable mounting chaged
1.7	12/01/2022	Jumper cable mounting more specified
1.8	23/02/2022	Sealing circle added to jumper cable mounting
1.9	19/05/2022	QR code added

Specifications are subject to change without notice.

May 19, 2022

Copyright © 2019-2022 Robe Lighting - All rights reserved

Made in CZECH REPUBLIC by ROBE LIGHTING s.r.o. Palackeho 416/20 CZ 75701 Valasske Mezirici