

**Eminere Side 1**  
**Eminere Side 2**  
**Eminere Side 3**  
**Eminere Side 4**

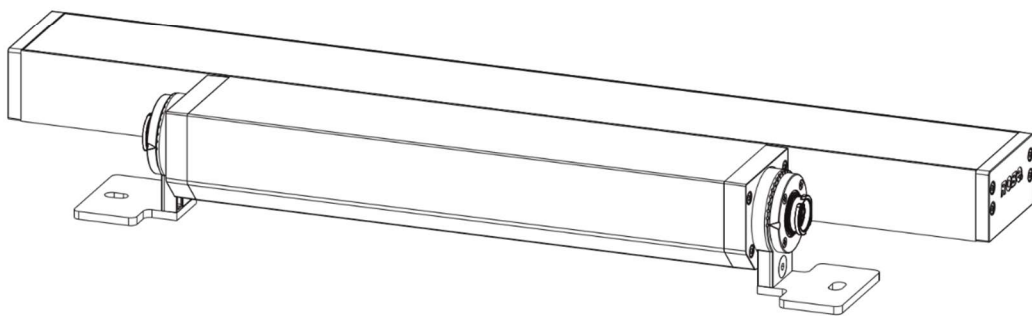

QR code for user manual



## Table of contents

1. Safety instructions .....	3
2. Fixture exterior view .....	4
3. Installation .....	5
3.1 Mounting the fixture .....	5
3.2 Connection to mains .....	5
3.3 The Booster box .....	9
3.4 The Booster box installation .....	12
3.5 Jumper cable assembling .....	13
4. Technical specifications .....	16
5. Cleaning and maintenance .....	21
5.1 Disposing of the product .....	21
6. ChangeLog .....	22

**FOR YOUR OWN SAFETY, PLEASE READ THIS USER MANUAL CAREFULLY  
BEFORE POWERING OR INSTALLING YOUR Eminere Side !  
Save it for future reference.**

This device has left our premises in absolutely perfect condition. In order to maintain this condition and to ensure safe operation, it is absolutely necessary for the user to follow the safety instructions and warnings written in this manual.

The manufacturer will not accept liability for any resulting damages caused by the non-observance of this manual or any unauthorized modification to the device.

Unauthorized modification will void warranty.

## 1. Safety instructions

**DANGEROUS VOLTAGE CONSTITUTING A RISK OF ELECTRIC SHOCK IS PRESENT WITHIN THIS UNIT!**

This fixture should be operated only from the type of power source indicated on the marking label. If you are not sure of the type of power supplied, consult your authorized distributor or local power company.

Always disconnect the fixture from AC power before cleaning, servicing or installing.

Make sure the data/power cable is not damaged by sharp edges. Check the fixture and the power cord from time to time.

Do not install the unit near an open flame.

During operation the housing becomes hot.

Refer servicing to qualified service personnel.

**This fixture falls under protection class I. Therefore this fixture has to be connected to a mains socket outlet with a protective earthing connection.**

Do not connect this fixture to a dimmer pack.

***LED light emission. Risk of eye injury. Do not look into the beam from a short distance without suitable protective eyewear. Do not look at LEDs with magnifiers or similar optical instruments that may concentrate the light output.***

The fixture was designed for outdoor use. This fixture must not be used for underwater installation.

When choosing the installation spot, please make sure that the fixture is not exposed to extreme heat or dust.

Avoid using the unit in locations subject to possible impacts.

The fixture body never must be covered with cloth or other materials when the fixture is under operation.

Only operate the fixture after having checked that the housing is firmly closed and all screws are tightly fastened.

The fixture becomes hot during operation. Allow the fixture to cool approximately 30 minutes prior to servicing or maintenance.

Operate the fixture only after having familiarized yourself with its functions. Do not permit operation by persons not qualified to operate the fixture. Most damages are the result of unprofessional operation!

Immunity of the equipment is designed for electromagnetic environments E1, E2, E3 according to the standard EN55103-2 ed.2 Electromagnetic compatibility. Product family standard for audio, video, audiovisual and entertainment lighting control apparatus for professional use. Part 2: Immunity.

The installation company should check levels of possible interferences above the tested levels E1,E2,E3 given by this standard (e.g. transmitters in surrounding area) before installing the equipment.

Emission of the equipment complies with the standard EN55032 Electromagnetic compatibility of multimedia equipment – Emission Requirements according to class B.

Please consider that unauthorized modifications on the fixture are forbidden due to safety reasons!

Please use the original packaging if the fixture is to be transported.

If this device will be operated in any way different to the one described in this manual, the product may suffer damages and the warranty becomes void. Furthermore, any other operation may lead to dangers like short-circuit, burns, electric shock etc.

## 2. Fixture exterior view

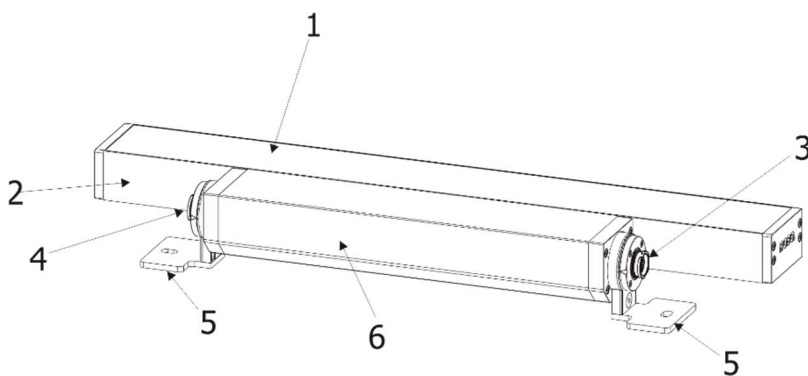

1. Transparent glass cover
2. LED module
3. Input connector
4. Output connector
5. Mounting brackets
6. Aluminium base

### 3. Installation

#### 3.1 Mounting the fixture

The Eminere Side can be arranged in any orientation on a flat, non-flammable surface by means of two mounting brackets (5), the LED module (2) can be tilted 120° to adjust desired beam position.

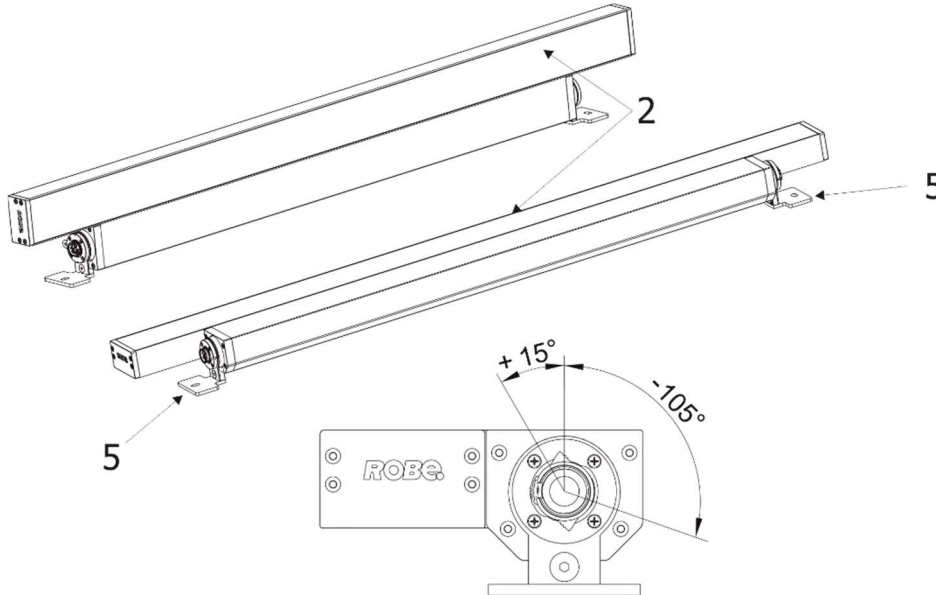

**Ensure that the structure to which you are attaching the unit is secure.**

#### 3.2 Connection to mains

**The unit must be installed by a qualified electrician in accordance with all national and local electrical and construction codes and regulations.  
This device falls under class one and must be grounded!**

The Eminere Side is equipped with auto-switching power supply that automatically adjusts to any 50-60Hz AC power source from 120-277 Volts.

Wiring of input/output connectors:

**Input - panel connector**  
(front view)

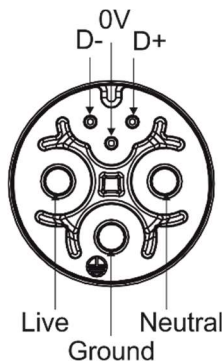

**Output - panel connector**  
(front view)

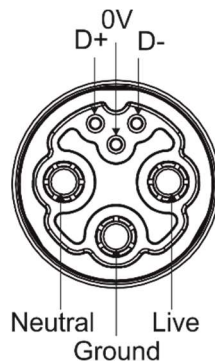

Fixture's Amphenol connectors are dust and water protected according to IP 67 by mating with related Amphenol connectors.

## Eminere Side

They cannot stay disconnected outdoor.

**The output panel connector at last fixture in the Eminere Side chain has to always be covered with the water-tight cap to keep declared IP rating.**

The Eminere modules should be connected to the E-box which allows power supply of the Eminere modules and their control.

***Do not connect (disconnect) Eminere Sides to the E-box or Booster box and each other when they are under voltage!***

***When you change any setting of the E-box, disconnect the E-box from power and connect it to power again to activate changes which you have made.***

Examples of connection for various versions of the E-box.

Please read the E-box user manual for more information about its setting and connection to Eminere modules. Needed cables are stated in the chapter "Technical information".

### E-box Daisy

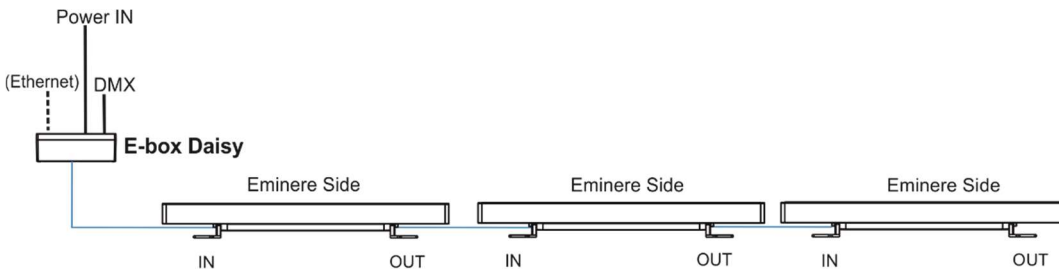

### E-box Star



# Eminere Side

## E-box Pro

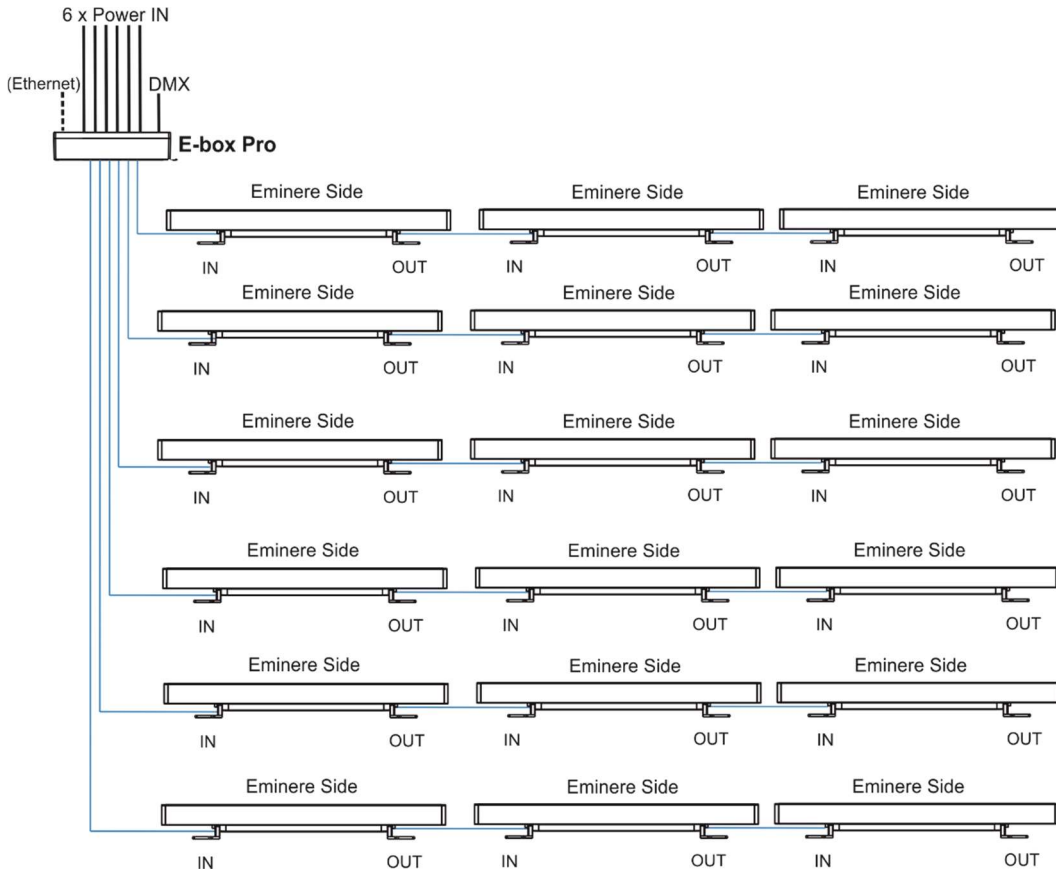

## E-box Lite

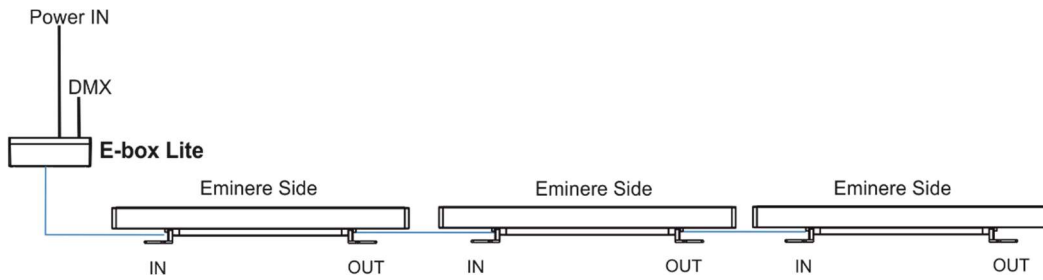

Number of connected Emineres Side to one E-box output depends on a cable length, power voltage, type of and E-box.

### Eminere Side

The tables below state max. theoretical number of Emineres connected to the one LED output of the E-box without Booster boxes. The following tables apply for the Standard mode of E-boxes

<b>EMINERE SIDE 1</b>	<b>Voltage</b>			
<b>Cable length *</b>	<b>120V</b>	<b>190V</b>	<b>230V</b>	<b>277V</b>
10 m	83	131	159	191
20 m	83	131	159	191
30 m	58	131	159	191
50 m	35	88	128	186
70 m	25	63	92	133
100 m	17	44	64	93
200 m	9	22	32	47

<b>EMINERE SIDE 2</b>	<b>Voltage</b>			
<b>Cable length *</b>	<b>120V</b>	<b>190V</b>	<b>230V</b>	<b>277V</b>
10 m	41	64	78	94
20 m	41	64	78	94
30 m	28	64	78	94
50 m	17	43	63	91
70 m	12	31	45	65
100 m	9	21	31	46
200 m	4	11	16	23

<b>EMINERE SIDE 3</b>	<b>Voltage</b>			
<b>Cable length *</b>	<b>120V</b>	<b>190V</b>	<b>230V</b>	<b>277V</b>
10 m	28	44	53	64
20 m	28	44	53	64
30 m	19	44	53	64
50 m	12	29	43	62
70 m	8	21	31	44
100 m	6	15	21	31
200 m	3	7	11	16



Eminere Side

EMINERE SIDE 4	Voltage			
	120V	190V	230V	277V
Cable length *				
10 m	21	33	40	48
20 m	21	33	40	48
30 m	15	33	40	48
50 m	9	22	32	47
70 m	6	16	23	38
100 m	4	11	16	23
200 m	2	5	8	12

\* Cable length is a total cable length between E-box and last connected Eminere Side.

Example: Total cable length=L1+L2+L3

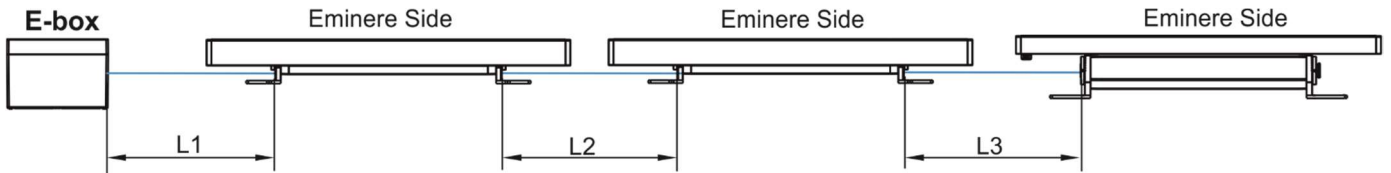

**Notice for the E-box Star:** The tables above state max. total number of Emineres Side connected to 6 LED outputs of the E-box Star (or max. number of Emineres Side connected to one output if the rest of outputs is not connected). The E-box Star has only one power input!

The table below states max. number of Emineres Side connected to the one LED output of the E-box using Booster boxes (which compensate a voltage drop) regardless voltage and cable length.

### 3.3 The Booster box

To compensate a voltage drop in large installation, the Booster boxes have to be connected in the chain of Emineres Side at every LED output of the E-box.

The following tables give numbers of Emineres Side after which the Booster box has to be installed in the chain of Emineres Side (at one LED output of the E-box). The following tables apply for the Standard mode of E-boxes.

EMINERE SIDE 1	Max. number of Emineres 1= 191			
	Voltage			
Cable length	120V	190V	230V	277V
10 m	83,166	131	159	-
20 m	83,166	131	159	-
30 m	58,116,174	131	159	-
50 m	35,70,105,140,175	88,176	128	186

Eminere Side

70 m	25,50,75,100,125,150,175	63,126,189	92,184	133
100 m	17,34,51,68,85,102,119,136,153,170,187	44,88,132,176	64,128	93,186
200 m	9,18,27,36,45,54,60,72,81,90,99,108,117,126,135,144,153,162,171,180,189,	22,44,66,88,110,132,154,176	32,64,96,128,160	47,94,141,188

EMINERE SIDE 2	Max. number of Emineres 2= 94			
	Voltage			
Cable length	120V	190V	230V	277V
10 m	41,82	64	78	-
20 m	41,82	64	78	-
30 m	28,56,84	64	78	-
50 m	17,34,51,68,85	43,86	63	91
70 m	12,24,36,48,60,72,84	31,62,93	45,90	65
100 m	9,18,27,36,45,54,60,72,81,90	21,42,63,84	31,62,93	46,92
200 m	4,8,12,16,20,24,28,32,36,40,44,48,52,56,60,64,68,72,76,80,84,88,92	11,22,33,44,55,66,77,88	16,32,48,64,80	23,46,69,92

EMINERE SIDE 3	Max. number of Emineres 3= 64			
	Voltage			
Cable length	120V	190V	230V	277V
10 m	28,56	44	53	-
20 m	28,56	44	53	-
30 m	19,38,57	44	53	-
50 m	12,24,36,48,60	29,58	43	62
70 m	8,16,24,32,40,48,56	21,42,63	31,62	44
100 m	6,12,18,24,30,36,42,48,54,60	15,30,45,60	21,42,63	31,62
200 m	3,6,9,12,15,18,21,24,27,30,33,36,39,42,45,48,51,54,57,60,63	7,14,21,28,35,42,49,56,63	11,22,33,44,55	16,32,48,

Eminere Side

EMINERE SIDE 4	Max. number of Emineres 4= 48			
	Voltage			
Cable length	120V	190V	230V	277V
10 m	21,42	33	40	-
20 m	21,42	33	40	-
30 m	15,30,45	33	40	-
50 m	9,18,27,36,45	22,44	32	47
70 m	6,12,18,24,30,36,42	16,32	23,46	38
100 m	4,8,12,16,20,24,28,32,36,40,44	11,22,33,44	16,32	23,46
200 m	2,4,6,8,10,12,14,16,18,20,22,24,26,28,30,32,34,36,38,40,42,44,46	5,10,15,20,25,30,35,40,45	8,16,24,32,40	12,24,36

Example: E-box Daisy, Power supply= 230V, Cable length=70m, fixture=Eminere Side 2  
 The Booster box has to be connected after every 45th Eminere Side 2 (fixture 45 and fixture 90) from 94 fixtures.

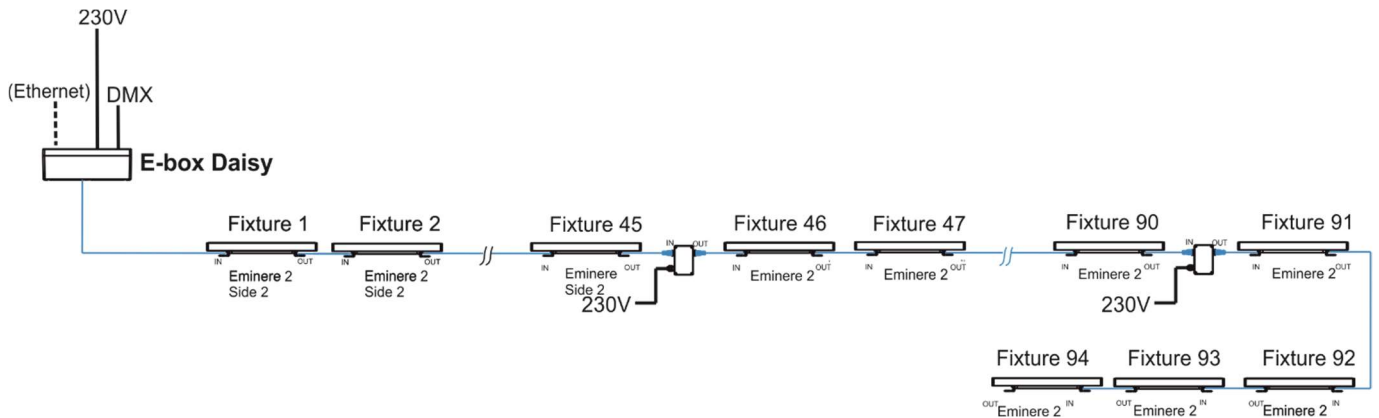

### 3.4 The Booster box installation

**ALWAYS DISCONNECT THE EMINERES SIDE FROM MAINS BEFORE CONNECTING/DISCONNECTING THE BOOSTER BOX.**

**The Booster box falls under protection class I. Therefore, every Booster box has to be connected to a mains socket outlet with a protective earthing connection.**

1. Unscrew the four screws (1) from the cover (2) on the Booster box to get access to the terminal block (3) and two mounting holes of diameter of 4.6 mm (4).
2. Screw the Booster box on a non-flammable flat surface and connect cables.

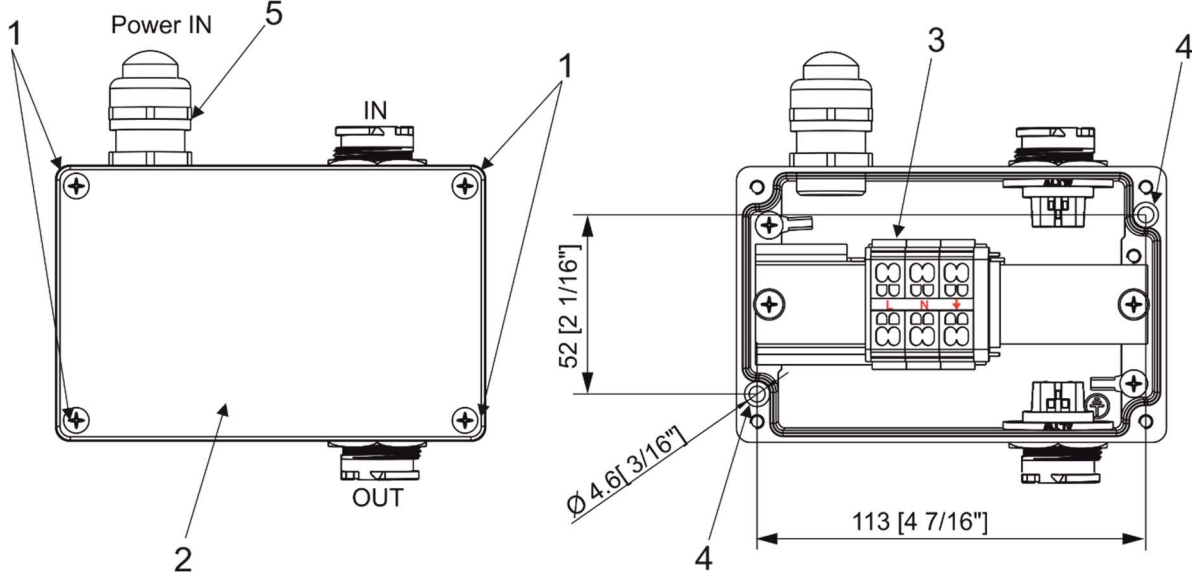

The Cable gland M20x1.5 for Power IN (5) is intended for a cable of a diameter of 7-13mm. Remove the end cap from the cable gland before passing the cable.

**Power connection**

	<b>L</b>	<b>N</b>	<b>⊕ (earth)</b>
Core (EU)	Braun	Blue	Green/yellow
Core (US)	Black	White	Green

We recommend to apply an adequate layer of the paste LOCTITE 5331 on the plastic holder of the cable gland before inserting it into the body of the gland and an adequate layer of the paste LOCTITE 577 on the thread of the gland body.

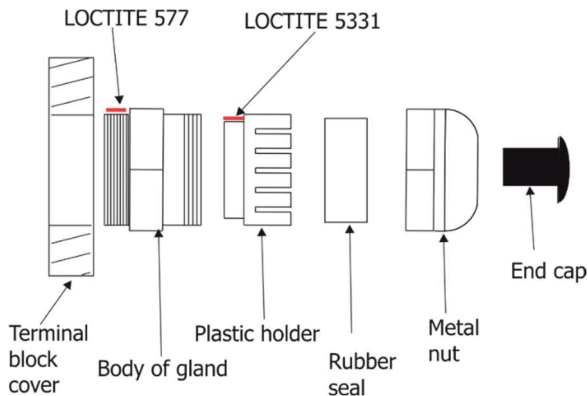

3. Screw the cover (2) back on the Booster box.

### 3.5 Jumper cable assembling

1. Dismantle the connector and slide its parts onto the cable (6).  
Use the seal with inner diameter of 14.5 mm for the Anolis cable (P/N 13053138 or P/N 13053139).  
The seal with inner diameter of 14.5 mm serves for cable of diameter 10-14.5mm.  
The seal with inner diameter of 10 mm serves for cable of diameter 8-10mm.

Parts of the connector

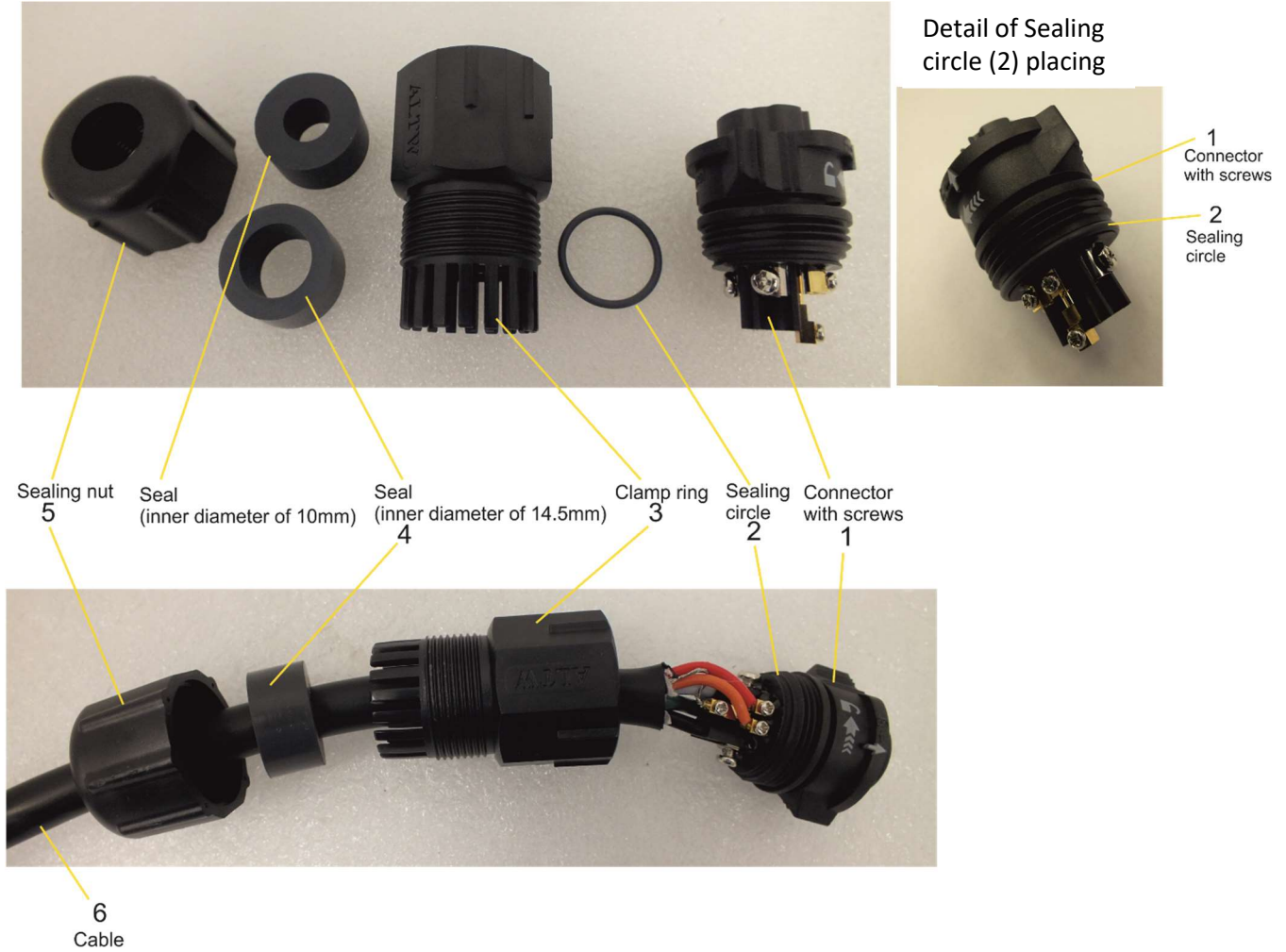

2. Put the sealing circle (2) on the connector with screws (1).
3. Remove insulation from the cable (6) and from individual wires and fasten three terminals on data wires.

CE version

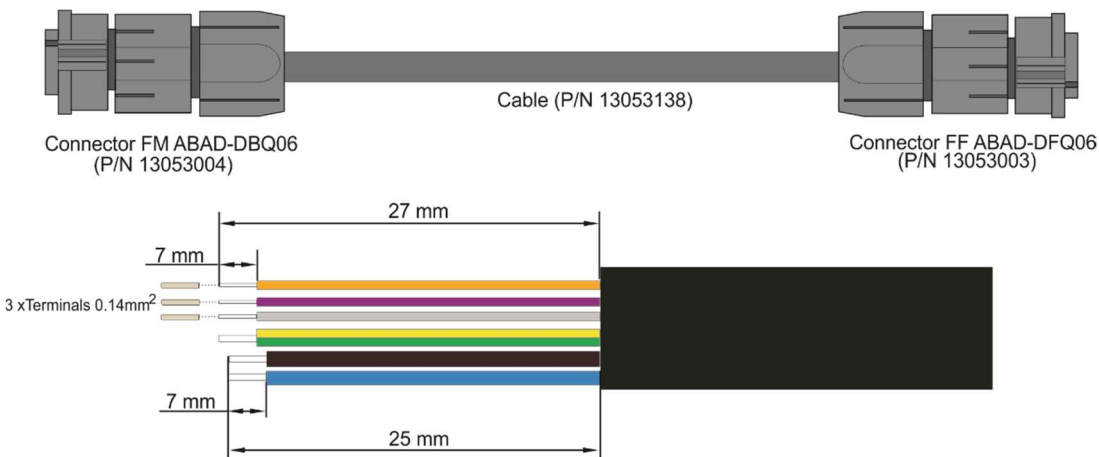

## Eminere Side

### US version

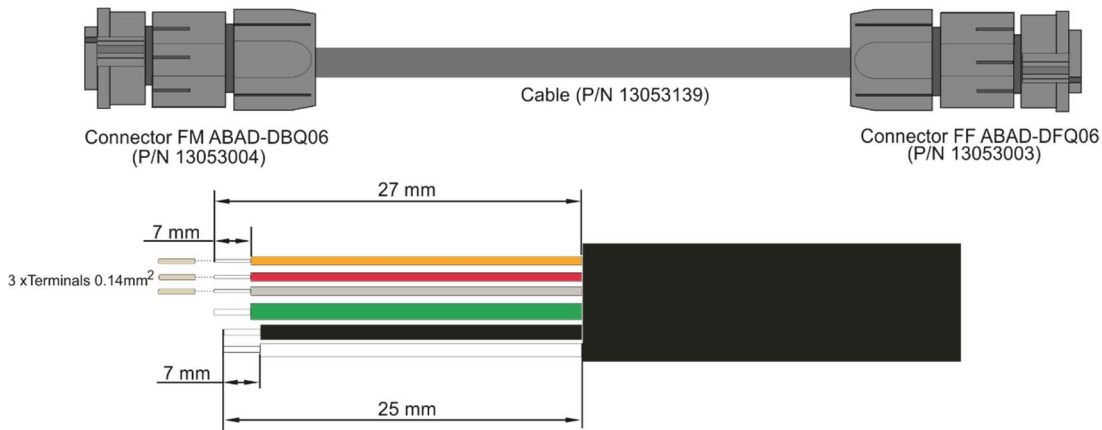

4. Put parts of the connector on the cable (6) and connect wires to the connector. First connect power wires (L,N, Earth) and after that data wires (D+, D-, 0V). Avoid excessive torsion of data wires!

### CE version

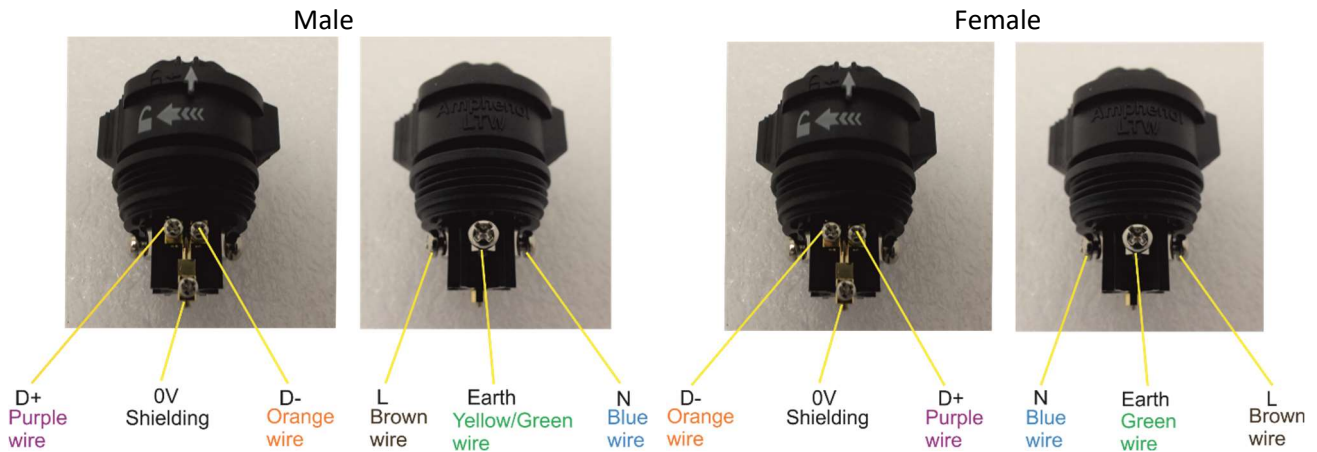

### US version

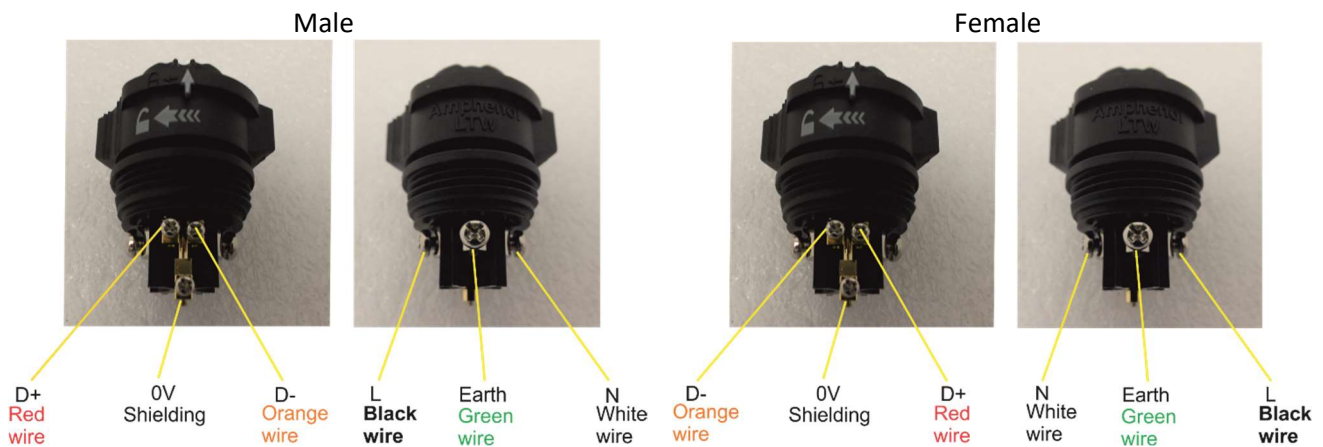

5. After connecting wires to the connector, tighten the three data wires (D+,D-, 0V) by means of the cable binder (7).



7  
Cable binder

6. Screw the clamp ring (3) to the connector (1), insert the seal (4) to the clamp ring (3) and tighten the sealing nut (5) enough. During the steps DO NOT TWIST the cable (6).

7. Use the same procedure to assemble the connector on the second end of the cable.

**IMPORTANT**

Do not bend the cable near to the connector, minimum distance for bending is 50mm.

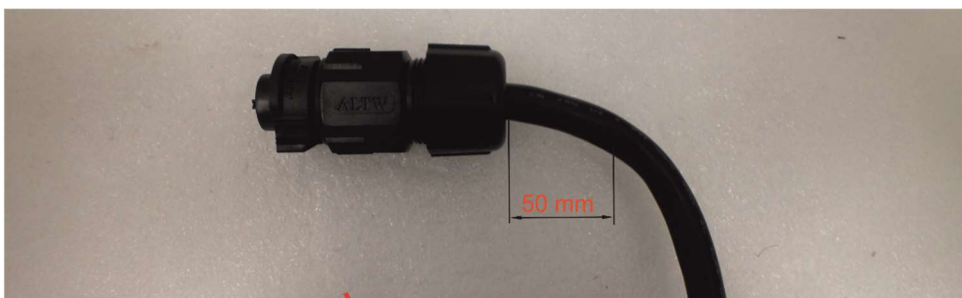

## 4. Technical specifications

### Power supply

- Electronic auto-ranging
- Input voltage: 120 - 277V AC, 50-60 Hz
- Power consumption:
  - Eminere Side 1: 25W
  - Eminere Side 2: 45W
  - Eminere Side 3: 65W
  - Eminere Side 4: 85W
- Inrush current:
  - Eminere Side 1: <70A/250µs
  - Eminere Side 2: <70A/250µs
  - Eminere Side 3: <100A/200µs
  - Eminere Side 4: <100A/200µs

### Optic

- Light source:
  - Eminere Side 1: 12 x high power LEDs
  - Eminere Side 2: 24 x high power LEDs
  - Eminere Side 3: 36 x high power LEDs
  - Eminere Side 4: 48 x high power LEDs
- Colour variants: RGBW, RGBA, single colour
- Beam Angle:
  - Symetrical: 9°, 15°, 30°, 50°, 65°, 100°
  - Bi-symetrical: 10° x 30°, 30° x 10°, 10° x 60°, 60° x 10°, 35° x 70°, 70° x 35°, 15° x 90°, 90° x 15°
  - Wallwasher, Wide Wallwasher
- Projected Lumen Maintenance: L90B10 >90.000 hrs, Ta = 25°C / 77°F

### Compatible drivers

- E-box Daisy
  - 1 Output
  - 1 Main power Input
  - Control: DMX, Art-Net, sACN , W-DMX control, RDM
  - Pixel control (1px= 1ft)
  - 120-277 V Input
  - Connection via terminal blocks, inlets via grommet
  - IP67
- E-box Star
  - 6 outputs
  - 1 Main power Input
  - Control: DMX, Art-Net, sACN , W-DMX control, RDM
  - Pixel control (1px= 1ft)
  - 120-277 V Input
  - Connection via terminal blocks, inlets via grommet
  - IP67
- E-box Pro
  - 6 outputs
  - 6 Main power Inputs
  - Control: DMX, Art-Net, sACN , W-DMX control, RDM
  - Pixel control (1px= 1ft)
  - 120-277 V Input
  - Connection via terminal blocks, inlets via grommet



## Eminere Side

IP67

- E-box Lite
  - 1 output
  - 1 Main power Input
  - Control: DMX, W-DMX control, RDM
  - Pixel control (1px= 1ft)
  - 120-277 V Input
  - Connection via screw terminal blocks, inlets via grommet
  - IP67

### Protection factor

- CE: IP 67
- US: Suitable for wet location

### Impact rating

- CE: IK06

### Operating ambient temperature range

- -20°C /+40°C (-4°F /+104°F)

### Operating temperature

- +67°C @ Ambient +40°C (+153°F @ Ambient +104°F)

### Connection

- Input: panel connector Amphenol ABAB-DMQ06000021-IN (P/N13052952)
- Output: panel connector Amphenol ABAB-DAQ06000021 (P/N13052953) + water-tight cap

### Mounting method

- Via two L-shape brackets
- LED module "tilt" adjustment range: -105°/+15°

### Sizes

- Eminere Side 1 (300mm / 1ft)
- Eminere Side 2 (600mm / 2ft)
- Eminere Side 3 (900mm / 3ft)
- Eminere Side 4 (1200mm / 4ft)

### Housing

- Aluminium extruded body with die-casted end caps
- Tempered glass

### Cooling system

- Convection

### Total heat dissipation

- Eminere Side 1: 61 BTU/h (calculated)
- Eminere Side 2: 130 BTU/h (calculated)
- Eminere Side 3: 177 BTU/h (calculated)
- Eminere Side 4: 228 BTU/h (calculated)

### Weight

- Eminere Side 1: 2.95 kg (6.5 lbs)
- Eminere Side 2: 4.75 kg (10.47 lbs)

## Eminere Side

- Eminere Side 3: 7.0 kg (15.43 lbs)
- Eminere Side 4: 8.92 kg (19.67 lbs)

### Dimensions (All dimensions in mm [inch])

- Eminere Side 1

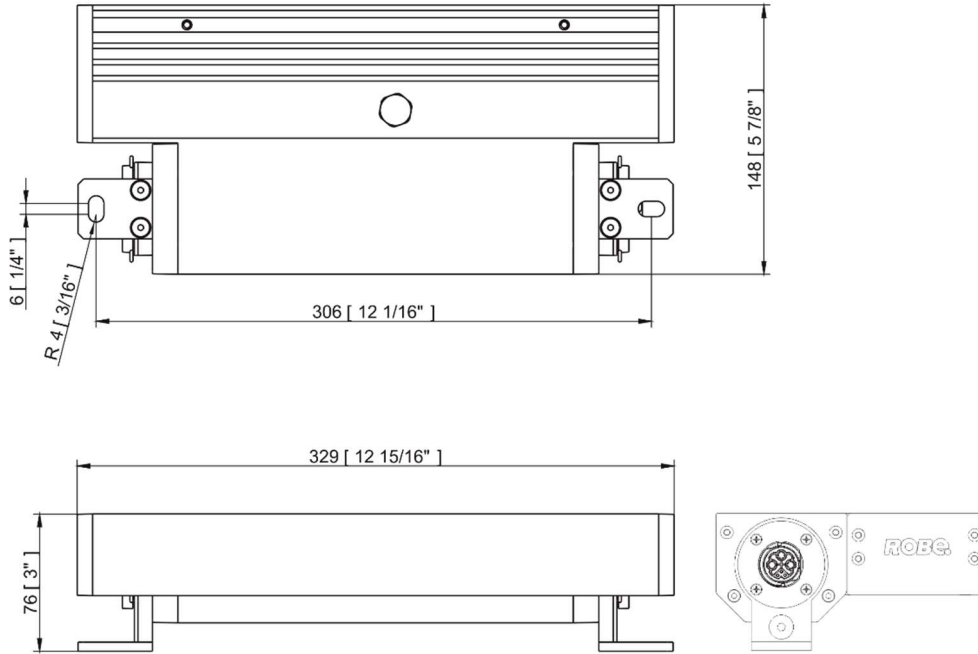

- Eminere Side 2

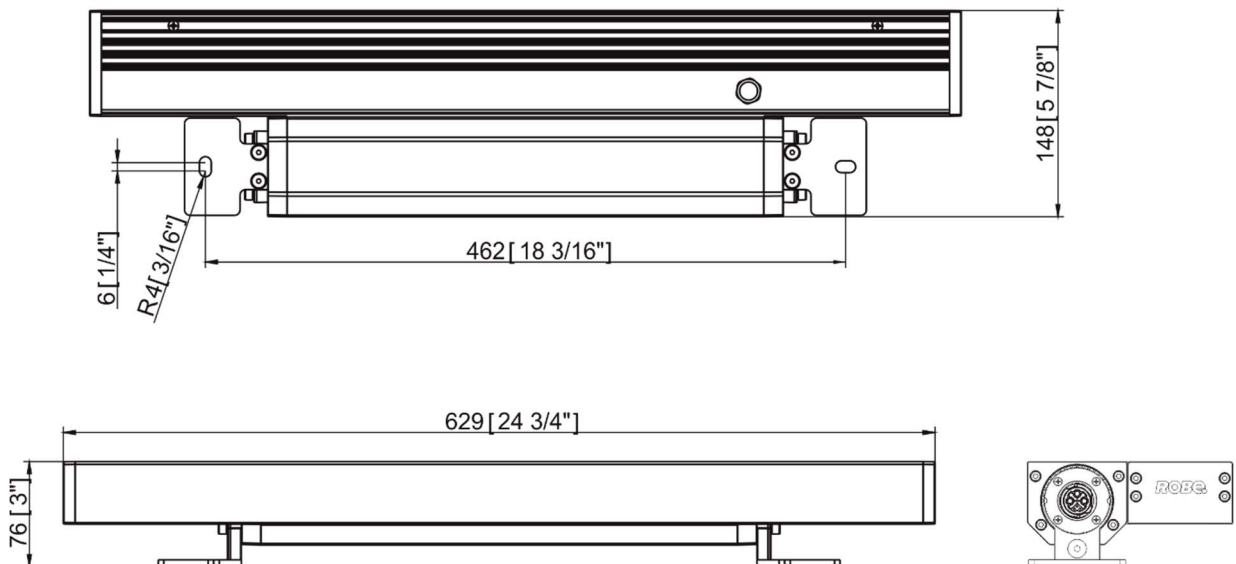

Eminere Side

• Eminere Side 3

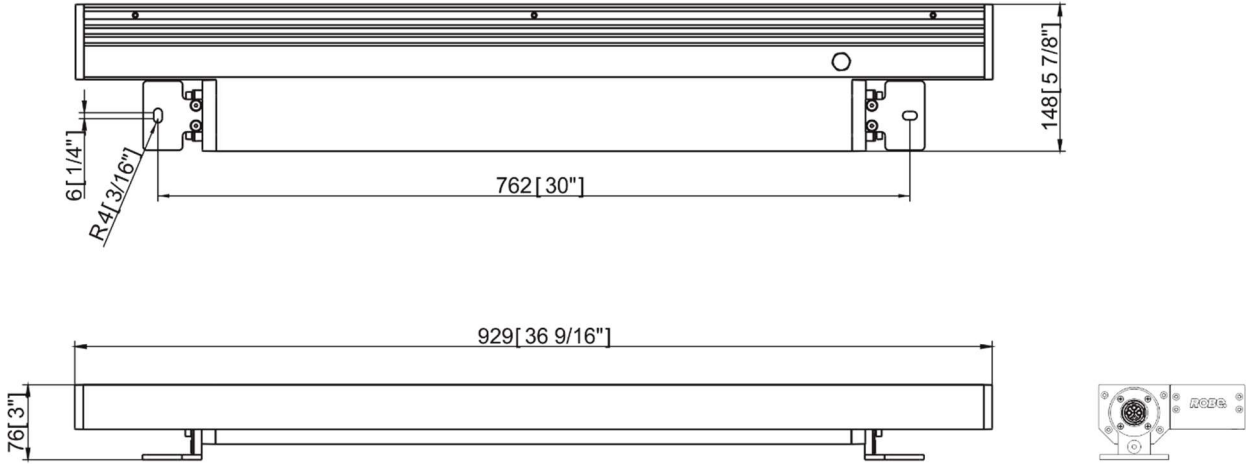

• Eminere Side 4

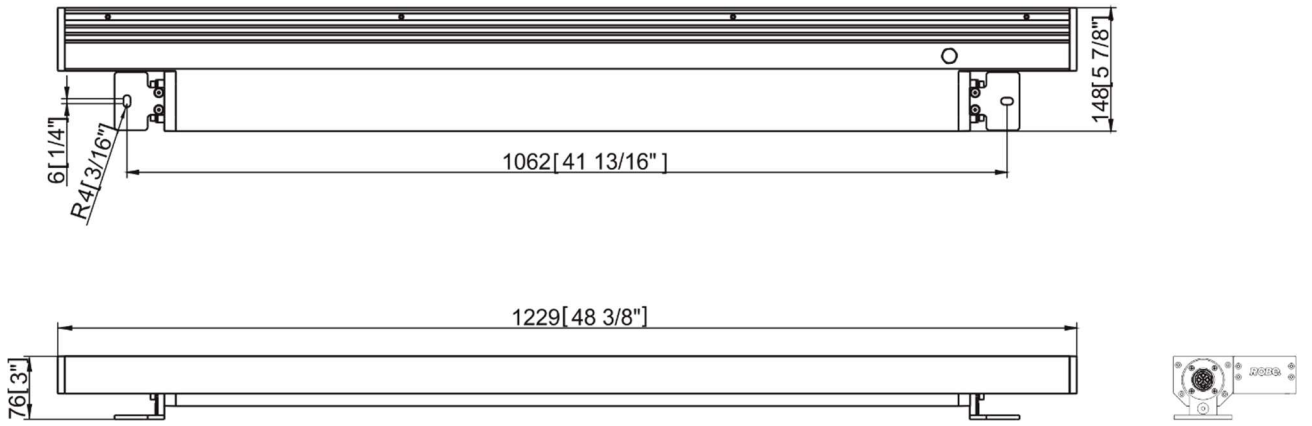

## Eminere Side

- Booster box

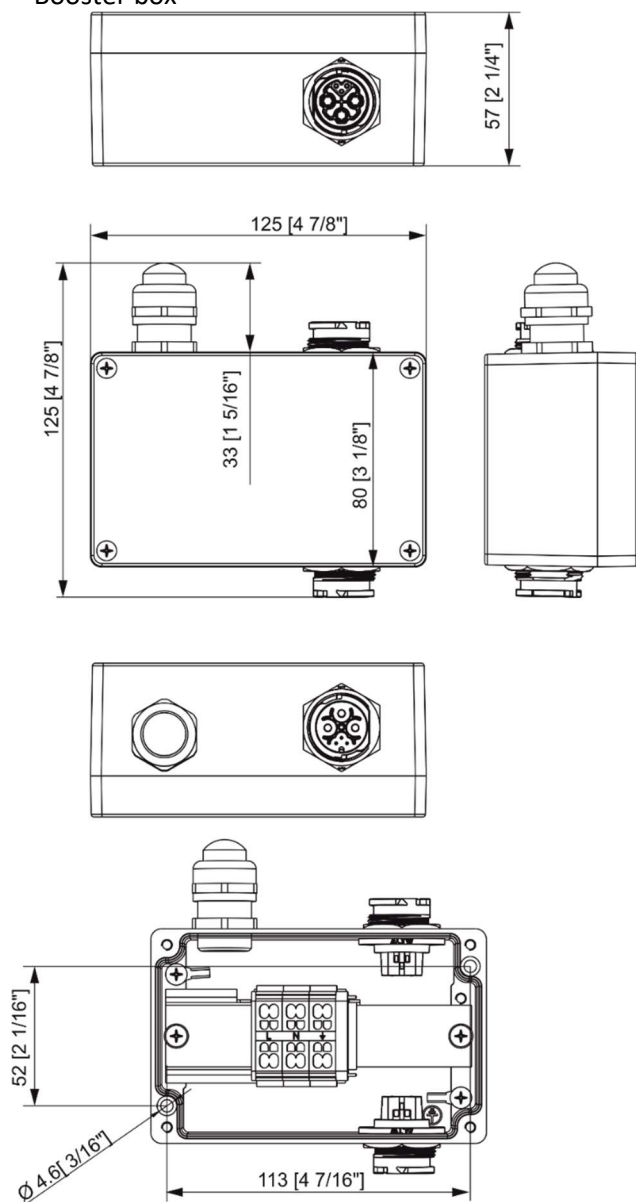

### Included items

- 1 x Eminere Side
- 1 x User manual

### Optional accessories

#### CE Leader Cables FF:

- Leader Cable FF 2m (P/N 13053005)
- Leader Cable FF 5m (P/N 13053006)
- Leader Cable FF 10m (P/N 13053007)
- Leader Cable FF 25m (P/N 13053008)
- Leader Cable FF 50m (P/N 13053009)

#### US Leader Cables FF:

- Leader Cable FF 2m (P/N 13053010)
- Leader Cable FF 5m (P/N 13053011)
- Leader Cable FF 10m (P/N 13053012)
- Leader Cable FF 25m (P/N 13053013)
- Leader Cable FF 50m (P/N 13053014)

Jumper Cables FF/FM:

Jumper Cable FF/FM 0,25m (P/N 13053052)

Jumper Cable FF/FM 0,5m (P/N 13053053)

Jumper Cable FF/FM 1m (P/N 13053054)

Jumper Cable FF/FM 2m (P/N 13053055)

Jumper Cable FF/FM 3m (P/N 13053056)

Jumper Cable FF/FM 5m (P/N 13053057)

Jumper Cable FF/FM 10m (P/N 13053058)

Waterproof Cover Cap FM ZAHB-0006 (P/N 17031173)

Field Installable Connector FF (P/N 13053003)

Field Installable Connector FM (P/N 13053004)

E-boxes:

E-box Daisy (P/N 10063655)

E-box Daisy/W (P/N 10063638)

E-box Lite (P/N 10063657)

E-box Lite/W (P/N 10063653)

E-box Star (P/N 10063656)

E-box Star/W (P/N 10063644)

Booster box (P/N 10063712)

Shield for Eminere 1 RAL9011 (P/N 10980488)

Shield for Eminere 2 RAL9011 (P/N 10980489)

Shield for Eminere 3 RAL9011 (P/N 10980490)

Shield for Eminere 4 RAL9011 (P/N 10980491)

## 5. Cleaning and maintenance

***DANGER !***

***Disconnect from the mains before starting any maintenance or cleaning work***

Rinse off loose dirt with low pressure water spray. Wash the housing with a soft brush or sponge and a mild, non-abrasive washing detergent. Rinse it.

Maintenance and service operations are only to be carried out by a qualified person.

Should you need any spare parts, please use ROBE OEM parts.

### 5.1 Disposing of the product

To preserve the environment please dispose or recycle this product at the end of its life according to the local regulations and codes.

## 6. ChangeLog

This section summarizes changes in the user manual.

Version of the manual	Date of issue	Description of changes
1.1	10/07/2020	Voltage range changed
1.2	23/07/2021	Optional accessories changed
1.3	19/08/2021	Jumper cables changed in Optional accessories
1.4	19/10/2021	Technical specifications changed
1.5	26/11/2021	Optional accessories changed
1.6	20/12/2021	Jumper cable mounting added
1.7	06/01/2022	Jumper cable mounting changed
1.8	23/02/2022	Sealing circle added to jumper cable mounting
1.9	19/05/2022	QR code added

*Specifications are subject to change without notice.*

*May 19, 2022*

*Copyright © 2019-2022 Robe Lighting - All rights reserved*

Made in CZECH REPUBLIC by ROBE LIGHTING s.r.o. Palackeho 416/20 CZ 75701 Valasske Mezirici