



The unit must be installed by a qualified electrician in accordance with all national and local electrical and construction codes and regulations. This device falls under class one and must be grounded!



STEP 1 CABLE GLAND

1A For bottom connection

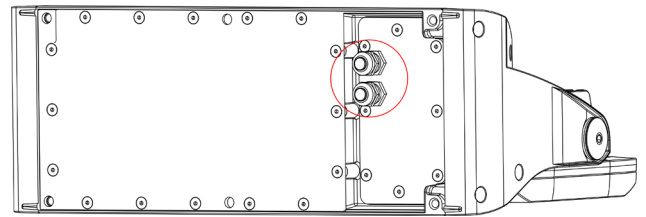
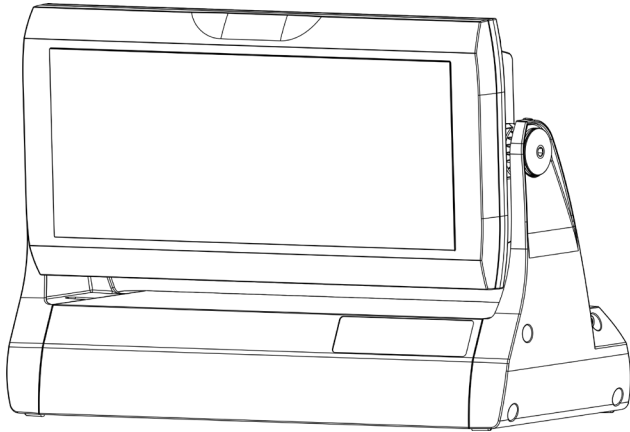

Inlets for power and data from bottom side of the luminaire.

1B For side connection

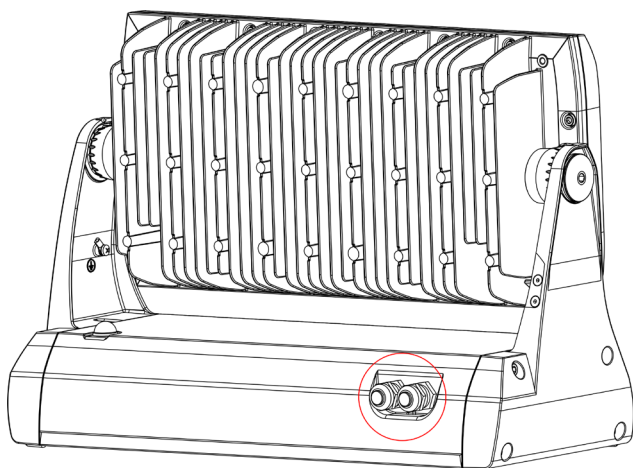

Inlets for power and data from side of the luminaire.

STEP 2 UNCOVER JUNCTION BOX

8X  M5x18

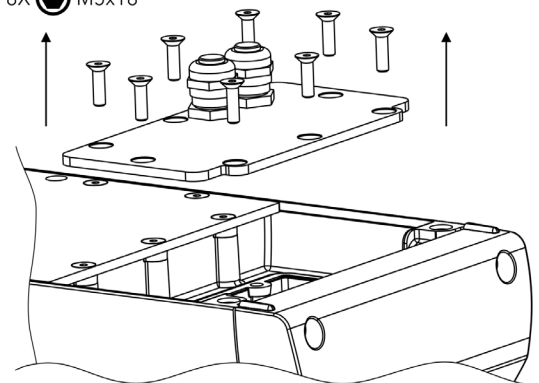

Uncover junction box located on the bottom side of luminaire.

STEP 3 CONNECTION

1 Strip these lengths for cable connections

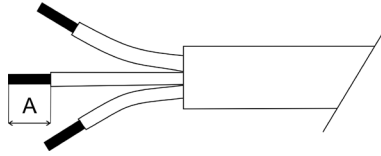

	A
Power Connection	9mm
Data Connection	7mm

2 Connection - colour coding

To connect the Divine 160 to mains and a DMX controller, use a 5-core cable Flamar Li9YC11Y. The 3 colors serve for the power supply and 2 shielded cores are intended for DMX connection.

Power and Data Connection

WIRE	POWER CONNECTION	WIRE	DATA CONNECTION
Brown	L	White	Data - (D-)
Blue	N	Red	Data + (D+)
Yellow/Green	Ground	Shielding	Data Ground (0V)

3A Wiring connection (control menu inside)

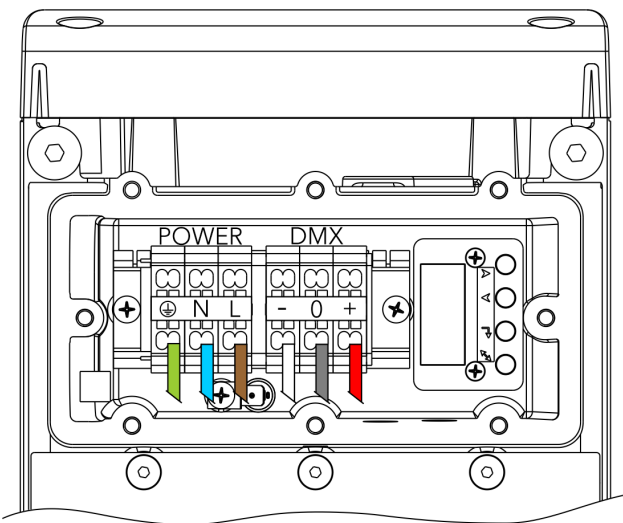

3B Wiring connection (control menu outside)

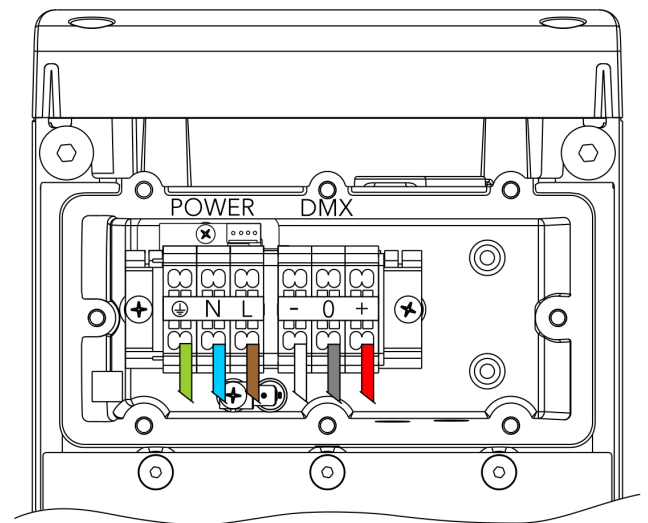

STEP 4 CONTROL MENU

1A Control menu inside

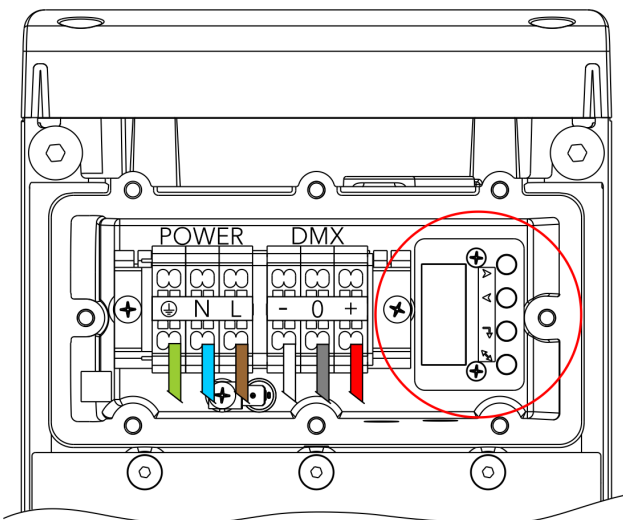

Set control menu inside junction box.

1B Control menu outside

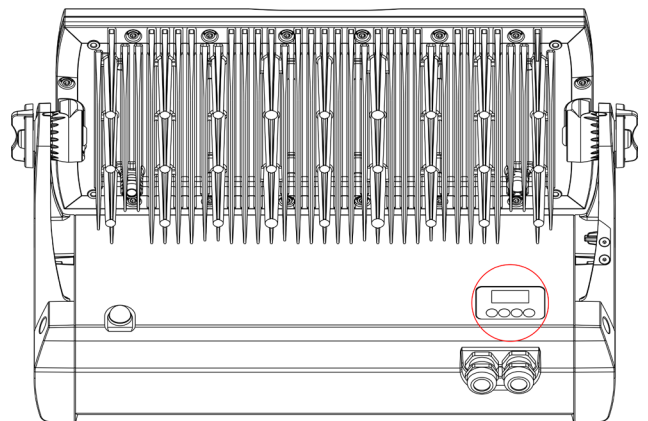

Set control menu.

STEP 5 CLOSE JUNCTION BOX

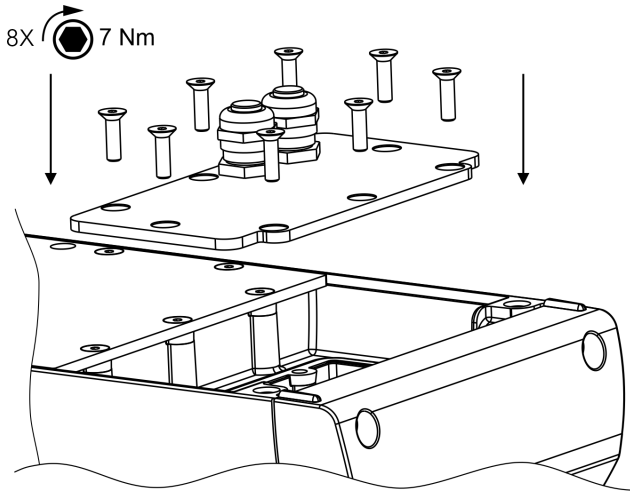

Before applying the torque, make sure the thread is clean and functional.

STEP 6 CABLE GLAND INSTALLATION

Use wrench size 24 for cable gland M20x1.5
Use wrench size 16 for cable gland M12x1.5

Install Cable glands individually!

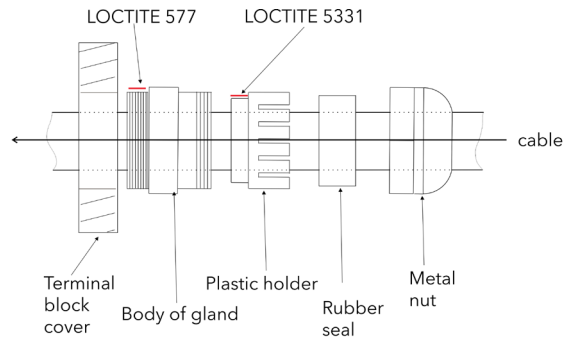

We recommend to apply an adequate layer of the paste LOCTITE 5331 on the plastic holder of the cable gland before inserting in into the body of the gland and an adequate layer of the paste LOCTITE 577 on the thread of the gland body.

Failure to properly install cable glands will result in failure of the water tight seal!

STEP 7.A INSTALLATION WITH SURFACE MOUNT ADAPTOR

1

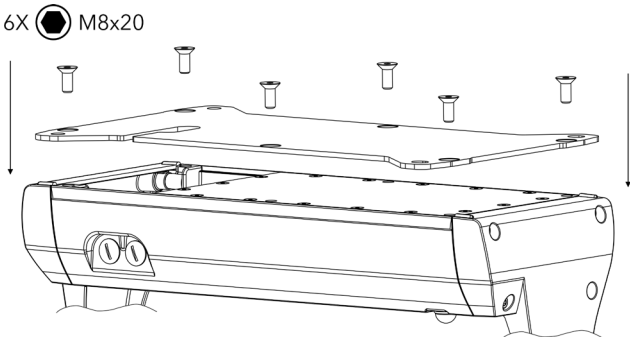

Mount the adaptor using 6 mounting screws.

2

Use fasteners that are appropriate for use with your mounting surface.

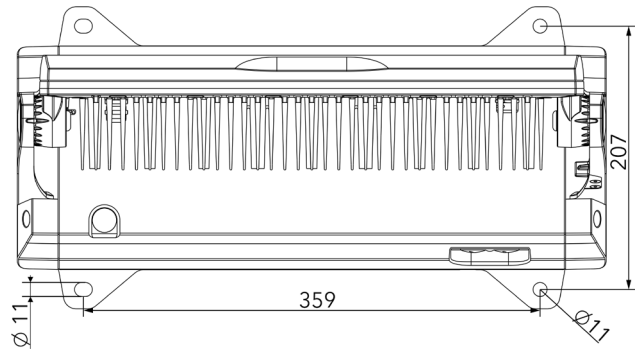

Drill holes to the surface according to holes spacing. Mount Divine via mounting holes on the surface.

STEP 7.B INSTALLATION WITH SET OF RUBBER FEET

4X M8x20

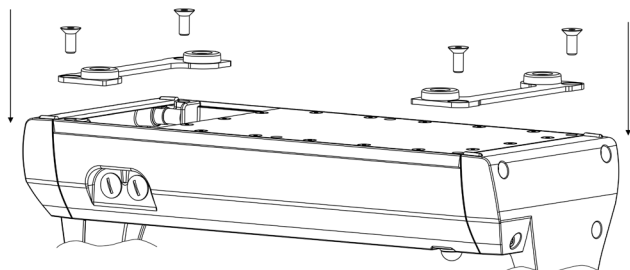

Mount pair of rubber feet using 4 screws.

STEP 7.C INSTALLATION WITH C-CLAMP ADAPTOR

5X M8x25

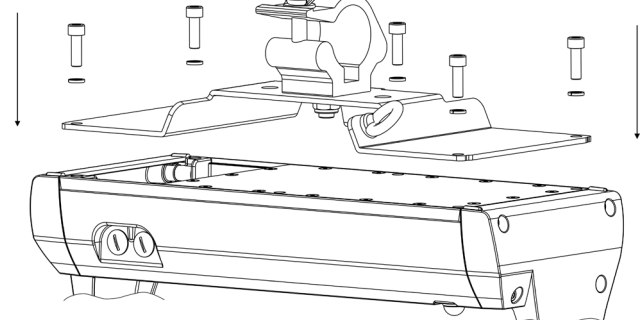

Mount the adaptor using 5 screws.

TYPE OF ACCESSORIES

Optical Demo Set

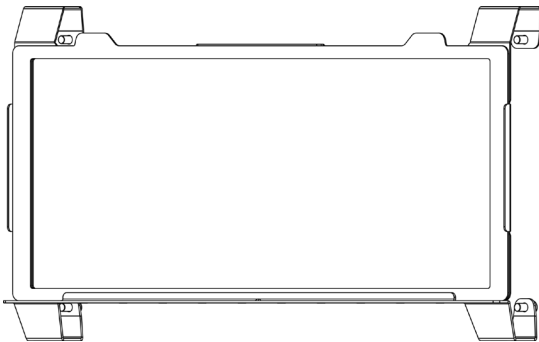

Half Top Hat

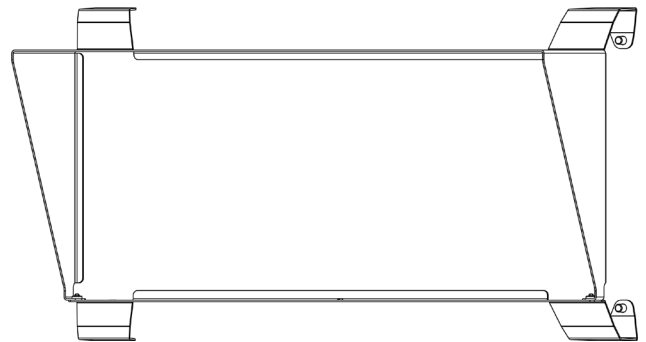

Top Hat

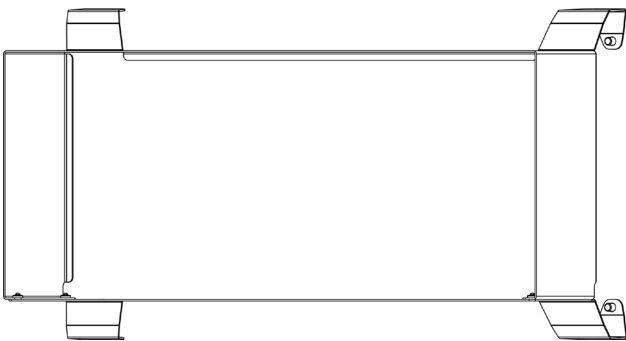

Wire Guard/Anti-Glare

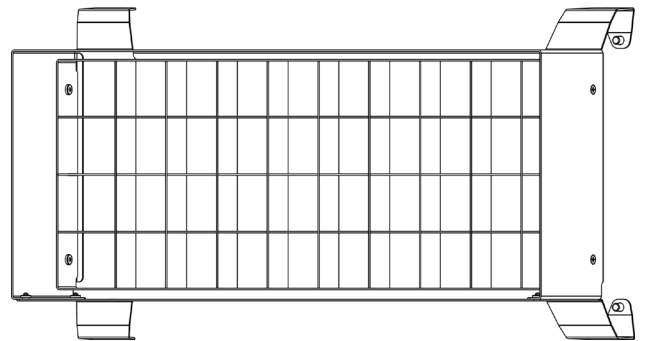

Barndoor Module

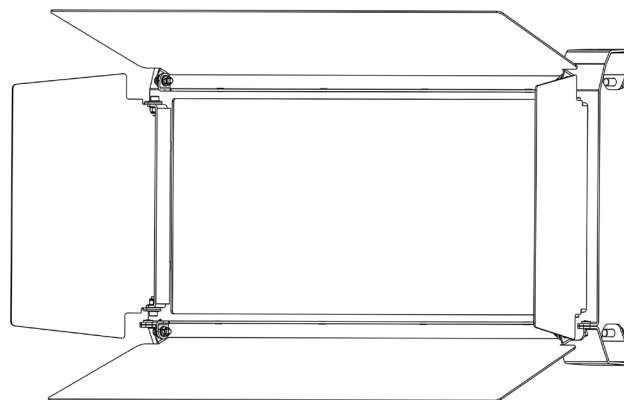

STEP 8 INSTALLATION OF ACCESSORIES

1

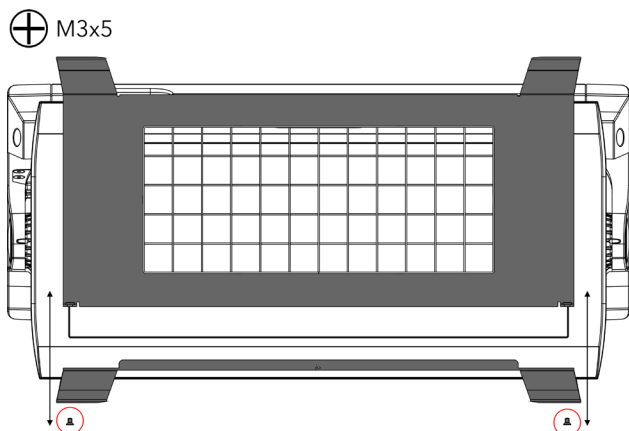

Unscrew two screws and split accessory to two parts. Place each part onto the luminaire's head and screw them together.

2

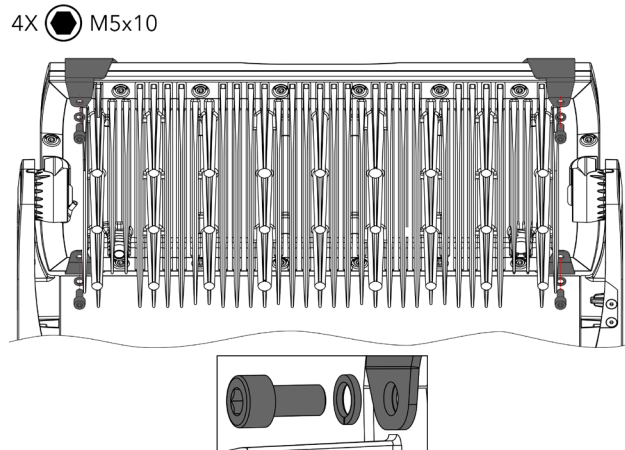

Secure accessory by 4 screws with spring washer at the back side of luminaire's head.

STEP 9 NASTAVENÍ POZICE HLAVY

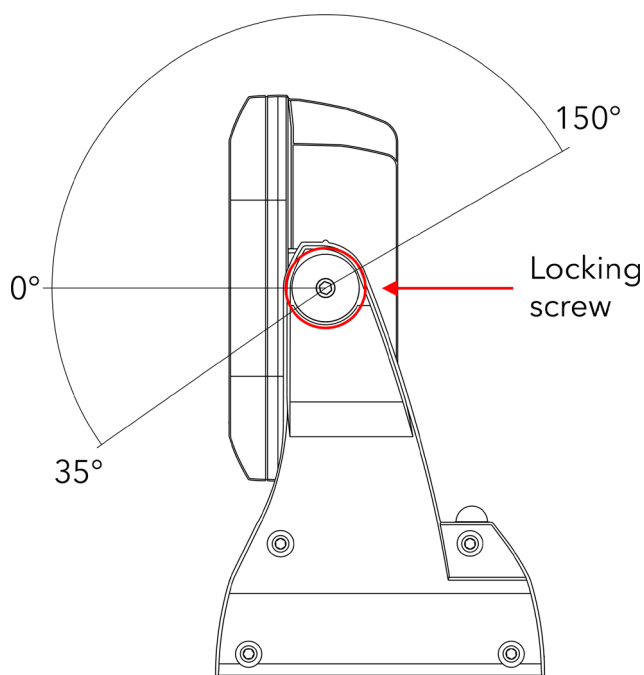

Release locking screw on each sides. Angle fixture to desired position and tighten locking screw on each sides.