

ARC SOURCE™ INGROUND 24MC

INSTALLATION INSTRUCTIONS



The unit must be installed by a qualified electrician in accordance with all applicable regulations including local and national construction and electrical codes. This device falls under class I and must be grounded!



STEP 1 PREPARE SLEEVE AND LUMINAIRE

1

3X M6x25

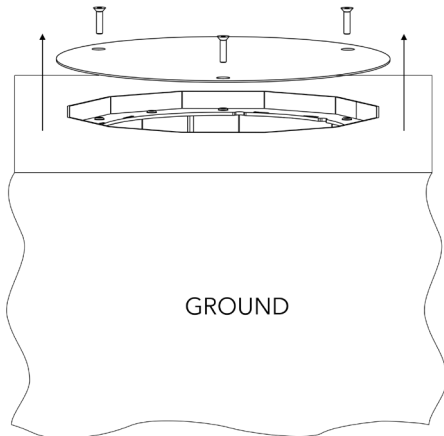

Remove temporary installation sleeve cover plate.

2

6X M5x20

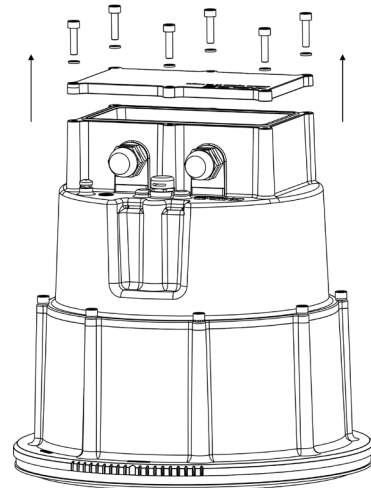

Remove junction box cover.

STEP 2 CONNECTION

1

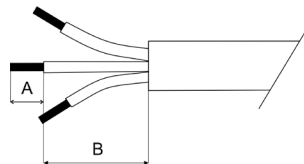

	A	B
Power Connection	7mm	70mm
DMX Connection	7mm	70mm

Strip these lengths for cable connections.

2 Connection - colour coding

DMX Connection

0	-	+
Data Ground	Data -	Data +

Power Connection

	L	N	GROUND
Core (EU)	Brown	Blue	Green/Yellow
Core (US)	Black	White	Green

3 Connection

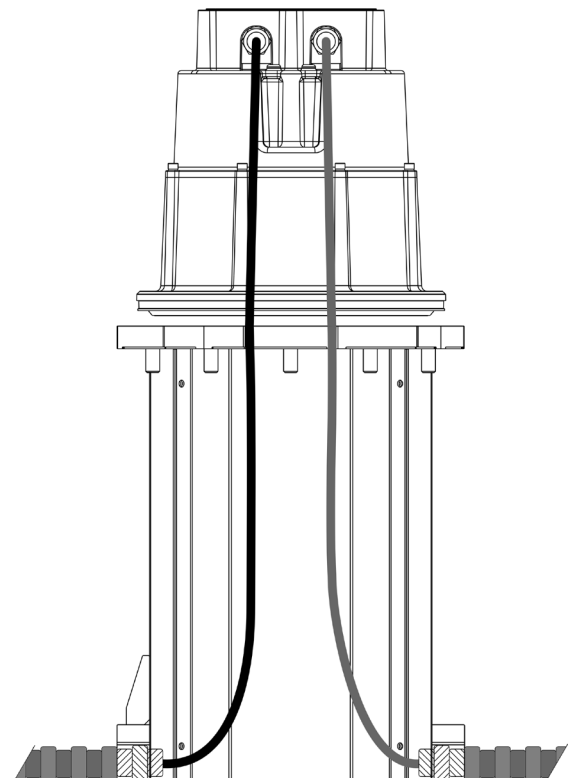

ARC SOURCE™ INGROUND 24MC

INSTALLATION INSTRUCTIONS

4 Wiring connection

Connection with two cables

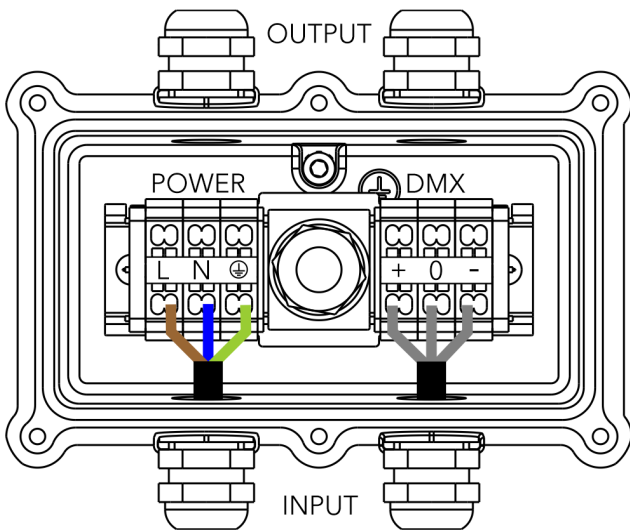

Connection with one cable

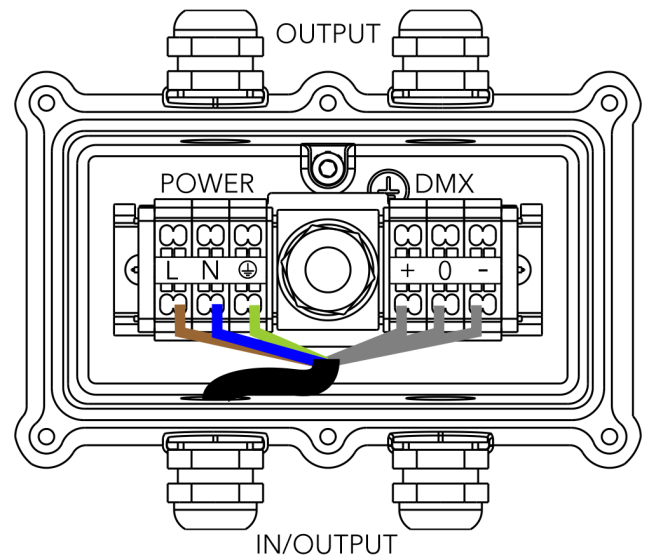

For DMX and Power - EU color code shown

STEP 3 CABLE GLAND INSTALLATION

Put cable thru cable gland M20x1.5 and connect into connection terminal. Assemble cable gland as shown below. Use wrench size 24 for cable gland M20x1.5

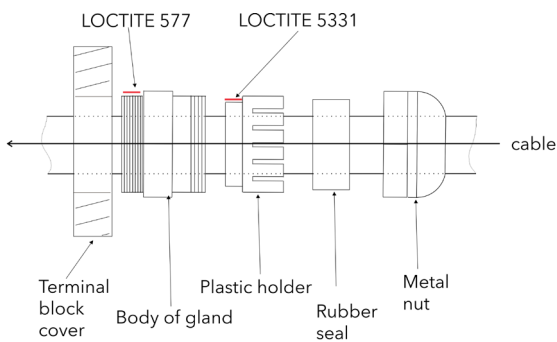

Apply Loctite 5331 thread sealant on the plastic holder and Loctite 577 thread locking compound on the gland body in the indicated locations prior to assembly.

Failure to properly install cable glands will result in failure of the water tight seal!

STEP 4 CLOSE JUNCTION BOX

6X  6 Nm M5x20

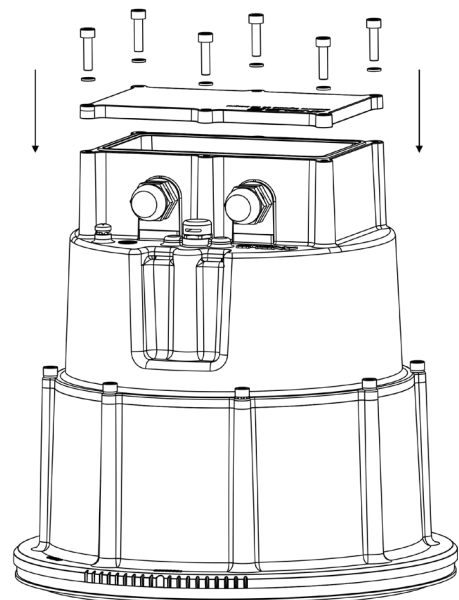

Cover junction box. Before applying the torque, make sure the thread is clean and functional.

ARCOURCE™ INGROUND 24MC

INSTALLATION INSTRUCTIONS

STEP 5 INSTALLATION OF ARCOURCE INGROUND

1

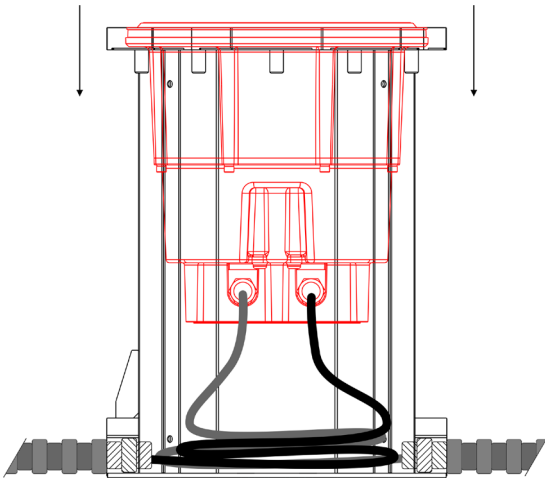

Insert the ArcSource Inground into the installation sleeve and adjust it to desired position.

2

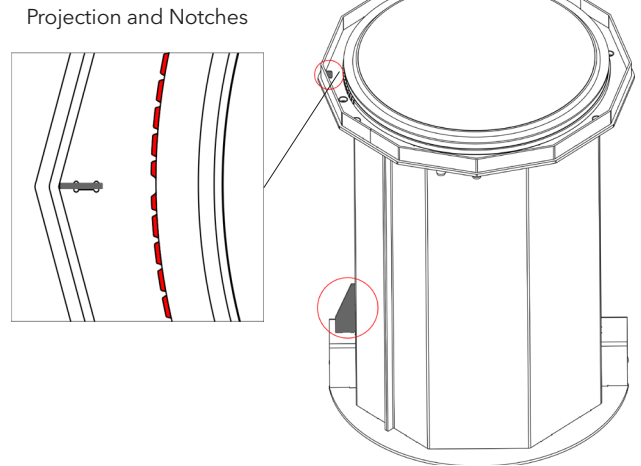

There is a projection and the pad on the sleeve housing and the notches on the ArcSource Inground in order to facilitate adjusting of the ArcSource Inground towards the sleeve. The centre of the notches on the ArcSource Inground also indicates the axis around which the LED module tilts.

3 Instalace chrániček za sebou

Projection and Notches

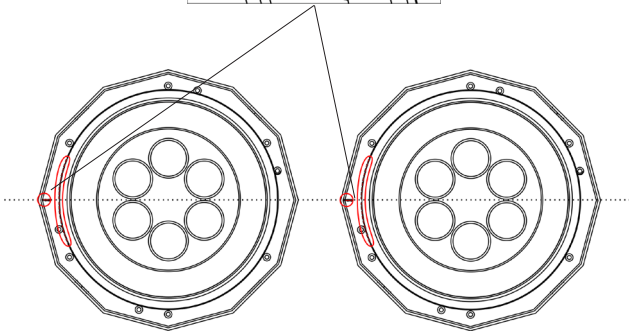
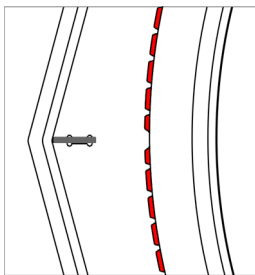

If units are installed in a row, keep the projection on the sleeve housing on the same side at all units to keep the same direction of tilting of LED modules.

4

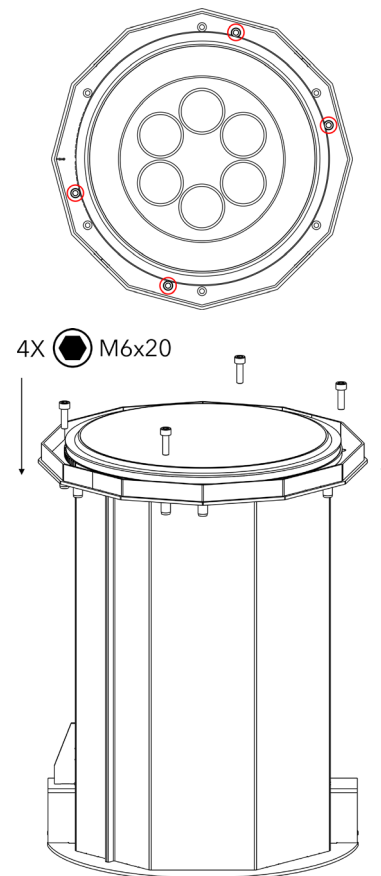

Secure the ArcSource Inground 24 MC Integral in desired position

5

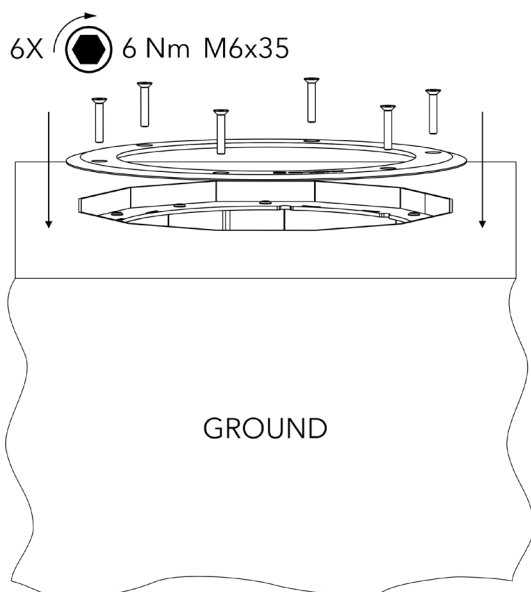

Insert top flange on the ArcSource Inground and screw it on the sleeve. Before applying the torque, make sure the thread is clean and functional.

STEP 6 BEAM TILT ADJUSTMENT

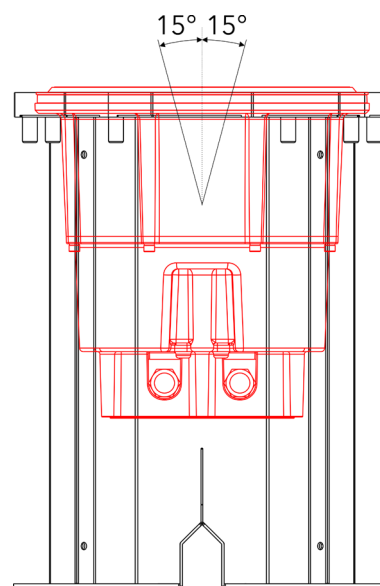

The fixture beam can be tilted $\pm 15^\circ$ from a vertical axis by means of the item "tilt" in the fixture menu. Adjusted position of the LED module is permanent kept, also after disconnected the fixture from mains. During the tilt adjustment, a white beam will appear.