

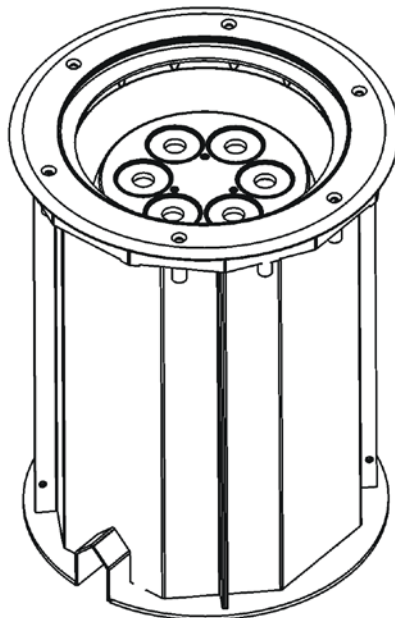

**ArcSource Inground 24 MC Integral
(RGBW, SW, Single colour)**

**ArcSource Inground 24 MC Integral/W
(RGBW, SW, Single colour)**



USER MANUAL

Version 2.1

Table of contents

1. Safety instructions	3
2. Fixture exterior view	4
3. Installation	4
3.1 Mounting	4
3.2 Beam tilt adjustment	8
3.3 Fixture with asymmetric lenses	9
3.4 Setting and control	9
3.5 Wireless DMX operation.....	11
4. ArcSource Inground 24 MC Integral - DMX protocols	14
4.1 RGBW version	14
4.2 SW version	15
4.3 Single colour version.....	16
5. Control menu map.....	17
5.1 RGBW version	17
5.2 SW version	20
5.3 Single colour version.....	22
6. Fixture menu.....	24
6.1 Fixture Address	25
6.2 Fixture information.....	25
6.3 Personality	26
6.4 Manual mode.....	27
6.5 Test sequences	27
6.6 Stand-alone setting.....	27
6.7 Special functions.....	28
7. RDM	29
8. Technical specifications	31
10. Cleaning and maintenance	33

**FOR YOUR OWN SAFETY, PLEASE READ THIS USER MANUAL CAREFULLY
BEFORE POWERING OR INSTALLING YOUR ArcSource Inground 24 MC Integral !
Save it for future reference.**

This device has left our premises in absolutely perfect condition. In order to maintain this condition and to ensure a safe operation, it is absolutely necessary for the user to follow the safety instructions and warning notes written in this manual.

The manufacturer will not accept liability for any resulting damages caused by the non-observance of this manual or any unauthorized modification to the device.

Please consider that damages caused by manual modifications to the device are not subject to warranty.

1. Safety instructions

DANGEROUS VOLTAGE CONSTITUTING A RISK OF ELECTRIC SHOCK IS PRESENT WITHIN THIS UNIT!

Make sure that the available voltage is not higher than stated on the fixture.

This fixture should be operated only from the type of power source indicated on the marking label. If you are not sure of the type of power supplied, consult your authorized distributor or local power company.

Always disconnect the fixture from AC power before removing housing.

Do not install the unit near naked flames.

Refer servicing to qualified service personnel.

This fixture falls under protection class I. Therefore this fixture has to be connected to a mains socket outlet with a protective earthing connection.

Do not connect this fixture to a dimmer pack.

LED light emission. Risk of eye injury.

Do not look straight at the fixture's LEDs during operation. The intense light beam may damage your eyes.

Warning: the fixture's transparent cover becomes hot during operation.

Avoid brute force when installing the fixture.

The fixture was designed for outdoor use. This fixture must not be used for underwater installation.

When choosing the installation spot, please make sure that the fixture is not exposed to extreme heat or dust.

Avoid using the unit in locations subject to possible impacts.

The transparent cover never must be covered with any material.

Only operate the fixture after having checked that the housing is firmly closed and all screws are tightly fastened.

The fixture becomes hot during operation. Allow the fixture to cool approximately 20 minutes prior to manipulate with it.

ArcSource Inground 24 MC Integral

Operate the fixture only after having familiarized with its functions. Do not permit operation by persons not qualified for operating the fixture. Most damages are the result of unprofessional operation!

Please consider that unauthorized modifications on the fixture are forbidden due to safety reasons!

Please use the original packaging if the fixture is to be transported.

Dismantling of the unit, in case of its repair, must be carried out in a place with no rain.

2. Fixture exterior view

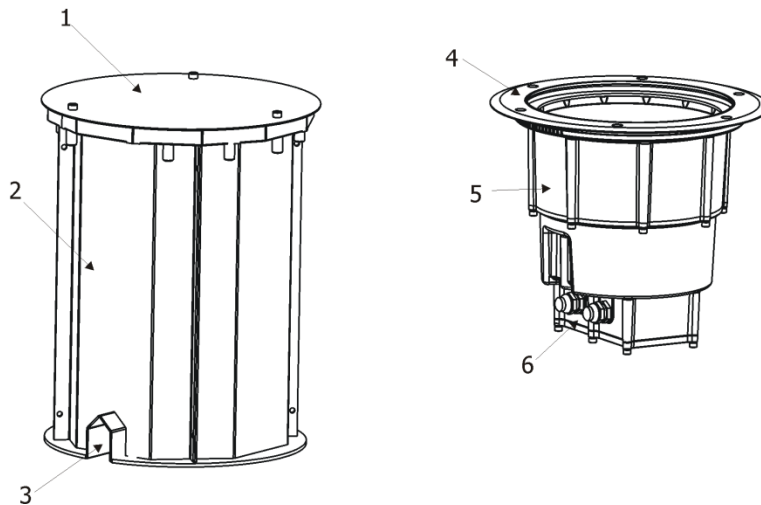

- 1. Temporary cover
- 2. Installation sleeve
- 3. Aperture for cables

- 4. Flange on glass cover
- 5. Body of the ArcSource Inground 24 MC Integral
- 6. Junction box

3. Installation

3.1 Mounting

***The unit must be installed by a qualified electrician in accordance with all national and local electrical and construction codes and regulations.
With respect to the purpose of using the unit, the residual current circuit breaker is highly recommended.***

The ArcSource Inground 24 MC is controlled via DMX 512 serial digital signal. It is indispensable to use cables that meet EIA RS-485 specifications to connect the fixture to the control console.

Warning!
If the ArcSource Inground 24 MC Integral will be exposed max. allowed static load, the subsoil of the installation sleeve has to withstand load of 35kN.

ArcSource Inground 24 MC Integral

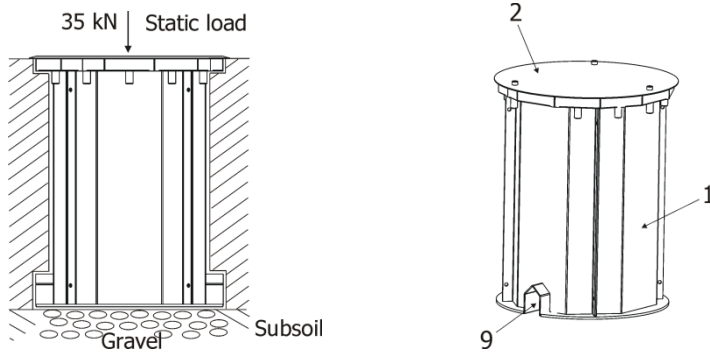

1. Prepare an adequate hole with a good drainage leaving 300 mm of gravel on the bottom, insert the installation sleeve (1) into the hole and unscrew the temporary cover (2) from the installation sleeve. Prepare cabling for the unit. The length of supply (DMX) cables in the installation sleeve has to allow to pull the ArcSource Inground 24 MC Integral out from the installation sleeve and turn it upside down to get access to the junction box.

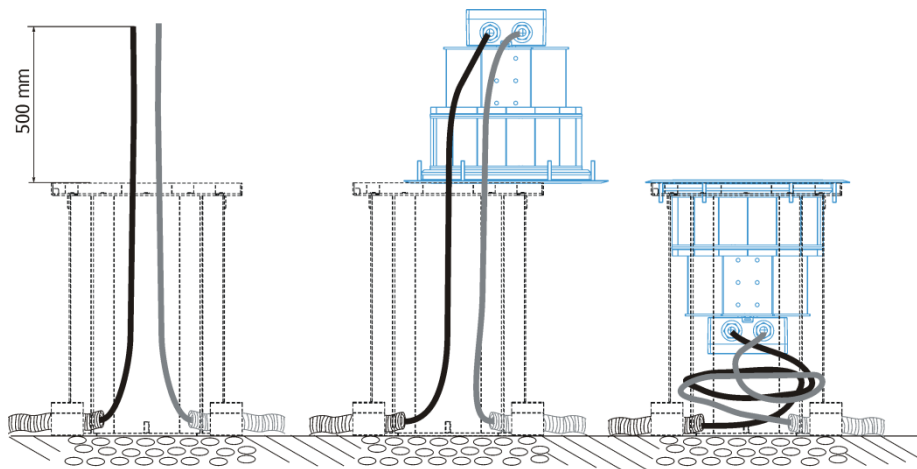

2. Connect the power cable and DMX cable to the junction box (3) of the ArcSource Inground 24 MC Integral (4). The apertures (9) serve for passing of cables.

Power connection

	L	N	⏚
EU	Braun	Blue	Green/yellow
US	Black	White	Green

This device falls under class one and must be grounded!

DMX connection

+	0	-
Data +	Data ground(shielding)	Data -

Base technical features of the ABB terminal blocks:

Type: DS 2,5/10.4L (4 springs mini blocks)

Parameter	IEC	UL/CSA
Rated voltage	800 V	600 V
Rated current	24 A	15 A
Wire size rated/gauge	2.5mm ² /A2	12AWG
Wire stripping length	9.5 mm	

Remove end caps from cable glands before passing cables into the junction box. The four cable glands M20 with standard seals serve for cable of diameter of 6-12mm, for smaller diameter of cable (4-8mm), you have to remove

ArcSource Inground 24 MC Integral

original sealing from the cable gland M20 and use the enclosed reducing seal instead it. Four reducing seals for diameter of cable 4-8mm (P/N 13051388) are enclosed.

Fully tighten cable gland nuts and check that cables are properly fastened in the cable glands.

Note: To keep declared IP rating, every cable gland has to be covered with the end cap if this cable gland is not used for cable passing.

Cable gland M20 MS (P/N 13051206)

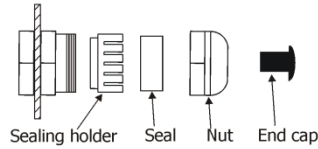

4 x Standard seal - part of cable gland M20 MS
(for diameter of cable: 6-12mm)

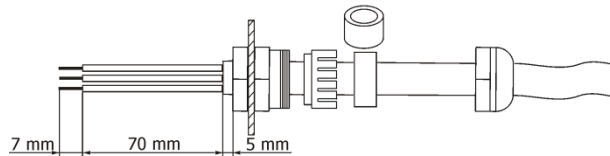

4 x Reducing seal (P/N 13051388) - enclosed, standard seal
has to be removed before installing this seal
(for diameter of cable: 4-8mm)

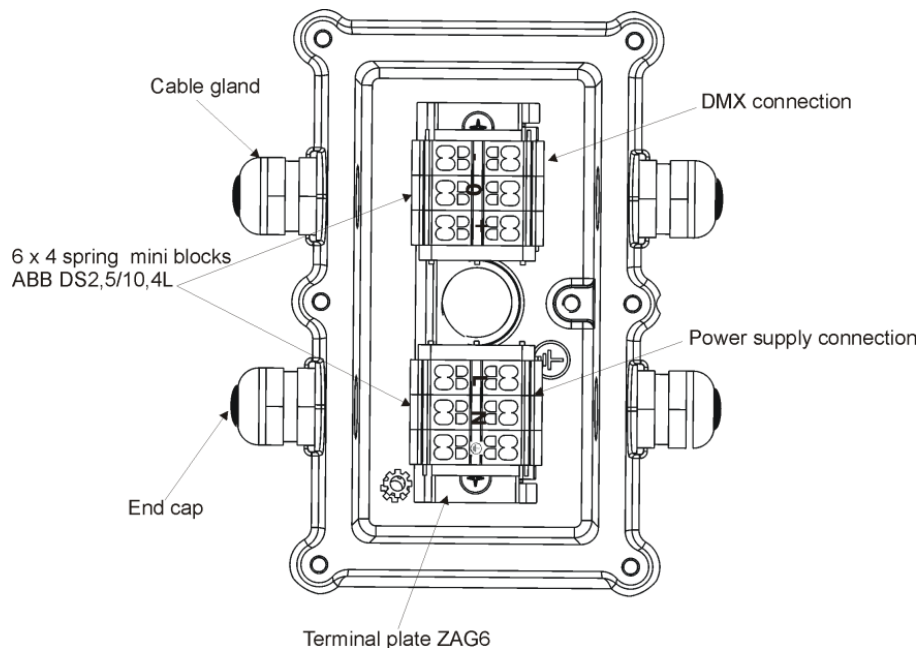
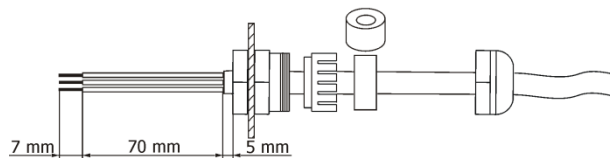

After connection needed cables, screw the cover of the junction box with four bolts using a tightening torque of 8Nm. Check that all cable glands and bolts are firmly screwed.

3. Insert the ArcSource Inground 24 MC Integral (4) into the installation sleeve (1) and adjust it to desired position.

Note: There is a projection (A) and the pad (D) on the sleeve housing and the notches (C) on the ArcSource Inground 24 MC Integral in order to facilitate adjusting of the ArcSource Inground 24 MC Integral towards the

ArcSource Inground 24 MC Integral

sleeve. The centre of the notches (C) on the ArcSource Inground 24 MC Integral also indicates the axis around which the LED module tilts.

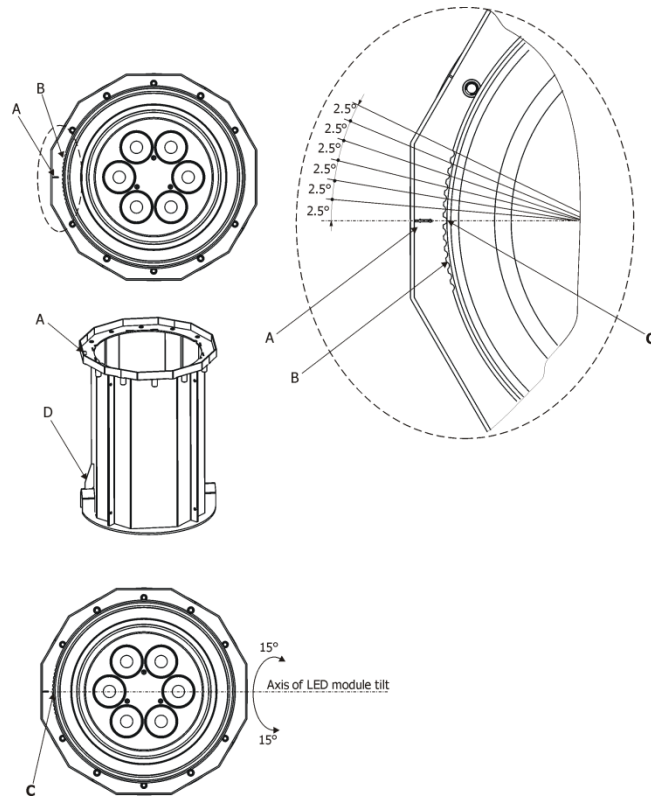

If units are installed in a row, keep the projection (A) on the sleeve housing on the same side at all units to keep the same direction of tilting of LED modules.

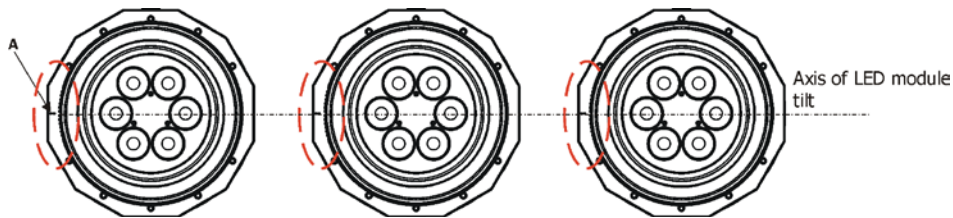

4. Secure the ArcSource Inground 24 MC Integral in desired position by means of the four Allen bolts M6x20mm (5).

5. Insert top flange (6) on the ArcSource Inground 24 MC Integral and screw it on the sleeve (1) by means of the six screws M6x30mm (7). The screws must be tightened securely and uniformly, tightening first one and then the one diametrically opposite to it.

After connecting the ArcSource Inground 24 MC Integral to mains, set desired tilt of the LED module.

ArcSource Inground 24 MC Integral

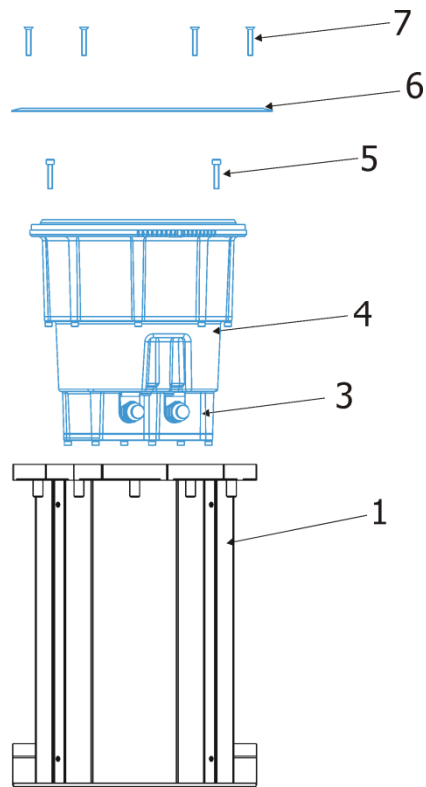

3.2 Beam tilt adjustment

The fixture beam can be tilted $\pm 15^\circ$ from a vertical axis by means of the item "tilt" in the fixture menu (SPEC \rightarrow tilt). Adjusted position of the LED module is permanent kept, also after disconnected the fixture from mains. During the tilt adjustment, a white beam will appear.

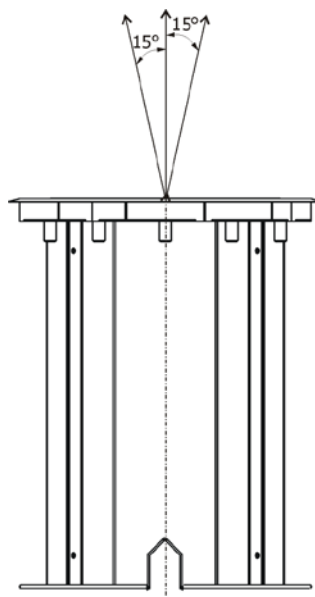

3.3 Fixture with asymmetric lenses

Differentiation of fixtures with asymmetric lenses and shape of light output.

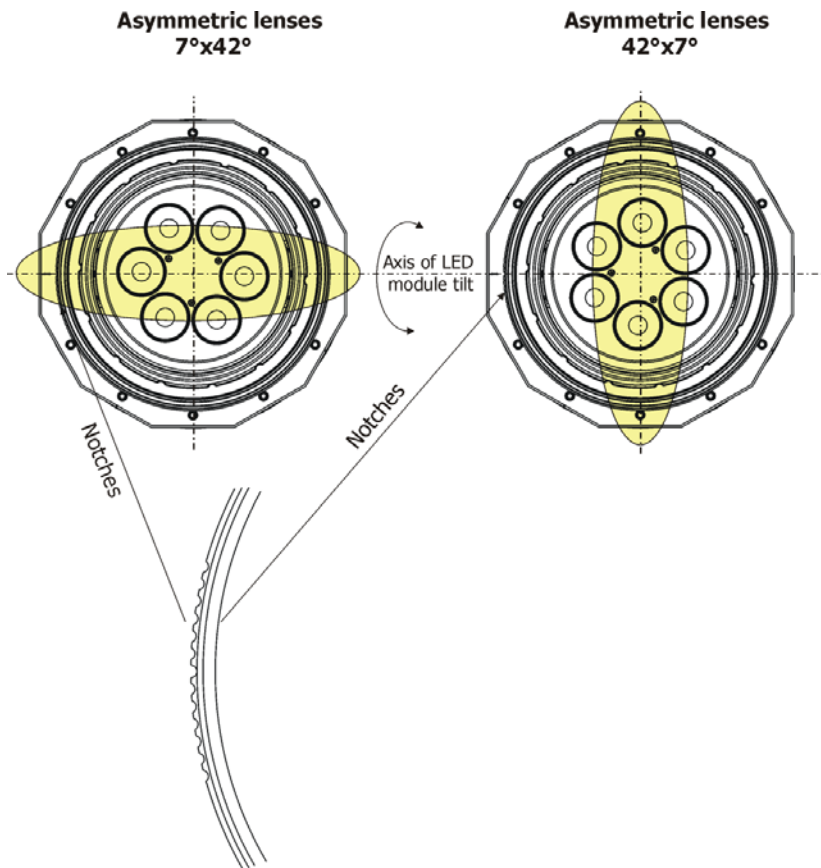

3.4 Setting and control

For setting DMX address, selecting DMX mode and for another settings you need either Robe Universal Interface WTX or the RDM Communicator. Please see the Robe Universal Interface WTX or RDM Communicator user manuals to get more information about this products.

1. Robe Universal Interface WTX

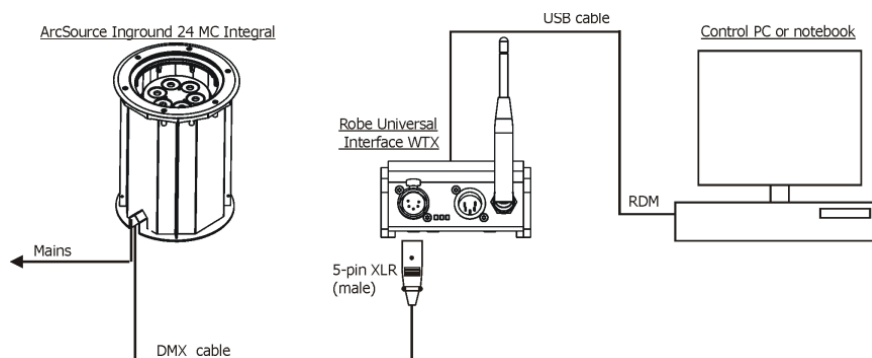

Note: the Robe Universal Interface WTX can be also used for wireless control of the wireless DMX version of the ArcSource Inground 24 MC Integral.

ArcSource Inground 24 MC Integral

2. RDM Communicator

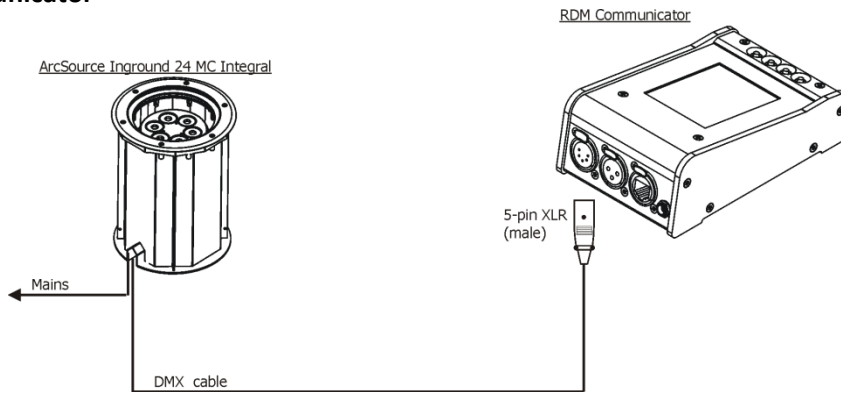

Note: the RDM Communicator cannot be used for wireless control of the wireless DMX version of the ArcSource Inground 24 MC Integral.

3.5 Wireless DMX operation

The wireless version of the ArcSource Inground 24 MC Integral is equipped with the Lumen Radio CRMX module and antenna for receiving DMX signal. CRMX module operates on the 2.4 GHz band.

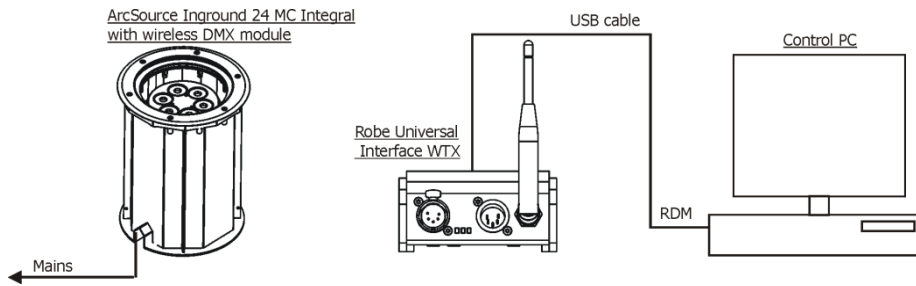

Setting of the ArcSource Inground 24 MC Integral with CRMX module.

We recommend to use the Robe Universal Interface WTX for setting and readout values in the fixture.

A RDM-network software has to be installed on your computer.

Run RDM-network on your computer and click with the right button of the mouse on the fixture UID and select the **Remote LED display** option from the menu list as shown below.

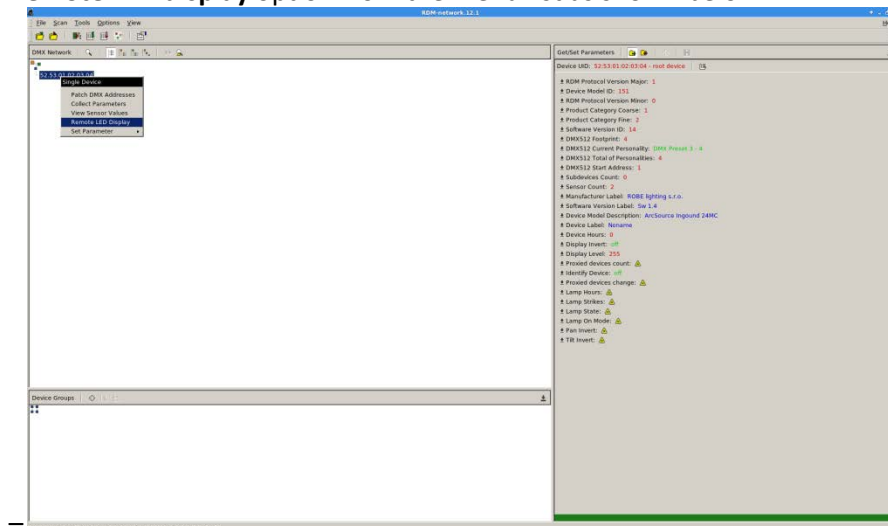

The Remote LED Display window will appear. Now you can control the fixture using the **UP, Down, Enter, Escape** and **Reset** buttons.

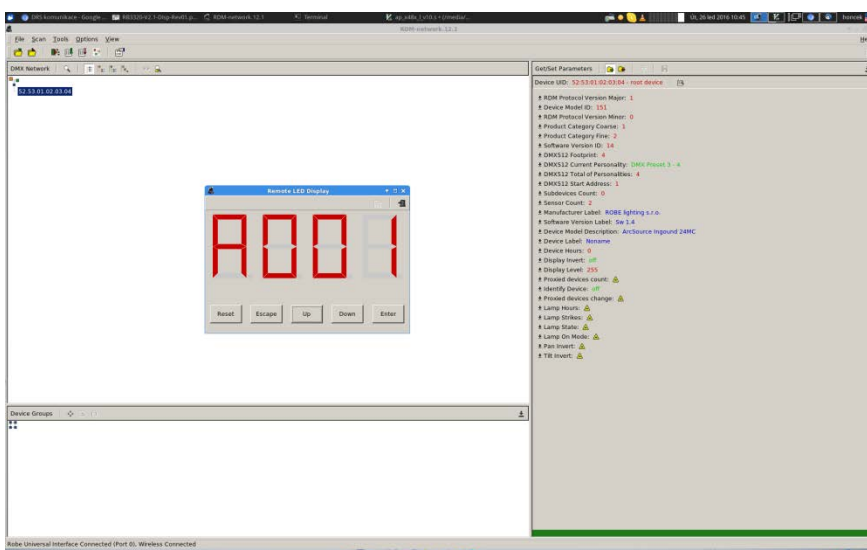

After switching the fixture on, the fixture waits for DMX signal on “wire” input for 30 sec. If no DMX signal is present, fixture starts switching between “wire” and “wireless” DMX input until finds DMX signal on some input. During this process fixture’s effects (channels) stay in positions set in the menu Init Positions (In.Po). If DMX signal is located on both inputs (wired, wireless) at the same time, the signal which was receiving as last will be chosen.

To link the fixture with DMX transmitter.

The fixture can be only linked with the transmitter by running the link procedure at DMX transmitter . After linking , the level of DMX signal (0-100 %) is displayed in the menu item “**SiGn.**” (SPEC-->rAdl.--> SiGn.)

To unlink the fixture from DMX transmitter.

The fixture can be unlinked directly from the transmitter via the menu item “ **unLi.**” (SPEC-->rAdl.--> unLi.). The menu item “**rAd.t.**” (PErS-->rAd.t) allows to set time after the linked fixture will be unlinked from the transmitter, if the transmitter does not transmit DMX signal. This time can be set from 0.1 hr (6 minutes) to 25.5 hours, default value is 1 hour. Value Off means 168 hrs.

Another method to unlink the fixture is by means of a magnetic chip applied to the magnetic sensor located under the front glass cover of the fixture. The magnetic chip has to be placed on the mark  on the glass cover for 5-10 seconds. Successful unlinking is indicated by the signal LED (red), lighting up for 5 seconds. After this, the signal LED will flash in accordance to the **LEd.E. - Error signalling** menu of Section 6.3.

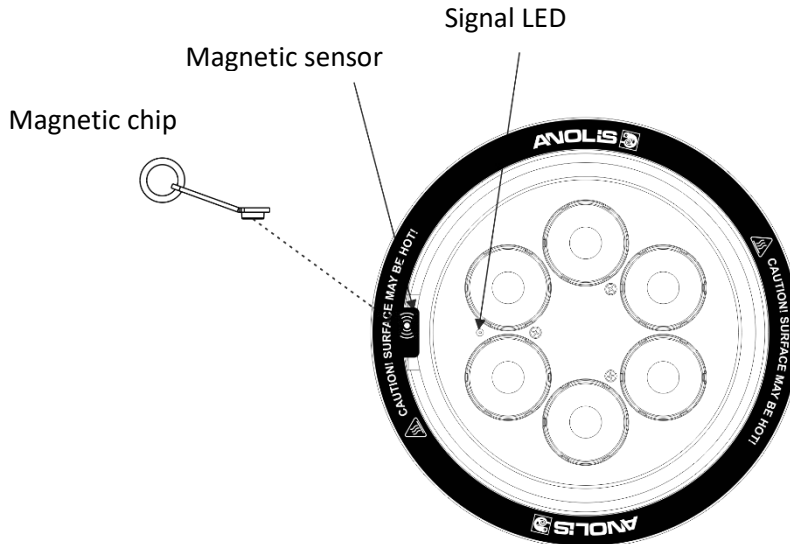

ArcSource Inground 24 MC Integral

Direct visibility between a transmitter and the ArcSource Inground 24 MC Integral must be ensured without no obstacles (buildings, trees, cars....).

The minimum angle between the ground with the ArcSource unit and transmitter's antenna is 10°.

Distance between a DMX transmitter and the ArcSource unit depends on transmission range of used DMX transmitter, surrounds etc (we recommend to test behaviour of DMX transmitter with the ArcSource Inground 24 MC Integral before installation). The Robe Universal Interface WTX has been tested 80m from the ArcSource Inground 24 MC Integral at open space.

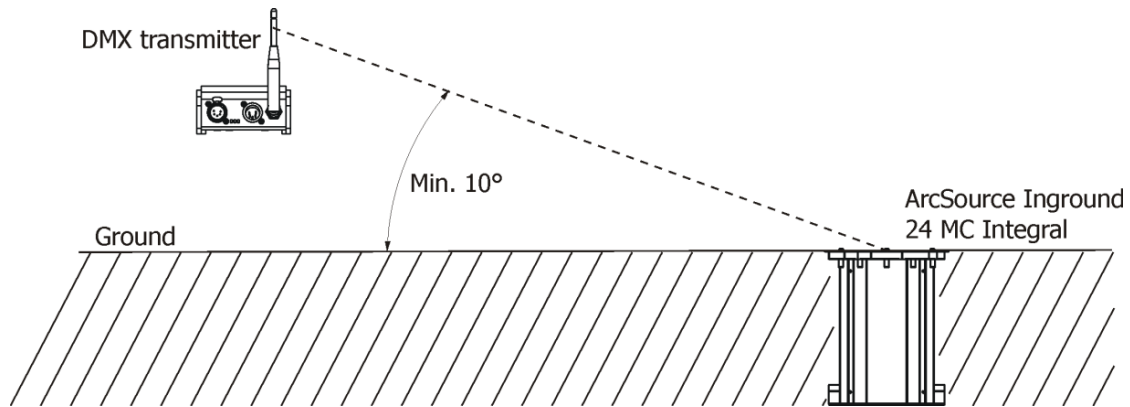

Note: The ArcSource Inground 24 MC Integral sends received wireless DMX signal to its wired DMX output. The fixture behaves as a "Wireless/Wired" adaptor.

E.g. You have 5 fixtures, one fixture is equipped with the wireless DMX module and 4 fixtures are standard fixtures without wireless DMX module. The first fixture receives wireless DMX and sends this signal to the rest of fixtures, which are connected to the first fixture by means of the DMX cable in a DMX chain.

4. ArcSource Inground 24 MC Integral - DMX protocols

4.1 RGBW version

Version 1.0 Default mode: 3

Mode/Channel				Value	Function	Type of control
1	2	3	4			
-	1	1	1	0 - 255	Red LEDs Red LEDs saturation control (0-100%)	proportional
-	2	2	2	0 - 255	Green LEDs Green LEDs saturation control (0-100%)	proportional
-	3	3	3	0 - 255	Blue LEDs Blue LEDs saturation control (0-100%)	proportional
-	-	4	4	0 - 255	White LEDs White LEDs saturation control (0-100%)	proportional
-	-	-	5	0 1-255	CTO No function Colour temperature correction (0-100%)	proportional
1	-	-	6	0 1-2 3 4-5 6 7-9 10-12 13-15 16 17-55 56 57 - 95 96 97 - 134 135 136 - 174 175 176 - 214 215 216 - 246 247 248-251 252-255	Virtual colour wheel No function (for DMX mode 4) White (R+G+B+W=full for DMX mode 1) White 2700 K White 2700 K (Halogen lamp mode) White 3200 K White 3200 K (Halogen lamp mode) White 4200 K White 5600 K White 8000 K Blue (Blue=full, Red+Green+White=0) Red=0, Green→up, Blue =full, White=0 Light Blue (Red=0, Green=full, Blue =full, White=0) Red=0, Green=full, Blue→down, White=0 Green (Red=0, Green=full, Blue =0, White=0) Red→up, Green=full, Blue=0, White=0 Yellow-green (Red=full, Green=full, Blue=0, White=0) Red=full, Green→down, Blue=0, White=0 Red (Red=full, Green=0, Blue=0, White=0) Red=full, Green=0, Blue→up, White=0 Magenta (Red=full, Green=0, Blue=full, White=0) Red→down, Green=0, Blue=full, White=0 Blue (Red=0, Green=0, Blue=full, White=0) Rainbow effect with fade time (fast →slow) Rainbow effect without fade time (fast →slow)	step step step step step step step step step proportional step proportional step step proportional step proportional step proportional step proportional proportional
-	-	-	7	0-31 32-63 64-95 96-127 128-143	Shutter/ Strobe Shutter closed Shutter open Strobe-effect from slow to fast Shutter open Opening pulses in sequences slow--> fast	step step proportional step proportional

ArcSource Inground 24 MC Integral

				144-159 160-191 192-223 224-255	Closing pulses in sequences fast --> slow Shutter open Random strobe-effects from slow to fast Shutter open	proportional step proportional step
2	-	-	8	0 - 255	<u>Dimmer</u> Dimmer intensity from 0% to 100%	proportional
-	-	-	9	0 - 255	<u>Dimmer fine</u> Fine dimmer intensity from low to high	Proportional

4.2 SW version

Version 1.0 Default mode: 1

Mode/Channel			Value	Function	Type of control
1	2	3			
1	-	1	0 - 255	<u>Warm white LEDs</u> Warm white LEDs saturation control (0-100%)	proportional
2	-	2	0 - 255	<u>Cool white LEDs</u> Cool white LEDs saturation control (0-100%)	proportional
-	1	3	0 1-2 3-4 5-6 7-8 9-10 11-12 13-14 15-16 17-247 248 249 250-255	<u>Colour wheel</u> No function White 2800 K White 3200 K White 3800 K White 4200 K White 4600 K White 5000 K White 5600 K White 6300 K Warm white --> Cool white Rainbow effect (with fade time) Rainbow effect Reserved	step step step step step step Step step proportional step step
-	-	4	0-31 32-63 64-95 96-127 128-143 144-159 160-191 192-223 224-255	<u>Strobe</u> Shutter closed Shutter open Strobe-effect from slow to fast Shutter open Opening pulses in sequences slow--> fast Closing pulses in sequences fast --> slow Shutter open Random strobe-effects from slow to fast Shutter open	step step proportional step proportional proportional step proportional step
-	2	5	0 - 255	<u>Dimmer</u> Dimmer intensity from 0% to 100%	proportional
-	-	6	0 - 255	<u>Dimmer fine</u> Fine dimmer intensity from low to high	proportional

4.3 Single colour version

Version 1.0 Default mode: 1

Mode/Channel		Value	Function	Type of control
1	2			
-	1	0-31 32-63 64-95 96-127 128-143 144-159 160-191 192-223 224-255	<u>Strobe</u> Shutter closed Shutter open Strobe-effect from slow to fast Shutter open Opening pulses in sequences slow--> fast Closing pulses in sequences fast --> slow Shutter open Random strobe-effects from slow to fast Shutter open	step step proportional step proportional proportional step proportional step
1	2	0 - 255	<u>Dimmer</u> Dimmer intensity from 0% to 100%	proportional
-	3	0 - 255	<u>Dimmer fine</u> Fine dimmer intensity from low to high	proportional

5. Control menu map

5.1 RGBW version

Default settings=Bold print

Menu Level 1	Menu Level 2	Menu Level 3	Menu Level 4	Menu Level 5	Menu Level 6
A001	dM.Ad.	001-512			
InFo	Poti.	totL			
		rSEt			
	DM.In.	rEd	0-255		
		:			
		F.dim	0-255		
	tEMP.	Cur.t.	tEM.b.		
		Hi.tE.	tEM.L.		
		rSEt			
	VErS.	IC1			
		IC2			
PErS	dM.Pr.	Mod.1			
		Mod.2			
		Mod.3			
		Mod.4			
	rAd.t.	OFF, 0.1..1..25.5hrs			
	M. F.ti	0.1-25.5			
	rGb.C.	On, Off			
	tEM.U.	°C, °F			
	Led.E	On, OFF			
	In.Po.	rEd1	0-255		
		:			
		F.dim	0-255		
		Stor.			

ArcSource Inground 24 MC Integral

Menu Level 1	Menu Level 2	Menu Level 3	Menu Level 4	Menu Level 5	Menu Level 6
	dFSE				
MAn.M.	rEd	0-255			
	:				
	F.din	0-255			
tEst	run				
St.AL.	Auto	Off			
		tEst			
		PrG.1			
		:			
		PrG.3			
	PLAY	tEst			
		PrG.1			
		:			
		PrG.3			
	Edit	PrG.1	St.01	P.End	1-40
		:	:	rEd	0-255
		PrG.3	St.68	:	:
				F.din	0-255
				F.tin.	0-25,5 sec
				S.tin.	0-25.5 sec
				CoPY	
SPEC.	rdML				
	rdMH				
	t.LEd	rGbU			
		Sl.Co.			
		SM.Uh.			
	rAdl	SiGn.			
		unLi			
	l.bLi.	On, OFF			

ArcSource Inground 24 MC Integral

Menu Level 1	Menu Level 2	Menu Level 3	Menu Level 4	Menu Level 5	Menu Level 6
	HOLd	On, Off			
	F.FrE	On, OFF			
	tilt				
	Adj.	Man.M.	rEd		
			:		
			F.din		
		CaL.C.	rEd. C.	0-255	
			GrE.C.	0-255	
			bLu.C.	0-255	
			Uhl.C.	0-255	
			SAUE		
		CAL.t.	2700	rEd.C.	0-255
			3200	GrE.C.	0-255
			4200	bLu.C.	0-255
			5600	Uhl.C.	0-255
			8000		
	uPd.				

5.2 SW version**Default settings=Bold print**

Menu Level 1	Menu Level 2	Menu Level 3	Menu Level 4	Menu Level 5	Menu Level 6
A001	dM.Ad.	001-512			
InFo	Poti.	totL			
		rSEt			
	DM.In.	rEd	0-255		
		:			
		F.dim	0-255		
	tEMP.	Cur.t.	tEM.b.		
		Hi.tE.	tEM.L.		
		rSEt			
	VErS.	IC1			
		IC2			
PErS	dM.Pr.	Mod.1			
		Mod.2			
		Mod.3			
	rAd.t.	OFF, 0.1..1..25.5hrs			
	M. F.Time	0.1-25.5			
	tEM.U.	°C, °F			
	LEd.E	On, OFF			
	In.Po.	UU	0-255		
		:			
		F.dim	0-255		
		Stor.			
	dFSE				
MAn.M.	UU	0-255			
	:				
	F.din	0-255			
tESt	run				

ArcSource Inground 24 MC Integral

Menu Level 1	Menu Level 2	Menu Level 3	Menu Level 4	Menu Level 5	Menu Level 6
St.AL.	Auto	Off			
		tESt			
		PrG.1			
		:			
		PrG.3			
	PLAY	tESt			
		PrG.1			
		:			
		PrG.3			
	Edit	PrG.1	St.01	P.End	1-40
		:	:	UU	0-255
		PrG.3	St.68	:	:
				F.din	0-255
				F.tin.	0-25,5 sec
				S.tin.	0-25.5 sec
				CoPY	
SPEC.	rdML				
	rdMH				
	t.LEd	rGbU			
		Sl.Co.			
		SM.Uh.			
	rAdl	SiGn.			
		unLi			
	l.bLi.	On, OFF			
	HOLd	On, Off			
	F.FrE	On,OFF			
	tilt				
	uPd.				

5.3 Single colour version

Default settings=**Bold print**

Menu Level 1	Menu Level 2	Menu Level 3	Menu Level 4	Menu Level 5	Menu Level 6
A001	dM.Ad.	001-512			
InFo	Poti.	totL			
		rSEt			
	DM.In.	Stro	0-255		
		:			
		F.din	0-255		
	tEMP.	Cur.t.	tEM.b.		
		Hi.tE.	tEM.L.		
		rSEt			
	VErS.	IC1			
		IC2			
PErS	dM.Pr.	Mod.1			
		Mod.2			
	rAd.t.	OFF, 0.1..1..25.5hrs			
	M. F.Time	0.1-25.5			
	tEM.U.	°C, °F			
	LEd.E	On, OFF			
	In.Po.	Stro	0-255		
		:			
		F.dim	0-255		
		Stor.			
	dFSE				
MAn.M.	Stro	0-255			
	:				
	F.din	0-255			

ArcSource Inground 24 MC Integral

Menu Level 1	Menu Level 2	Menu Level 3	Menu Level 4	Menu Level 5	Menu Level 6
tEst	run				
St.AL.	Auto	Off			
		tEst			
		PrG.1			
		:			
		PrG.3			
	PLAY	tEst			
		PrG.1			
		:			
		PrG.3			
	Edit	PrG.1	St.01	P.End	1-40
		:	:	Stro	0-255
		PrG.3	St.68	:	:
				F.din	0-255
				F.tin.	0-25,5 sec
				S.tin.	0-25.5 sec
				CoPY	
SPEC.	rdML				
	rdMH				
	t.LEd	rGbU			
		Sl.Co.			
		SM.Uh.			
	rAdl	SiGn.			
		unLi			
	l.bLi.	On, OFF			
	HOLd	On, Off			
	F.FrE	On,OFF			
	tilt				
	uPd.				

6. Fixture menu

To browse the fixture menu, use e.g. the Robe Universal Interface WTX (RUNIT VTX).

If you control the fixture by means of a DMX cable, connect the RUNIT WTX with the junction box via shielded twisted-pair cable designed for RS-485 and 5-pin XLR-plug (male).

Run the RDM-network on your computer and click with the right button of the mouse on the fixture and select the **Remote LED display** option from the menu list as shown below.

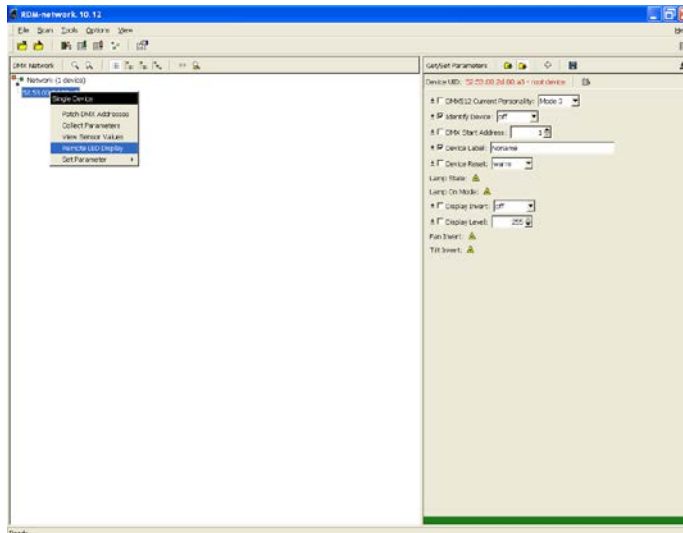

The Remote LED Display window will appear. Now you can fully control the fixture using the **UP**, **Down**, **Enter**, **Escape** and **Reset** buttons.

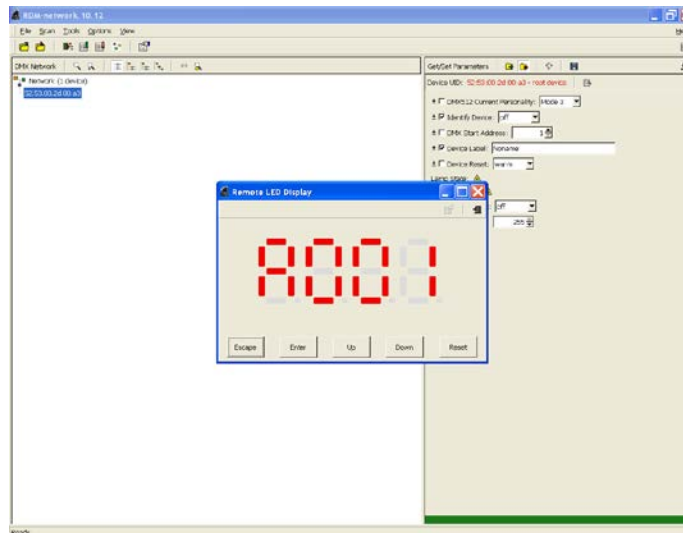

To browse the fixture menu, you can also use the RDM communicator, connect the RDM communicator with the junction box via shielded twisted-pair cable designed for RS-485 and 3-pin or 5-pin XLR-plug (male).



6.1 Fixture Address

A digital display showing the text "A001" in a stylized, outlined font, enclosed in a rectangular border.

Use this menu to set the DMX address of the fixture or set the fixture as a Master (Slave).

dM.Ad. --- **DMX addressing.** Select this submenu to set a DMX start address.

To set a DMX address.

1. Use the UP/DOWN buttons to find “ **A001** ” menu.
2. Press the ENTER button.
3. Use the UP/DOWN buttons to select desired start address.
4. Press the ENTER button to confirm the choice.

Note: After switching on, the ArcSource Inground 24 MC Integral will automatically detect whether DMX 512 data is received or not.

If there is no data received at the DMX input, the display will start to flash with actually set address.

6.2 Fixture information

A digital display showing the text "Info" in a stylized, outlined font, enclosed in a rectangular border.

Use this menu to read useful information about the fixture status.

To display desired information.

1. Use the UP/DOWN buttons to find the “ InFo ” menu.
2. Press the ENTER button.
3. Use the UP/DOWN buttons to select the required menu item.
4. Press the ENTER button to confirm the choice.

Po.ti. ---**Power On Time.** Use the menu item to read the number of operation hours of the fixture.

totL - the function shows the total number of the operation hours since the ArcSource Inground 24 MC Integral has been fabricated.

rSEt - the function shows the number of the operation hours that the ArcSource Inground 24 MC Integral has been powered on since the counter was last reset. In order to reset this counter to 0 you have to press and hold the UP and DOWN buttons and at the same time press the ENTER button.

DM.In.---**DMX values.** Select this function to read DMX values of each channel received by the fixture.

tEMP --- **Fixture Temperatures.** Select this menu to read the temperatures of the fixture:

Cur.t. --- the current temperature of the fixture inside.

Hi.tE. - the menu item shows the max. temperatures of the fixture inside since the ArcSource Inground 24 MC Integral has been fabricated.

rSEt --- the menu item shows the maximum temperatures of the fixture inside since the counter was last reset. In order to reset this counter to 0 you have to press and hold the UP and DOWN buttons and at the same time press the ENTER button.

The temperatures can be displayed in either °C or °F units - see option “tEM.U” in the menu “Pers”.

VErS.---**Software Versions.** Select this function to read the software version of the fixture processors IC1 and IC2.

6.3 Personality



Use this menu to modify the ArcSource Inground 24 MC Integral operating behaviour.

DM.Pr. --- **DMX preset.** Select this menu item to set a desired DMX mode. Please refer to the chapter "DMX protocol" for detail description of each DMX mode.

rAd.t. --- **Unlink time.** Use this menu to set time after that the linked fixture will be unlinked from the transmitter, if the transmitter does not transmit DMX signal. In case that DMX cable is connected to the fixture and "wired DMX" is present on it after unlinking the fixture, the fixture will start to receive "wired DMX".

Off --- Fixture is unlinked after 168 hrs (7 days) with deviation of +/-10%.

0.1-25.5 --- Time from 0.1hr (6 minutes)-25.5 hrs. Default value is 1 hour.

M. F. ti --- **Max. Fade time.** Select this menu item to set a desired max. fade time (0-25.5 sec.). This adjusted fade time influences fade of Red, Green, Blue, White and dimmer during DMX operation:

If time between two receiving DMX values is > than fade time set in the item "M Ftime", the entire adjusted fade time will be used.

If time between two receiving DMX values is < than fade time set in the item "M Ftime", the adjusted fade time will be reduced to fill entire time between the two receiving DMX values.

e.g "M Ftime"=2sec. and fixture has received Red=0 DMX, after 5 seconds will receive Red=255 DMX. It means, that red will go to full intensity during 2 seconds.

"M Ftime"=8 sec. and fixture has received Red=0 DMX, after 5 seconds will receive Red=255 DMX. It means, that red will go to full intensity during 5 seconds. (Max, fade time is reduced from 8 sec. to 5 sec.).

rGb.C. --- **RGB counting.** If this function is active, the white channel (channel 4) uses red, green and blue channels in proportional relation to ensure max. light output in a white colour (if white channel =full, also red, green and blue channels are full).

tEM.U. --- **Temperature Unit.** Use this menu in order to display the fixture temperatures in desired units: °C or °F.

Led.E. --- **Error signalling.** If this item is on, the red signal LED (under the front glass cover of the fixture) gives information about wireless DMX operation.

Signal LED state	Meaning
LED off	DMX data is received, fixture is linked
1x flash	DMX data missing, fixture is linked
2x flash	Fixture is unlinked

Flash (flashes) will appear every 5 seconds:

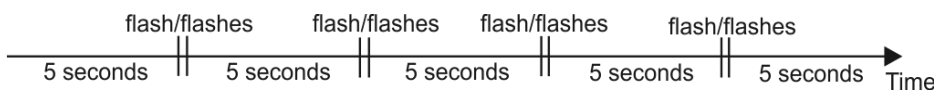

If the item "Led.E" is off, signalling of the red LED is disabled.

In.Po. --- **Init effect positions.** Use this function to set all effects to the desired positions to which they will move after switching the fixture on (if DMX is not being received).

dF.SE. --- **Default Settings.** The menu item sets all fixture parameters to the default (factory) values.

6.4 Manual mode



Use this menu for control the fixture without connected DMX console.

To control fixture channels.

1. Use the UP/DOWN buttons to find " Man.M" menu.
2. Press the ENTER button.
3. Use the UP/DOWN buttons to select desired effect (channel).

List of control channels:

"rEd" - red LEDs saturations

"GrEn" - green LEDs saturations

"bLuE" - blue LEDs saturations

"Uhi" - white LEDs saturations

"CtC" – a colour temperature correction

"C. UhE" - a virtual colour wheel

"Stro." - a strobe, shutter

"dir" - a dimmer

"F.dir" - a fine dimmer

4. Press the ENTER button and use the UP/DOWN buttons to set value , press the ENTER button to confirm it.

6.5 Test sequences



Use this menu to run demo-test sequences without an external controller, which will show you some possibilities of using the ArcSource Inground 24 MC Integral.

6.6 Stand-alone setting



The fixture is not connected to the controller but can execute pre-set program.

Auto. --- **Automatic playback.** This function allows you to select the program which will be played after switching the fixture on. Selected program will be played continuously in a loop.

PLAY --- **Playing program.** By enter to this menu a complete overview of all programs is offered, from which the program to be run can be selected.

Edit --- **Editing a program.** The fixture offers 3 freely editable programs (PrG.1, PrG.2, PrG.3) each up to 40 steps. Every program step includes a fade time (F.tin.) - the time taken by the step's channel status to reach the desired level and a step time (S.tin.) - the total time occupied by the step in the program.

E.g. If "F.tin."=5 second and "S.tin."=20 second, effects will go to the desired position during 5 seconds and after that they will stay in this position for 15 seconds before going to the next prog. step

1. Use the UP/DOWN buttons to find " St.AL." menu and press the ENTER button.
2. Use the UP/DOWN buttons to select "Edit" menu and press the ENTER button.
3. Use the UP/DOWN buttons to select a program you want to edit (PrG.1-PrG.3) and press ENTER button.
4. Use the UP/DOWN buttons to select a desired program step ("St.01" - "St.40") and press ENTER button.
5. Use the UP/DOWN buttons to select a channel you want to edit and press the ENTER button.

List of editable items:

"P.End" - a total number of the program steps (value 1-40). This value should be set before start programming (e.g. if you want to create program with 10 steps, set P.End=10).

"rEd" - red LEDs saturations

"GrEn" - green LEDs saturations

- “bLuE” - blue LEDs saturations
- “Uhi” - white LEDs saturations
- “CtC” – a colour temperature correction
- “C. UHE” - a virtual colour wheel
- “Stro.” - a strobe, shutter
- “dinr” - a dimmer
- “F.din” - a fine dimmer
- “F.tin.” - a fade time, (0-25.5) seconds
- “S.tin.” - step time, value (0-25.5) seconds
- “CoPY”. – this item duplicates the current prog. step to the next prog. step. The item “P.End” is increased automatically.

6. Use the UP/DOWN buttons to set a DMX value of the channel and then press the ENTER button.
7. Use the UP/DOWN buttons to select next channel and press the ENTER button.
8. After having set all channels in the current program step, press the MODE button to go by one menu level back and select another program step.

6.7 Special functions



rdML --- **Code.** This menu item shows the first part of the RDM identification code.

rdMH --- **Code.** This menu item shows the second part of the RDM identification code.

t.LEd --- **Type of LEDs.** The menu serves for setting control of the fixture according colour combination of LEDs.

rGbU --- RGBW version

Si.Co. --- Single colour version

SM.Uh. --- Smart white version

Note: Do Not change the factory setting!

rAdI --- **Wireless DMX (only wireless DMX version).** The menu serves for reading of the wireless operation status.

SiGn. --- **Signal level.** The menu item shows level of received signal in %. If the fixture is not linked to the transmitter, “no.LI” is displayed.

unLi --- **Wireless DMX unlink.** The item serves for unlinking the fixture from transmitter.

I. bli. --- **Initial blink.** If this function is on, the fixture makes auto-calibration (each LED colour lit on 100% for short time) after switching the fixture on.

HoLd --- If the function is on, the fixture keeps last received DMX values in case that DMX data receiving was interrupted (e.g. disconnected DMX cable or DMX controller...). The setting of this function goes for wired DMX as well as for wireless DMX.

F. FrE---**Flicker free mode.** If the function is on, the light flickering visible in cameras is corrected but colour uniformity is worse.

tilt---**Tilt of the light beam.** The menu item allows to set desired tilt of the light beam. During adjusting position of the light beam, the white beam will appear.

Adj. - **Adjustment.** The menu allows the fine adjustment of colours.

Man.M.- **Manual mode.** Use the menu to set DMX values of fixture’s channels.

Cal. C. - A calibration of red, green, blue and white colours by means of an automatic calibration with a factory equipment (RGBW version only).

Red C – red LEDs saturation (0-255)

Grn C – green LEDs saturation (0-255)

Blu C – blue LEDs saturation (0-255)

Uhi C – white LEDs saturation (0-255)

SAUE – saves adjusted values

Cal. t. – Selection of colour temperature for manual calibration: 2700K, 3200K, 4200K, 5600K, 8000K.

Manual colour calibration:

1. Connect the fixture to the mains, unlink DMX, go to the “Man. M.” menu and set the shutter, dimmer, red, green, blue and white channel at 255 DMX and let the fixture heat up.
2. Go to the “Man. M.” menu and set the C UH at 1 DMX (2700K)
3. Go to the “Cal t.” menu, select “2700K” item and by means of the rEd. C. , GrE. C. , blu. C. and Uhi. C. items adjust the 2700K colour temperature as exactly as possible ($\Delta u'v' = 0$).
After calibration, press the “SAUE” item to save adjusted values.
4. Go to the “Man. M.” menu and set the C UH at 4 DMX (3200K).
5. Go to the “ Cal t. ” menu, select “3200K” item and by means of the rEd. C. , GrE. C. , blu. C. and Uhi. C. items adjust the 3200K colour temperature as exactly as possible ($\Delta u'v' = 0$).
After calibration, press the “SAUE” item to save adjusted values.
6. Repeat this procedure for rest of colour temperatures (4200K, 5600K, 8000K).

uPd. --- **Updating mode.** The following are required in order to update software in the ArcSource Inground 24 MC Integral:

- PC running Windows 7/8 /Linux/OSX with connection to the Internet
- ROBE RDM Uploader software
- Robe Universal Interface WTX (RUNIT WTX)

Note: Both software update and case software update should execute a qualified person. If you lack qualification, do not attempt the update yourself and ask for help your Anolis distributor.

Note: programs 1-3 and all items in the menu "PErS" and "SPEC" will be set to their default values after software update.

To update software in the fixture

I. Installation of the ROBE RDM Uploader.

1. The RDM Uploader is available from the ROBE web site at WWW.robe.cz.
2. Make a new directory (e.g. Robe_Uploader) on your hard disk and download the software into it.
3. Install the software on your computer.

II. Fixture software updating.

1. Connect RUNIT WTX with the fixture via DMX cable.
2. Connect your PC with the USB input of the RUNIT WTX.
3. Run the ROBE RDM Uploader and perform software update of the fixture (see the RDM Uploader manual). Avoid interrupting the update process.

7. RDM

This fixture is ready for RDM operation. RDM (Remote Device Management) is a bi-directional communications protocol for use in DMX512 control systems, it is the new open standard for DMX512 device configuration and status monitoring.

The RDM protocol allows data packets to be inserted into a DMX512 data stream without adversely affecting existing non-RDM equipment. By using a special „Start Code,“ and by complying with the timing specifications for DMX512, the RDM protocol allows a console or dedicated RDM controller to send commands to and receive messages from specific moving lights.

RDM allows explicit commands to be sent to a device and responses to be received from it.

The list of commands for ArcSource Inground 24 MC Integral is the following.

ArcSource Inground 24 MC Integral

Parameter ID	Discovery command	SET command	GET command
DISC_UNIQUE_BRANCH	*		
DISC_MUTE	*		
DISC_UN_MUTE	*		
DEVICE_INFO			*
SUPPORTED_PARAMETERS			*
SOFTWARE_VERSION_LABEL			*
DMX_START_ADDRESS		*	*
IDENTIFY_DEVICE		*	*
DEVICE_MODEL_DESCRIPTION			*
MANUFACTURER_LABEL			*
DEVICE_LABEL		*	*
SENSOR_DEFINITION			*
SENSOR_VALUE			*
DISPLAY_LEVEL		*	*
DEVICE_RESET		*	
DMX_PERSONALITY		*	*
DMX_PERSONALITY_DESCRIPTION			*
STATUS_MESSAGES			*
STATUS_ID_DESCRIPTION			*
DEVICE_HOURS			*

8. Technical specifications

Power supply

- Electronic auto-ranging
- Input voltage: 100 – 277 V AC, 50-60 Hz
- Max. power consumption: 65W @ 230V (Power factor=0.83)

Optic & Effects

- Light source: 6 x LED multichip(RGBW, SW)
- Available beam angles: 7°, 24°, 34°, 42°x7° (standard), 7°x42°
- RGBW colour mixing
- Virtual colour wheel
- Adjustable strobe sequences
- Pre-set whites (2700K, 3200K, 4200K, 5600K, 8000K)
- typical Lumen maintenance: 70%@ 60,000 hours

Control

- USITT DMX 512, RDM
- DMX protocol modes: 4 (2,3,4,9 control channels)
- Operations modes: DMX, Stand-alone
- Manual control of all effects via RUNIT WTX or RDM Communicator
- 3 user editable programs each up to 40 steps.

Wireless DMX/RDM module (for wireless DMX version only: ArcSource Inground 24 MC Integral /W)

- Compliance with USITT DMX-512 (1986 & 1990) and 512-A
- Full DMX fidelity and frame integrity
- Auto sensing of DMX frame rate and frame size
- <5ms DMX latency
- Operational frequency range of 2402-2480 MHz
- Producer: LumenRadio

Strobe

- Strobe effect with variable speed (max. 20 flashes per second)
- Pre-programmed random strobe pulse-effects

Dimmer

- Smooth 16-bit dimming from 0 - 100 %

Temperatures

- Maximum surface temperature of the sleeve: +40°C/+104°F
- Minimum surface temperature of the sleeve: -20°C/-4°F
- Max. temperature on the transparent cover: +55°C/131°F (at sleeve surface temperature=40°C/104°F)

Overheating protection

- LED module and power source

Construction

- Housing: high pressure die cast aluminium-anodizing
- Transparent cover: tempered glass
- Flange: stainless steel 316L
- Installation sleeve: stainless steel 316L (Welded)
- silicone rubber gasket

Directionally adjustable mechanism

- Motorized tilt $\pm 15^\circ$

ArcSource Inground 24 MC Integral

Weight

- 18.2 kg (9.2 kg sleeve, 9 kg ArcSource Inground 24 MC Integral)

Protection factor

- CE: IP 68 (1m for 8 hours)
- US: Suitable for wet locations
 - Suitable for use in poured concrete
 - Suitable for ground mounted recessed only

Impact rating

- IK10

Static load resistance

- 35kN

Electric connection

- Junction box at bottom side of the ArcSource Inground 24 MC Integral

Included items

- 1 x ArcSource Inground 24 MC Integral
- 1 x Installation sleeve
- 1 x Installation parts (flange, screws)
- 4 x Reducing seal P/N 13051388 (for cables of diameter 4-8mm)
- 1 x Magnetic chip (for wireless DMX version)
- 1 x User manual

Dimensions (mm)

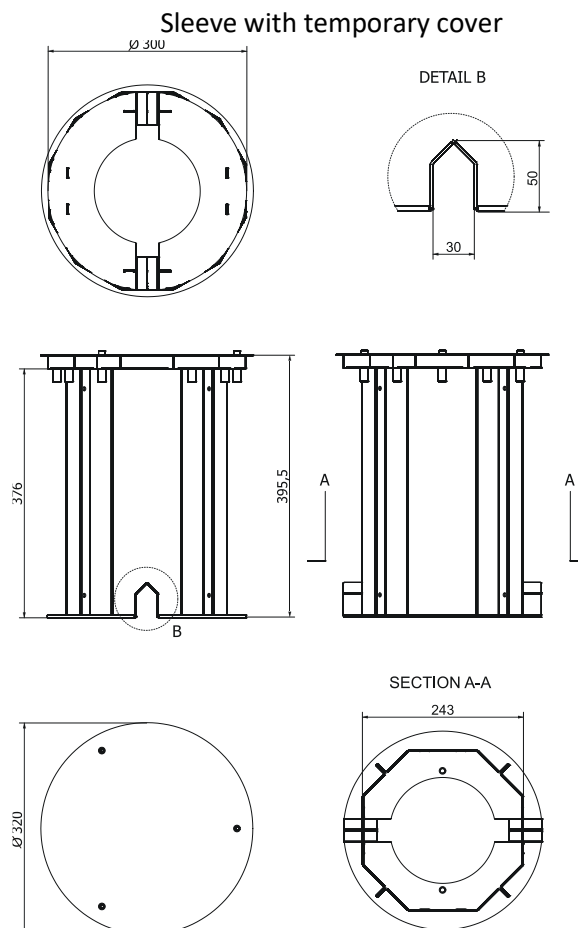

ArcSource Inground 24 MC Integral

Sleeve + ArcSource Inground 24 MC Integral

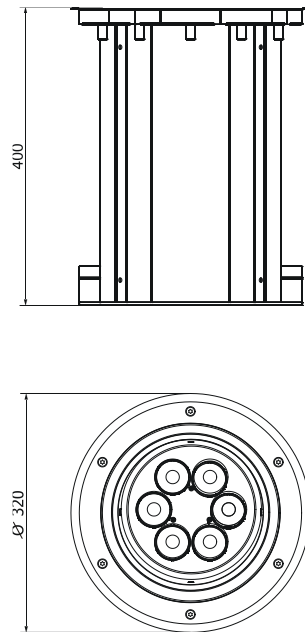

10. Cleaning and maintenance

DANGER !
Disconnect from the mains before starting any maintenance work.

Wash the transparent cover with a soft brush or sponge and a mild, non-abrasive washing detergent. Rinse it. Maintenance and service operations are only to be carried out by a qualified person.

Should you need any spare parts, please use genuine parts.

In case that the glass cover has been broken, the product cannot be used and you should contact the Anolis distributor for service intervention.

Specifications are subject to change without notice

December 4, 2017

Made in CZECH REPUBLIC by ROBE LIGHTING s.r.o. Palackeho 416/20 CZ 75701 Valasske Mezirici