

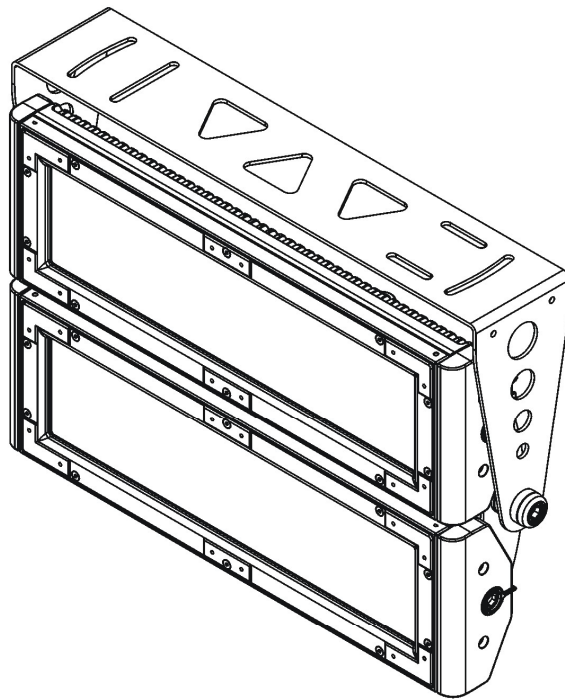

ArcPad Xtreme-CE (RGBW)
ArcPad Xtreme-CE (SW)
ArcPad Xtreme-CE (SC)
ArcPad Xtreme-CE EPS
(Wireless DMX version)



USER MANUAL

Version 2.1

Table of contents

1. Safety instructions	3
2. Fixture exterior view	4
3. Installation	5
3.1 Mounting the fixture	5
3.2 Connection to the mains	6
3.3 Installation of the barn-doors, top/half top hats	7
3.4 Setting and control the fixture	7
4. ArcPad Xtreme - DMX protocols.....	9
4.1 RGBW version (1.0).....	9
4.2 SW version (1.0).....	11
4.3 SC version (1.0)	12
5. Control menu maps	13
5.1 RGBW version (Red,Green,Blue,White).....	13
5.2 SW version (Smart White)	16
5.3 SC version (Single Colour)	19
6. Fixture menu.....	21
6.1 Fixture Address	22
6.2 Fixture information.....	22
6.3 Personality	23
6.4 Manual mode.....	24
6.5 Test sequences.....	24
6.6 Stand-alone setting.....	25
6.7 Special functions.....	26
7. RDM	26
8. Error and information messages	27
9. Technical specifications	28
10. Cleaning and maintenance	31
11. Apendix.....	32
11.1 ArcPad Xtreme EPS	32

**FOR YOUR OWN SAFETY, PLEASE READ THIS USER MANUAL CAREFULLY
BEFORE POWERING OR INSTALLING YOUR ArcPad Xtreme !
Save it for future reference.**

This device has left our premises in absolutely perfect condition. In order to maintain this condition and to ensure a safe operation, it is absolutely necessary for the user to follow the safety instructions and warning notes written in this manual.

The manufacturer will not accept liability for any resulting damages caused by the non-observance of this manual or any unauthorized modification to the device.

Please consider that damages caused by manual modifications to the device are not subject to warranty.

1. Safety instructions

DANGEROUS VOLTAGE CONSTITUTING A RISK OF ELECTRIC SHOCK IS PRESENT WITHIN THIS UNIT!

Make sure that the available voltage is not higher than stated on the rear panel of the fixture.

This fixture should be operated only from the type of power source indicated on the marking label. If you are not sure of the type of power supplied, consult your authorized distributor or local power company.

Always disconnect the fixture from AC power before cleaning, removing or installing the fuses, or any part.

Do not overload wall outlets and extension cords as this can result in fire or electric shock.

Make sure that the power cord is never crimped or damaged by sharp edges. Check the fixture and the power cord from time to time.

Do not install the unit near naked flames.

During the operation the housing becomes hot (up to 85°C)

Refer servicing to qualified service personnel.

This fixture falls under protection class I. Therefore this fixture has to be connected to a mains socket outlet with a protective earthing connection.

Do not connect this fixture to a dimmer pack.

**LED light emission. Risk of eye injury.
Do not look straight at the fixture's LEDs during operation. The intense light beam may damage your eyes.**

Keep combustible materials at least 40 cm away from the fixture.

If the fixture has been exposed to drastic temperature fluctuation (e.g. after transportation), do not switch it on immediately. The arising condensation water might damage your device. Leave the device switched off until it has reached room temperature.

Do not shake the fixture. Avoid brute force when installing or operating the fixture.

The fixture was designed for indoor use and it is intended for professional application only. It is not for household use.

ArcPad Xtreme/W (Wireless DMX version)

When choosing the installation spot, please make sure that the fixture is not exposed to extreme heat or dust.

Avoid using the unit in locations subject to possible impacts.

The fixture body never must be covered with cloth or other materials.

Only operate the fixture after having checked that the housing is firmly closed and all screws are tightly fastened.

Make sure that the area below the installation place is blocked when rigging, derigging or servicing the fixture.

Do not block the front objective LEDs with any object when the fixture is under operation.

The fixture becomes very hot during operation. Allow the fixture to cool approximately 40 minutes prior to manipulate with it.

Operate the fixture only after having familiarized with its functions. Do not permit operation by persons not qualified for operating the fixture. Most damages are the result of unprofessional operation!

Do not attempt to dismantle or modify the unit.

Please consider that unauthorized modifications on the fixture are forbidden due to safety reasons!

Please use the original packaging if the fixture is to be transported.

If this device will be operated in any way different to the one described in this manual, the product may suffer damages and the guarantee becomes void. Furthermore, any other operation may lead to dangers like short-circuit, burns, electric shock etc.

2. Fixture exterior view

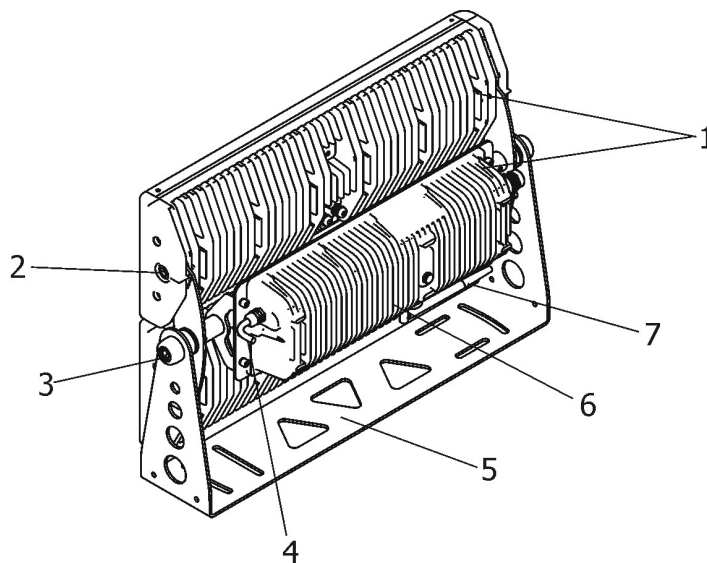

1. LED modules
2. Tilt-locks for LED modules
3. Tilt-lock for both LED modules
4. Power cable

5. Mounting bracket
6. Control unit
7. Antenna

3. Installation

3.1 Mounting the fixture

Ensure that the structure (truss, wall) to which you are attaching the fixture is secure.

The ArcPad Xtreme can be arranged in any position orientation. The ArcPad Extreme allows to adjust its LED modules to the desired position either both modules together (by means of the Allen key 14) or each module separately (by means of the self-locking screws).

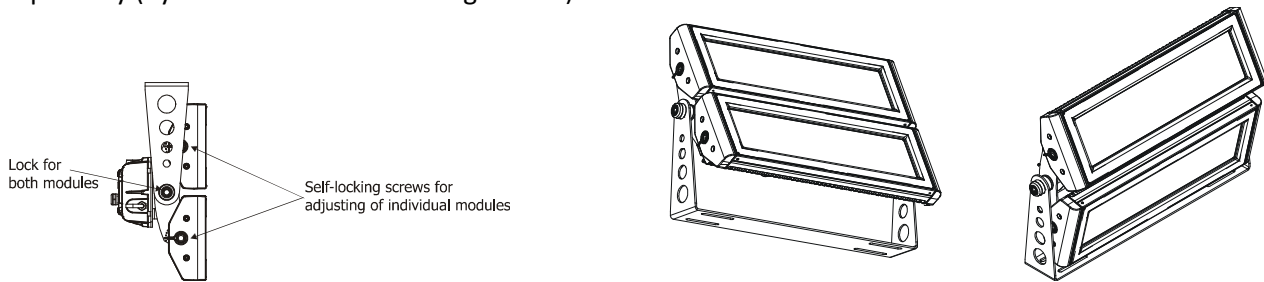

Danger of injury! Two workers have to handle with the fixture including adjusting the LED modules to the desired position. The LED modules are very heavy.

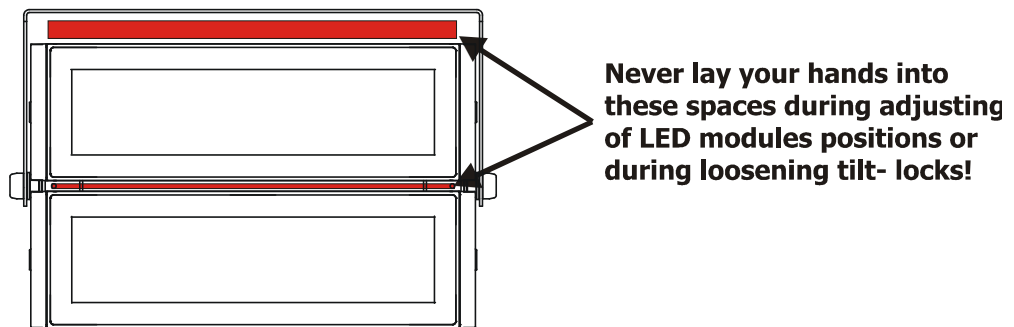

Five slots in the mounting bracket serve for mounting the fixture on non-flammable flat surface.

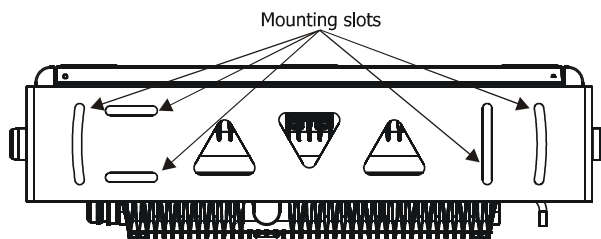

Caution: Overhead installation requires experience. Fixtures may cause severe injuries when crashing down! If you have doubts concerning the safety of a possible installation, do not install the device and consult installation with an expert.

Warning!
The antenna must be installed on the fixture to keep declared IP rating of the fixture!

3.2 Connection to the mains

Fixtures must be installed by a qualified electrician in accordance with all national and local electrical and construction codes and regulations

The ArcPad Xtreme is equipped with a 5-cored power/data cable. The 3 cores serve for the power supply and next 2 shielded cores are intended for DMX connection.

The power cores are coloured according to the following table.

Core	Connection	Core	Connection
Black	Live	Red	Data +
Blue	Neutral	White	Data -
Yellow/Green	⏚	Shielding	0

This device falls under class one and must be grounded!

The power cable is connected to a junction box as shown on the picture below.

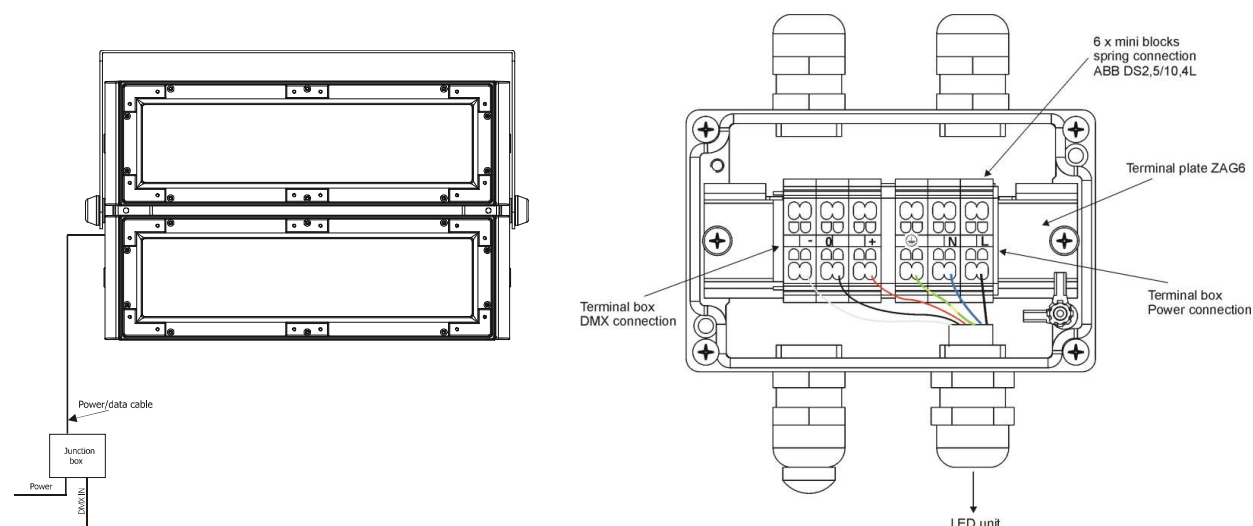

Connect the junction box according to the tables below

Power connection

	L	N	⏚
EU	Braun	Blue	Green/yellow
US	Black	White	Green

DMX connection

+	0	-
Data +	Data ground(shielding)	Data -

3.3 Installation of the barn-doors, top/half top hats

You can install barn-doors or top hats to better define illuminated surface.

Before installing the equipment disconnect the fixture from the mains.

1. Fit the barn-doors module (1) or top/half top hat (2) on the LED module (4) and fasten it by means of the 12 screws (3) as shown on the picture below.
2. Repeat the same steps for the second LED module of the fixture.

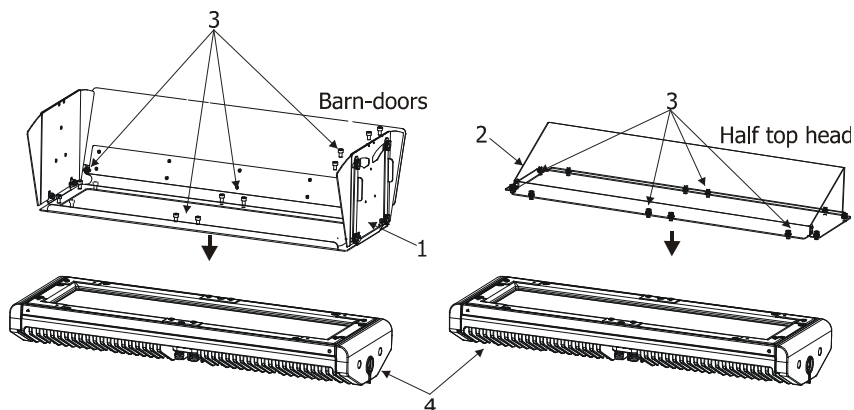

Never close the barn-doors during fixture operation!

3.4 Setting and control the fixture

For setting DMX address, selecting DMX mode and for another settings you need either Robe Universal Interface WTX or the RDM Communicator. Please see the Robe Universal Interface WTX or RDM Communicator user manuals to get more information about this products. The way, how to connect these interfaces to the DMX data link is figured below.

1. RDM Communicator

Note: DMX controller has to be disconnected from the fixture when the RDM communicator is operated

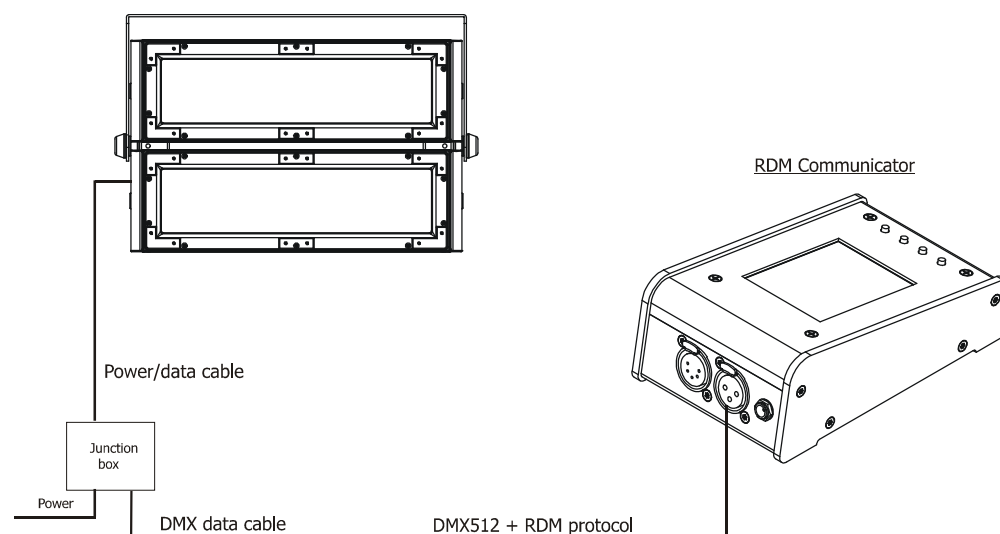

2.Robe Universal Interface WTX

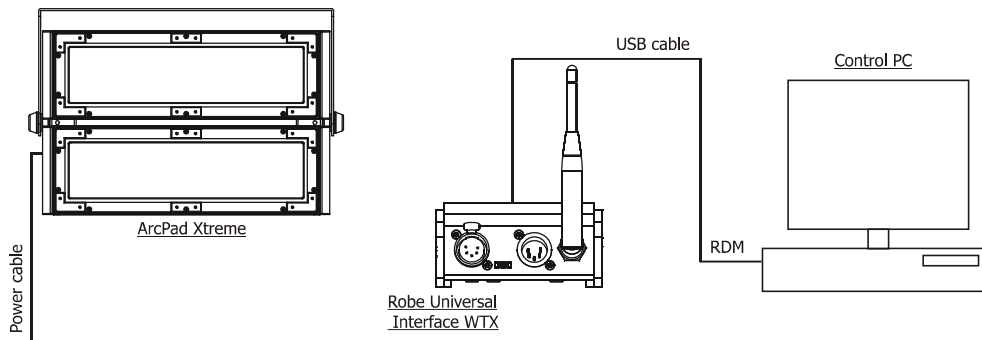

The fixture is equipped with the Lumen Radio CRMX module and antenna for receiving DMX signal. CRMX module operates on the 2.4 GHz band.

To link the fixture with DMX transmitter.

The fixture can be only linked with the transmitter by running the link procedure at DMX transmitter . After linking , the level of DMX signal (0-100 %) is displayed in the menu item “**r.InF**” (SPEC-->rAdl.--> r.InF.)

To unlink the fixture from DMX transmitter.

The fixture can be unlinked from receiver via the menu item “ **r.UnL.**” (SPEC-->rAdl.--> r.UnL.).

4. ArcPad Xtreme - DMX protocols

4.1 RGBW version (1.0)

Mode/Channel						Value	Function	Type of control
1	2*	3	4	5	6			
-	1	1	1	-	-	0 - 255	Red LEDs - both LED modules Red LEDs saturation control (0-100%)	proportional
-	2	2	2	-	-	0 - 255	Green LEDs - both LED modules Green LEDs saturation control (0-100%)	proportional
-	3	3	3	-	-	0 - 255	Blue LEDs - both LED modules Blue LEDs saturation control (0-100%)	proportional
-	-	4	4	-	-	0 - 255	White LEDs - both LED modules White LEDs saturation control (0-100%)	proportional
-	-	-	-	1	1	0 - 255	Red LEDs – LED module 1 Red LEDs saturation control (0-100%)	proportional
-	-	-	-	2	2	0 - 255	Green LEDs - LED module 1 Green LEDs saturation control (0-100%)	proportional
-	-	-	-	3	3	0 - 255	Blue LEDs - LED module 1 Blue LEDs saturation control (0-100%)	proportional
-	-	-	-	4	4	0 - 255	White LEDs - LED module 1 White LEDs saturation control (0-100%)	proportional
-	-	-	-	5	5	0 - 255	Red LEDs - LED module 2 Red LEDs saturation control (0-100%)	proportional
-	-	-	-	6	6	0 - 255	Green LEDs - LED module 2 Green LEDs saturation control (0-100%)	proportional
-	-	-	-	7	7	0 - 255	Blue LEDs - LED module 2 Blue LEDs saturation control (0-100%)	proportional
-	-	-	-	8	8	0 - 255	White LEDs - LED module 2 White LEDs saturation control (0-100%)	proportional
1	-	-	5	-	9	0 1-15 16 17-55 56 57 - 95 96 97 – 134 135 136 - 174 175 176 -214 215	Colour macros (255 values) – both LED modules No function (for DMX mode 4 and 6) White (for DMX mode 1) White tones (cool→warm) Blue (Blue=full, Red+Green+White=0) Red=0, Green→up, Blue =full, White=0 Light Blue (Red=0, Green=full, Blue =full, White=0) Red=0, Green=full, Blue→down, White=0 Green (Red=0, Green=full, Blue =0, White=0) Red→up, Green=full, Blue=0, White=0 Yellow (Red=full, Green=full, Blue=0, White=0) Red=full, Green→down, Blue=0, White=0 Red (Red=full, Green=0, Blue=0, White=0) Red=full, Green=0, Blue→up, White=0 Magenta (Red=full, Green=0, Blue=full, White=0)	step proportional step proportional step proportional step proportional step proportional step

ArcPad Xtreme/W (Wireless DMX version)

Mode/Channel						Value	Function	Type of control
1	2*	3	4	5	6			
1	-	-	5	-	9	216 - 254 255	<u>Colour macros – both LED modules</u> Red→down, Green=0, Blue=full, White=0 Blue (Red=0, Green=0, Blue=full, White=0)	proportional step
-	-	-	6	-	10	0-31 32-63 64-95 96-127 128-143 144-159 160-191 192-223 224-255	<u>Shutter/ Strobe – both LED modules</u> Shutter closed Shutter open Strobe-effect from slow to fast Shutter open Opening pulses in sequences slow--> fast Closing pulses in sequences fast --> slow Shutter open Random strobe-effects from slow to fast Shutter open	step step proportional step proportional proportional step proportional step
2	-	-	7	-	11	0 - 255	<u>Dimmer – both LED modules</u> Dimmer intensity from 0% to 100%	proportional
-	-	-	8	-	12	0 - 255	<u>Dimmer fine – both LED modules</u> Fine dimmer intensity from low to high	proportional

*White LEDs lit proportionally when Red+Green+Blue LEDs are saturated together.

4.2 SW version (1.0)

Mode				Value	Function	Type of control
1	2	3	4			
1	-	1	-	0 - 255	Warm white –both LED modules Warm white LEDs saturation control (0-100%)	proportional
2	-	2	-	0 - 255	Cool white – both LED modules Cool white LEDs saturation control (0-100%)	proportional
-	-	-	1	0 - 255	Warm white –LED module 1 Warm white LEDs saturation control (0-100%)	proportional
-	-	-	2	0 - 255	Cool white –LED module 1 Cool white LEDs saturation control (0-100%)	proportional
-	-	-	3	0 - 255	Warm white –LED module 2 Warm white LEDs saturation control (0-100%)	proportional
-	-	-	4	0 - 255	Cool white –LED module 2 Cool white LEDs saturation control (0-100%)	proportional
-	1	-	-	0-127	Ratio control – both LED modules* 100% Warm white LEDs saturation, cool white LEDs saturation 0%-->100%	proportional
-	-	-	-	128-255		100% Cool white LEDs saturation, warm white LEDs saturation 100%-->0%
-	-	3	5	0-31 32-63 64-95 96-127 128-143 144-159 160-191 192-223 224-255	Strobe –both LEDmodules Shutter closed Shutter open Strobe-effect from slow to fast Shutter open Opening pulses in sequences slow--> fast Closing pulses in sequences fast --> slow Shutter open Random strobe-effects from slow to fast Shutter open	step step proportional step proportional proportional step proportional step
-	2	4	6	0 - 255	Dimmer–both LED modules Dimmer intensity from 0% to 100%	proportional
-	-	5	7	0 - 255	Dimmer fine–both LED modules Fine dimmer intensity from low to high	proportional

*Ratio control:

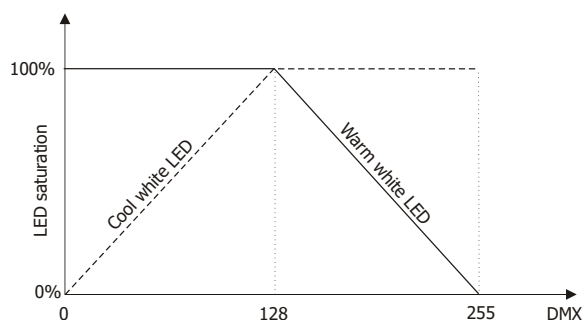

4.3 SC version (1.0)

Mode				Value	Function	Type of control
1	2	3	4			
-	-	1	1	0 - 255	<u>Dimmer –LED module 1</u> Dimmer intensity from 0% to 100%	proportional
-	-	2	2	0 - 255	<u>Dimmer –LED module 2</u> Dimmer intensity from 0% to 100%	proportional
-	1	-	3	0-31 32-63 64-95 96-127 128-143 144-159 160-191 192-223 224-255	<u>Strobe –both LED modules</u> Shutter closed Shutter open Strobe-effect from slow to fast Shutter open Opening pulses in sequences slow--> fast Closing pulses in sequences fast --> slow Shutter open Random strobe-effects from slow to fast Shutter open	step step proportional step proportional proportional step proportional step
1	2	-	4	0 - 255	<u>Dimmer–both LED modules</u> Dimmer intensity from 0% to 100%	proportional
-	3	-	5	0 - 255	<u>Dimmer fine–both LED modules</u> Fine dimmer intensity from low to high	proportional

5. Control menu maps

5.1 RGBW version (Red,Green,Blue,White)

Default settings=**Bold print**

Menu Level 1	Menu Level 2	Menu Level 3	Menu Level 4	Menu Level 5	Menu Level 6
A001	dM.Ad.	001-512			
	MA.SL.	d.AbL			
		MASt.			
		SLA			
InFo	Poti.	totL	totL		
		rSEt	rSEt		
	DM.In.	rEd1	0-255		
		:			
		F.dim	0-255		
	tEMP.	Cur.t.	boAr.		
			LEdS		
		Hi.tE.	boAr.		
			LEdS		
		rSEt	boAr.		
			LEdS		
	VERs.	IC1			
		IC2			
PERs	dM.Pr.	Mod.1			
		Mod.2			
		Mod.3			
		Mod.4			
		Mod.5			
		Mod.6			
	dISP.	d.On	On, Off		
		d.Int.	20...100		
		turn	On, Off		

ArcPad Xtreme/W (Wireless DMX version)

Menu Level 1	Menu Level 2	Menu Level 3	Menu Level 4	Menu Level 5	Menu Level 6
	tEM.U.	°C, °F			
	bALA	On, Off			
	C.bAL.	rEd	0.. 200 ..255		
		GrEn	0..... 255		
		bLuE	0.. 237 ..255		
		Stor			
	LOAd	FuLL			
		EcO			
	In.Po.	rEd1	0-255		
		:			
		F.dim	0-255		
		Stor.			
	dFSE				
MAAn.M.	PrE.C.	rEd1	rE1.1..rE1.3		
		:			
		dimr	dim0...dim.7		
	Man.C.	rEd1	0-255		
		:			
		F.dim	0-255		
TESt					
St.AL.	Auto	Off			
		tESt			
		PrG.1			
		:			
		PrG.3			
	PLAY	tESt			
		PrG.1			
		:			

ArcPad Xtreme/W (Wireless DMX version)

Menu Level 1	Menu Level 2	Menu Level 3	Menu Level 4	Menu Level 5	Menu Level 6
		PrG.3			
	Edit	PrG.1	St.01	rEd1	0-255
		:	:	:	:
		PrG.3	St.68	S.tim.	0-25.5 sec
				CoPY	
SPEC.	rdML				
	rdMH				
	Adj.	DMH	rEd1		
			:		
			F.dimr		
		CaL.U.	rEd1		
			:		
			Wh4		
			Stor.		
	Hold	On, Off			
	uPd.				

5.2 SW version (Smart White)

Default settings=Bold print

Menu Level 1	Menu Level 2	Menu Level 3	Menu Level 4	Menu Level 5	Menu Level 6
A001	dM.Ad.	001-512			
	MA.SL.	d.AbL			
		MASt.			
		SLA			
InFo	Poti.	totL	totL		
		rSEt	rSEt		
	DM.In.	Uhi1	0-255		
		:			
		dinr	0-255		
	tEMP.	Cur.t.	boAr.		
			LEdS		
		Hi.tE.	boAr.		
			LEdS		
		rSEt	boAr.		
			LEdS		
	VErS.	IC1			
		IC2			
PErS	dM.Pr.	Mod.1			
		Mod.2			
		Mod.3			
		Mod.4			
	dISP.	d.On	On, Off		
		d.Int.	20...100		
		turn	On, Off		
	tEM.U.	°C, °F			
	LOAd	FuLL			

ArcPad Xtreme/W (Wireless DMX version)

Menu Level 1	Menu Level 2	Menu Level 3	Menu Level 4	Menu Level 5	Menu Level 6
		EcO			
	In.Po.	Uhi1	0-255		
		:			
		F.din	0-255		
		Stor.			
	dFSE				
MAn.M.	PrE.C.	Uhi1	Uh0.1..Uh0.3		
		:			
		F.dim	dim0...dim.7		
	Man.C.	Uhi1	0-255		
		:			
		F.dim	0-255		
TESt					
St.AL.	Auto	Off			
		tEst			
		PrG.1			
		:			
		PrG.3			
	PLAY	tEst			
		PrG.1			
		:			
		PrG.3			
	Edit	PrG.1	St.01	Whi1	0-255
		:	:	:	:
		PrG.3	St.68	S.tim.	0-25.5 sec
				CoPY	

ArcPad Xtreme/W (Wireless DMX version)

Menu Level 1	Menu Level 2	Menu Level 3	Menu Level 4	Menu Level 5	Menu Level 6
SPEC.	rdML				
	rdMH				
	Adj.	DMH	Uhi1		
			:		
			F.dim		
		CaL.U.	Uhi1		
			:		
			Uhi4		
			Stor.		
	Hold	On, Off			
	uPd.				

5.3 SC version (Single Colour)

Default settings=Bold print

Menu Level 1	Menu Level 2	Menu Level 3	Menu Level 4	Menu Level 5	Menu Level 6
A001	dM.Ad.	001-512			
	MA.SL.	d.AbL			
		MASt.			
		SLA			
InFo	Poti.	totL	totL		
		rSEt	rSEt		
	DM.In.	rEd1	0-255		
		:			
		F.dim	0-255		
	tEMP.	Cur.t.	boAr.		
			LEdS		
		Hi.tE.	boAr.		
			LEdS		
		rSEt	boAr.		
			LEdS		
	VErS.	IC1			
		IC2			
PErS	dM.Pr.	Mod.1			
		Mod.2			
		Mod.3			
		Mod.4			
	dISP.	d.On	On, Off		
		d.Int.	20...100		
		turn	On, Off		
	tEM.U.	°C, °F			
	LOAd	FuLL			

ArcPad Xtreme/W (Wireless DMX version)

Menu Level 1	Menu Level 2	Menu Level 3	Menu Level 4	Menu Level 5	Menu Level 6
		EcO			
	In.Po.	CoL.1	0-255		
		:			
		F.dim	0-255		
		Stor.			
	dFSE				
MAn.M.	PrE.C.	CoL.1	Co1.1..Co1.3		
		:			
		dimr	dim0...dim.7		
	Man.C.	rEd1	0-255		
		:			
		F.dim	0-255		
TESt					
St.AL.	Auto	Off			
		tEst			
		PrG.1			
		:			
		PrG.3			
	PLAY	tEst			
		PrG.1			
		:			
		PrG.3			
	Edit	PrG.1	St.01	CoL.1	0-255
		:	:	:	:
		PrG.3	St.68	S.tim.	0-25.5 sec
				CoPY	
SPEC.	rdML				

ArcPad Xtreme/W (Wireless DMX version)

Menu Level 1	Menu Level 2	Menu Level 3	Menu Level 4	Menu Level 5	Menu Level 6
	rdMH				
	Adj.	DMH	CoL.1		
			:		
			F.dimr		
		CaL.U.	CoL.1		
			:		
			CoL.16		
			Stor.		
	Hold	On, Off			
	uPd.				

6. Fixture menu

To browse the fixture menu, use the Robe Universal Interface WTX :

Run the RDM-network on your computer and click with the right button of the mouse on the fixture and select the **Remote LED display** option from the menu list as shown below.

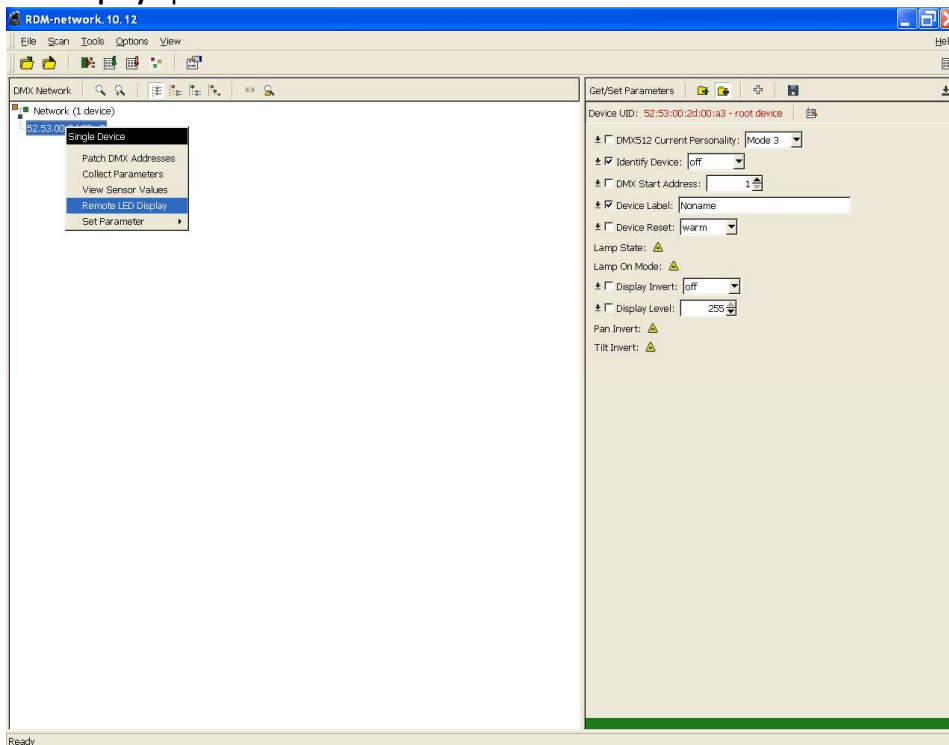

The Remote LED Display window will appear. Now you can fully control the fixture using the **UP**, **Down**, **Enter**, **Escape** and **Reset** buttons.

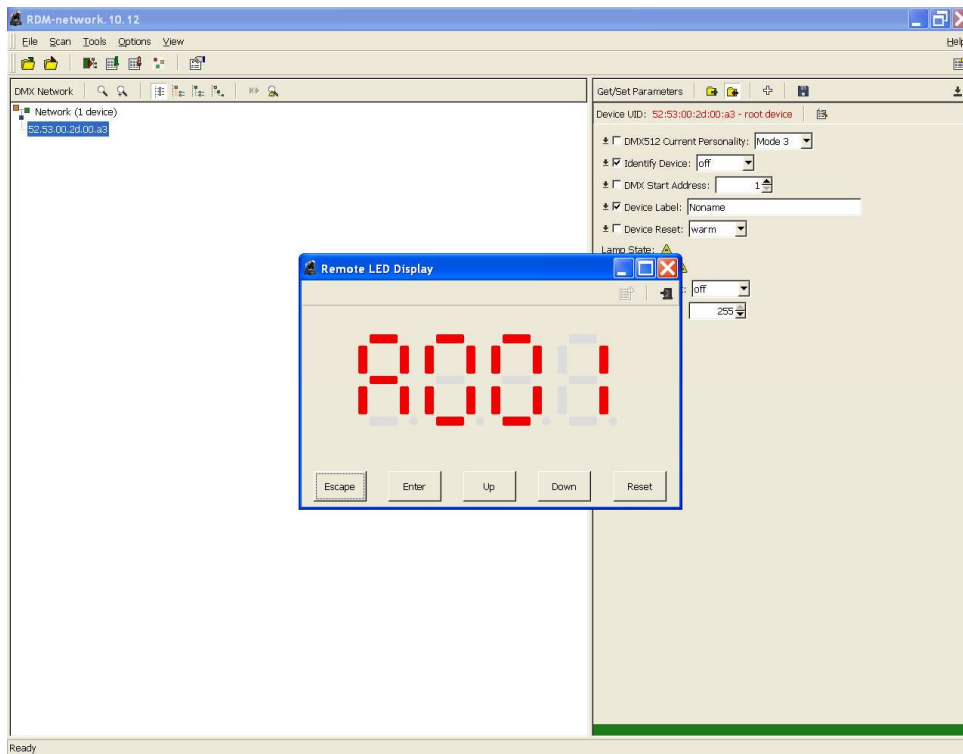

6.1 Fixture Address



Use this menu to set the DMX address of the fixture.

dM.Ad. --- **DMX addressing.** Select this submenu to set a DMX start address.

To set a DMX address.

1. Use the UP/DOWN buttons to find “ **A001** ” menu.
2. Press the ENTER button.
3. Use the UP/DOWN buttons to select desired start address.
4. Press the ENTER button to confirm the choice.

Note: After switching on, the ArcPadXtreme will automatically detect whether DMX 512 data is received or not. If there is no data received at the DMX input, the display will start to flash “A001” with actually set address.

6.2 Fixture information



Use this menu to read useful information about the fixture status.

To display desired information.

1. Use the UP/DOWN buttons to find the “ InFo ” menu.
2. Press the ENTER button.
3. Use the UP/DOWN buttons to select the required menu item.
4. Press the ENTER button to confirm the choice.

Po.ti. --- **Power On Time.** Use the menu item to read the number of operation hours for each LEDs operating mode.

totL - the function shows the total number of the operation hours since the ArcPad Xtreme has been fabricated.

rSEt - the function shows the number of the operation hours that the ArcPad Xtreme has been powered on since the counter was last reset. In order to reset this counter to 0 you have to press and hold the UP and DOWN buttons and at the same time press the ENTER button.

DM.In.---**DMX values.** Select this function to read DMX values of each channel received by the fixture.

tEMP --- **Fixture Temperatures.** Select this menu to read the temperatures of the fixture:

Cur.t. --- the current temperature of the fixture inside.

Hi.tE. - the menu item shows the max. temperatures of the fixture inside since the ArcPad Xtreme has been fabricated.

rSEt --- the menu item shows the maximum temperatures of the fixture inside since the counter was last reset. In order to reset this counter to 0 you have to press and hold the UP and DOWN buttons and at the same time press the ENTER button.

Note: The ambient temperature should not exceed 40°C.

Measuring points:

LEdS.--- the temperature of the LEDs module.

boAr. --- the temperature on the PCB in the fixture head.

The temperatures can be displayed in either °C or °F units - see option "tEM.U" in the menu "Pers".

VErS. ---**Software Versions.** Select this function to read the software versions of the fixture processors.

IC1 --- the processor controls LEDs module

IC2 --- EEprom

6.3 Personality



Use this menu to modify the ArcPad Xtreme operating behaviour.

DM.Pr. --- **DMX preset.** Select this menu item to set a desired DMX mode. Please refer to the chapter "DMX protocol" for detail description of each DMX mode.

DiSP. --- **Display adjusting.** This function allows you to change the display settings.

d.On --- this function allows you to keep the display on or to turn off automatically 2 minutes after last pressing any button on the control panel.

d.Int. --- select this function to adjust the display intensity (20-min.,100-max.).

turn --- select this function to turn the display by 180°.

tEM.U. --- **Temperature Unit.** Use this menu in order to display the fixture temperatures in desired units: °C or °F.

bALA --- **Balance***. Use this menu item to enable (On) or disable (Off) the white balance which is set in the "White colour balance" menu below. If this function is set off, the will use maximum values (255) of saturation for red, green and blue colour. This function has to be set on before adjusting a white balance.

C.bAL. --- **White Colour Balance***. The menu gives access to the setting of the white balance.

To set the white colour balance.

1. Use a DMX controller or the " Man.C." menu to set all LEDs on max. saturation.
2. Use the UP/DOWN buttons to find the " Pers." menu.
3. Press the ENTER button.
4. Use the UP/DOWN buttons to select the "C.bAL" menu.
5. Press the ENTER button and the "rEd" item will appear on the display.
6. Press the ENTER button and use the UP/DOWN buttons to set new max. value for the red LEDs.

7. Press the ENTER button to confirm the choice.
8. Use the UP/DOWN buttons to select next colour, the “GrEn”.
9. Repeat steps 6-7 for this channel.
10. Use the UP/DOWN buttons to select the last colour, the „bLuE“ and repeat steps 6-7 for this colour.
*RGBW version only

LoAd --- **Load of LEDs.** The menu allows to choose 2 operating modes for fixture.

FuLL --- Maximum light output.

EcO. --- The light output is decreased by 25%.

In.Po. --- **Init effect positions.** Use this function to set all effects to the desired positions to which they will move after switching the fixture on (if DMX is not being received).

Note. If DMX mode 1 is selected, only values set at items “MACr” (macro) and dinr (dimmer) will be accepted.

dF.SE. --- **Default Settings .**The menu item sets all fixture parameters to the default (factory) values.

6.4 Manual mode



Use this menu for control the fixture without connected DMX console.

PrE.C. --- Preset effects control. Select this menu to call up preset positions of the channel effects.

Man.C. --- Manual effect control. Select this menu to control all channels via buttons of the control board.

To control fixture channels.

1. Use the UP/DOWN buttons to find “ Man.C“ menu.
2. Press the ENTER button.
3. Use the UP/DOWN buttons to select desired effect (channel).

List of control channels for RGBW version:

“rEd1” - “rEd2” - red LEDs saturations, LED modules 1 and 2

“GrE1” - “GrE2” - green LEDs saturations, LED modules 1 and 2

“bLu1” - “bLu2” - blue LEDs saturations, LED modules 1 and 2

“Whi1” - “Whi2” white LEDs saturations, LED modules 1 and 2

“MACr” - colour macros

“Stro.” - a strobe, shutter

“dimr” - a dimmer

List of control channels for SW version:

“Uhi1” - “Uhi3” – warm white LEDs saturation, LED modules 1 and 2

“Uhi2” - “Uhi4”- cool white/neutral white LEDs saturations, LED modules 1 and 2

“Stro.” - a strobe, shutter

“dimr” - a dimmer

List of control channels:

“COL.1” - LEDs saturation-module 1

“COL.2” - LEDs saturation-module 2

“Stro.” - a strobe, shutter

“dimr” - a dimmer

“F.dim” a fine dimmer

4. Press the ENTER button and use the UP/DOWN buttons to set value , press the ENTER button to confirm it.

6.5 Test sequences



Use this menu to run demo-test sequences without an external controller, which will show you some possibilities of using the ArcPad Xtreme.

6.6 Stand-alone setting



The fixtures on a data link are not connected to the controller but can execute pre-set programs which can be different for every fixture. "Stand-alone operation" can be applied to the single fixture or to multiple fixtures operating synchronously.

Synchronous operation of multiple fixtures requires that they must be connected on a data link and one of them is set as a master ("MASt") and the rest as the slaves ("SLA"). Up to 32 fixtures can be connected in a master/slave chain. Only one fixture can be set as the master. This option does not function at wireless operation.

Note: Disconnect the fixtures from the DMX controller before master/slave operating, otherwise data collisions can occur and the fixtures will not work properly. See the chapters "Stand-alone operation" and "Master/slave connection".

Auto. --- Automatic playback. This function allows you to select the program which will be played after switching the fixture on. Selected program will be played continuously in a loop.

1. Use the UP/DOWN buttons to find "St.AL." menu.
2. Press the ENTER button.
3. Use the UP/DOWN buttons to select "Auto" item.
4. Press the ENTER button.
5. Use the UP/DOWN buttons to select desired program.
6. Press the ENTER button to confirm the choice.

PLAY --- Playing program. By enter to this menu a complete overview of all programs is offered, from which the program to be run can be selected.

1. Use the UP/DOWN buttons to find "St.AL." menu.
2. Press the ENTER button.
3. Use the UP/DOWN buttons to select desired program.
4. Press the ENTER button. The selected program runs in a loop.

Edit --- Editing a program. The fixture offers 3 editable programs (EPG.1-EPG.3) each up to 68 steps. Every program step includes a fade time-the time taken by the step's channel status to reach the desired level and a step time-the total time occupied by the step in the program.

E.g. If "F.tim."=5 second and "S.tim."=20 second, effects will go to the desired position during 5 seconds and after that they will stay in this position for 15 seconds before going to the next prog. step

1. Use the UP/DOWN buttons to find "St.AL." menu and press the ENTER button.
2. Use the UP/DOWN buttons to select "Edit" menu and press the ENTER button.
3. Use the UP/DOWN buttons to select a program you want to edit (PrG.1-PrG.3 and press ENTER button.
4. Use the UP/DOWN buttons to select a desired program step ("St.01" - "St.68") and press ENTER button.
5. Use the UP/DOWN buttons to select a channel you want to edit and press the ENTER button.
6. There are special items in the list of control channels:
 - "P.End" - a total number of the program steps (value 1-68). This value should be set before start Programming (e.g. if you want to create program with 10 steps, set P.End=10).
 - "F.tim." - a fade time, (0-25.5) seconds
 - "S.tim." - step time, value (0-25.5) seconds
 - "COPY" - this item duplicates the current prog. step to the next prog. step. The item "P.End" is increased automatically.
7. Use the UP/DOWN buttons to set a DMX value of the channel and then press the ENTER button.
8. Use the UP/DOWN buttons to select next channel and press the ENTER button.
9. After having set all channels in the current program step, press the MODE button to go by one menu level back and select another program step.

6.7 Special functions



rdML --- **Code.** This menu item shows the first part of the RDM identification code.

rdMH --- **Code.** This menu item shows the second part of the RDM identification code.

rAdI --- **Wireless DMX.** The menu serves for reading of the wireless operation status.

r.InF. --- **Wireless DMX information.** The menu item shows level of received signal in %. If the fixture is not linked to the transmitter, “no.LI” is displayed.

r.UnL. --- **Wireless DMX unlink.** The item serves for unlinking the fixture from transmitter.

Adj --- **Effect Adjustment.** The menu allows calibration of each LEDs array.

dMH --- **DMX Values.** The menu item enables to control all LEDs before calibrating each LEDs array.

CAL.U --- **Calibrating unit.** The menu serves for fine current calibration of LEDs during fixture burn-in at a factory. Each LED array can be calibrated separately. Users should not change the setting.

Hold --- **Hold DMX.** If the function is on, the last received DMX values are held in case, that DMX data receiving was interrupted (e.g. disconnected DMX controller).

uPd.M. --- **Updating mode.** The menu item allows you to update software in the fixture.

7. RDM

This fixture is ready for RDM operation. RDM (Remote Device Management) is a bi-directional communications protocol for use in DMX512 control systems, it is the new open standard for DMX512 device configuration and status monitoring.

The RDM protocol allows data packets to be inserted into a DMX512 data stream without adversely affecting existing non-RDM equipment. By using a special „Start Code,“ and by complying with the timing specifications for DMX512, the RDM protocol allows a console or dedicated RDM controller to send commands to and receive messages from specific moving lights.

RDM allows explicit commands to be sent to a device and responses to be received from it.

The list of commands for ArcPad Xtreme is the following.

Parameter ID	Discovery command	SET command	GET command
DISC_UNIQUE_BRANCH	*		
DISC_MUTE	*		
DISC_UN_MUTE	*		
DEVICE_INFO			*
SUPPORTED_PARAMETERS			*
SOFTWARE_VERSION_LABEL			*
DMX_START_ADDRESS		*	*
IDENTIFY_DEVICE		*	*
DEVICE_MODEL_DESCRIPTION			*

ArcPad Xtreme/W (Wireless DMX version)

MANUFACTURER_LABEL			*
DEVICE_LABEL		*	*
SENSOR_DEFINITION			*
SENSOR_VALUE			*
DISPLAY_LEVEL		*	*
DEVICE_RESET		*	
DMX_PERSONALITY		*	*
DMX_PERSONALITY_DESCRIPTION			*
STATUS_MESSAGES			*
STATUS_ID_DESCRIPTION			*
DEVICE_HOURS			*

8. Error and information messages

t.M.Er.(Temperature measuring error)

The message informs you that the LED module temperature sensor is defective.

MA.Er. (Master error)

The fixture is set as a master and DMX signal is connected to the fixture.

9. Technical specifications

Power supply

- Electronic auto-ranging
- Input voltage: 100 - 250V AC, 50-60 Hz
- Power consumption

Power mode	Max. power consumption (All LED channels at full)	Typical power consumption (2 LED Channels at full)	Ambient Temperature
Full mode	580W (590VA)	310W	25°C
Eco mode	300W (320VA)	160W	

- Fuse: F12A

Optic & Effects

- Light source (RGBW ver.): 188 ProLight Opto 3 Watt Proeon LEDs (56 red, 44 green, 44 blue, 44 white)
(SW ver.): 188 ProLight Opto 3 Watt Proeon LEDs (Warm white+ Cool white or Neutral White)
(SC ver.): 188 ProLight Opto 3 Watt Proeon LEDs
- Available optical system: 10°, 23°, 44°, 14°x26°
- RGBW colour mixing (RGBW version)
- Built-in colour macros (RGBW version)
- Adjustable strobe sequences
- White colour balance adjusting (RGBW version)
- Lumen maintenance:

Channels @ full intensity	Power mode	L ₇₀
One LED channel	Full mode	95,000
	Eco mode	108,000
Two LED channels	Full mode	90,000
	Eco mode	102,000
Three LED channels	Full mode	84,000
	Eco mode	95,000
All LED channels	Full mode	77,000
	Eco mode	88,000

L₇₀ = 70% maintenance of initial lumen output in hours

Control

- Control: USITT DMX 512 (RDM support)
- Control options: DMX, RDM
- Operations modes: DMX, Stand-alone
- DMX protocol modes: 6 (2,3,4,8,12 control channels-RGBW version)
4 (2,2,5, control channels-SW version)
4 (1,3,2,5 control channels –SC version)
- Manual control of all effects via RUNIT WTX
- 3 user editable programs each up to 68 steps

Wireless DMX/RDM module

- Compliance with USITT DMX-512 (1986 & 1990) and 512-A
- Full DMX fidelity and frame integrity
- Auto sensing of DMX frame rate and frame size
- <5ms DMX latency
- Operational frequency range of 2402-2480 MHz
- Producer: LumenRadio

Antenna

- Max. gain: 5dBi

ArcPad Xtreme/W (Wireless DMX version)

Strobe

- Strobe effect with variable speed (max. 20 flashes per second)
- Pre-programmed random strobe pulse-effects

Dimmer

- Smooth 16-bit dimming from 0 - 100 %

Power supply

- Power cable

Rigging

- Via mounting bracket

Temperatures

- Maximum ambient temperature: 40° C
- Maximum housing temperature: 85° C

Housing

- Cast aluminium

Dimensions (mm)

ArcPad Xtreme

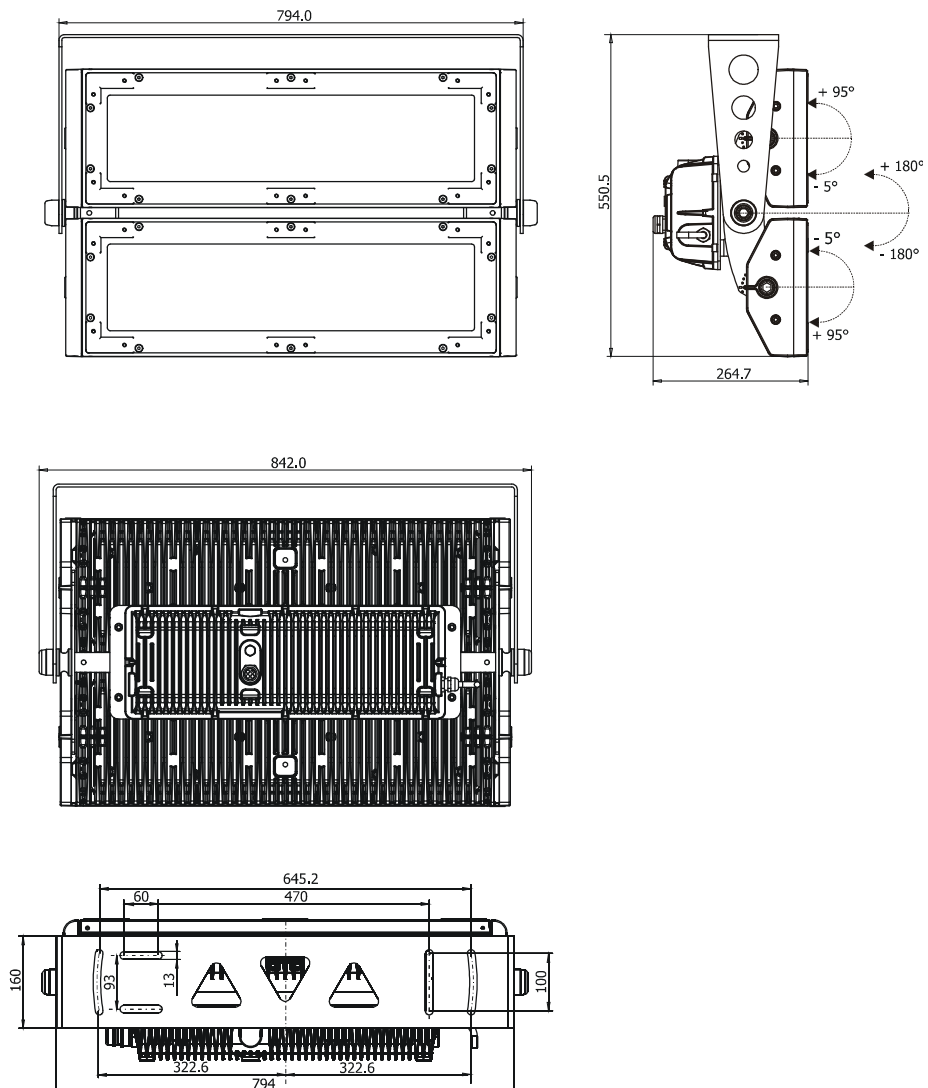

Junction box

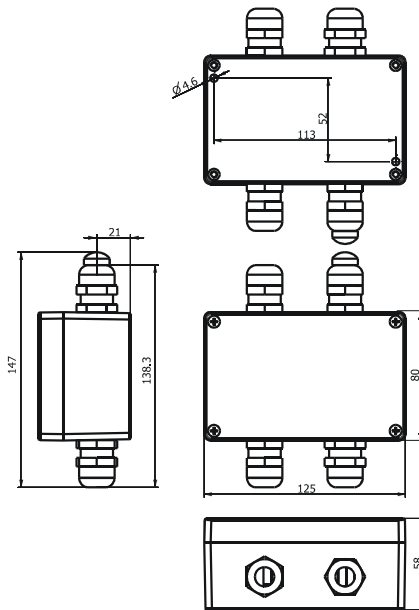

Weight

- 57 kg

Protection factor

- IP 67

Connection

- Data/power cable
- junction box

Included items

- 1 x ArcPad Xtreme
- 1 x Junction box (P/N 99712992)
- 1 x User manual
- 1 x Gasket of cable grommet M20, PF ½ (P/N 1305 1388)

Optional accessories

- Barn-doors in silver colour (P/N 10980081)
- Top hat in silver colour (P/N 10980087)
- Half top hat in silver colour (P/N 10980088)

10. Cleaning and maintenance

DANGER !
Disconnect from the mains before starting any cleaning or maintenance work

Rinse off loose dirt with a garden hose or low pressure water spray. Wash the housing with a soft brush or sponge and a mild, non-abrasive washing detergent. Rinse it.

There are no serviceable parts inside the device.

Maintenance and service operations are only to be carried out by a qualified person.

Should you need any spare parts, please use genuine parts.

If the power supply cable of this device will be damaged (cable firmly connected with the device), it has to be replaced by authorized distributors only in order to avoid hazards.

11. Appendix

11.1 ArcPad Xtreme EPS

Besides the ArcPad Xtreme exists variant with separated LED modules and control unit, which is named the ArcPad Xtreme EPS. Its differences compared to the ArcPad Xtreme are described below. Control ans setting is the same as at the compact version.

Fixture exterior view

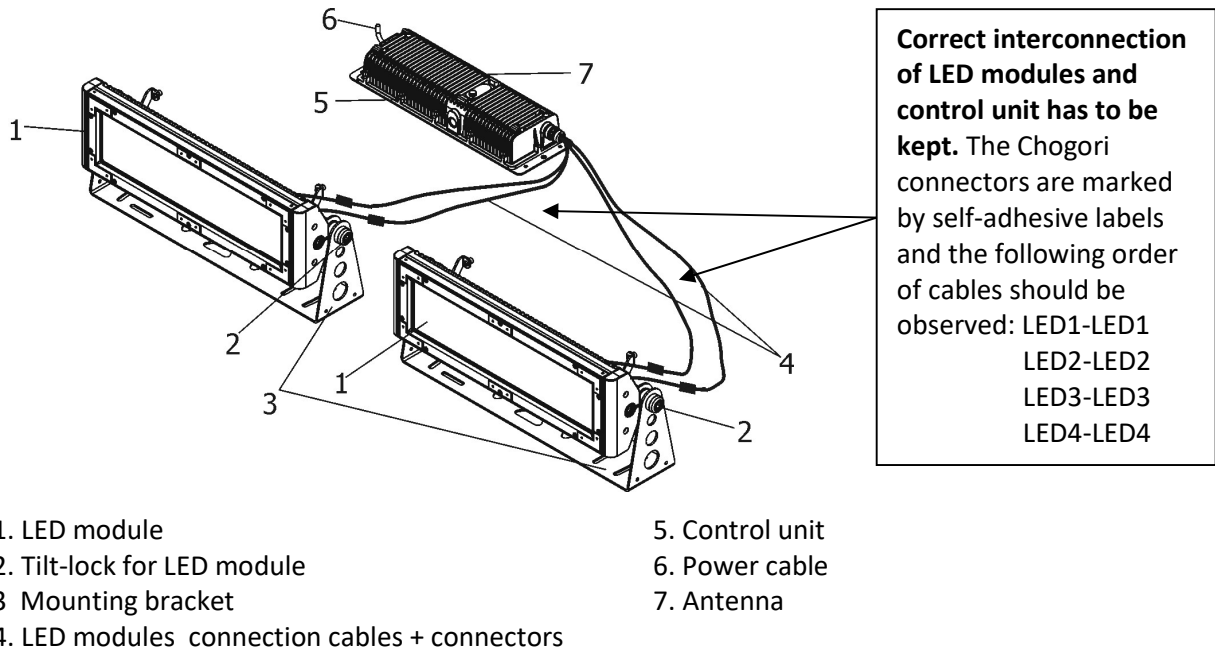

Connection between LED modules and control unit

Four pairs of the Igus CF9.03.08 cables serve for interconnection of the LED modules and the control unit. The Chogori connectors are marked by self-adhesive labels (LED1, LED2, LED3, LED4) next to the connectors and the following order of cable connections has to be kept to ensure correct operation of the fixture:

LED1-LED1
LED2-LED2
LED3-LED3
LED4-LED4

Wiring of the Chogori connectors:

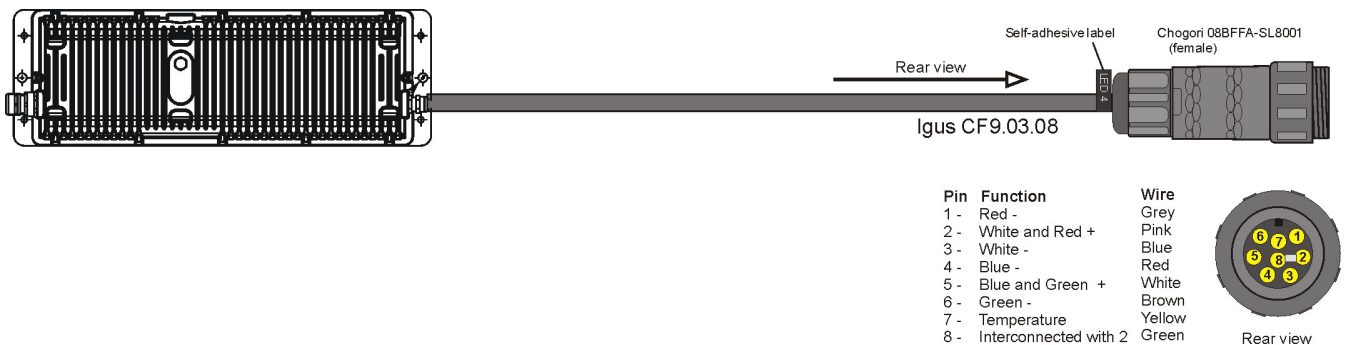

ArcPad Xtreme/W (Wireless DMX version)

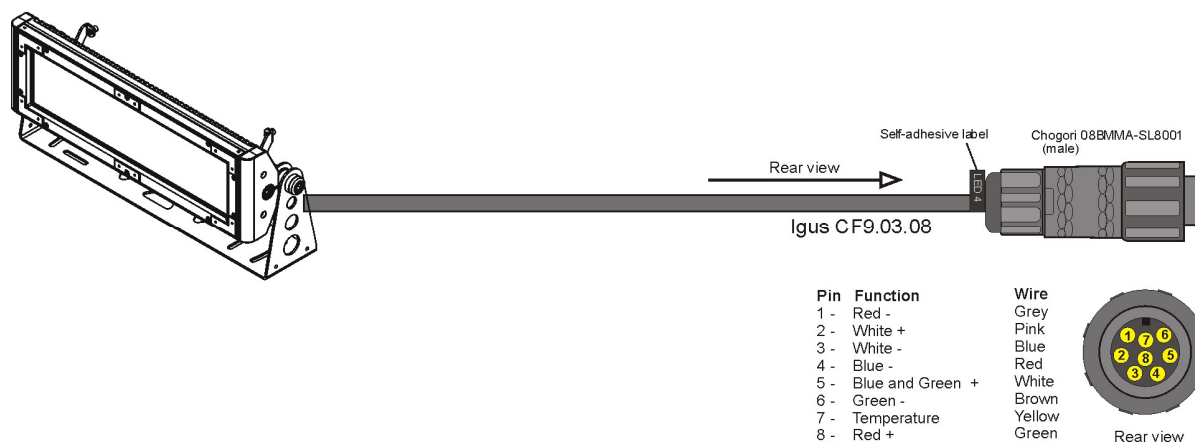

Standard cables allow max. distance between LED module and control unit cca 0.7m. For longer distance you have to use adapter cables wired 1:1.

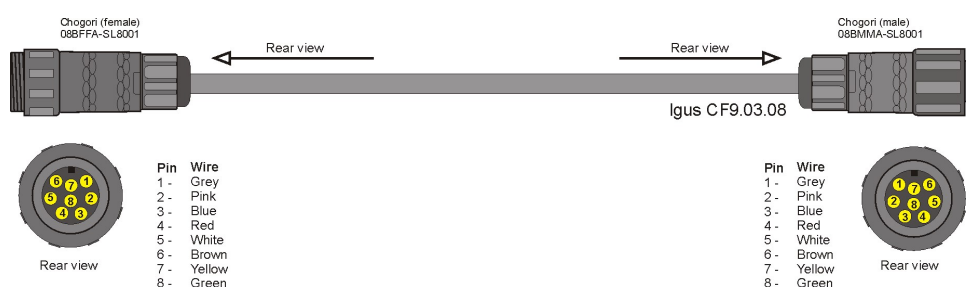

Max. length between LED module and control unit must not exceed 20m.

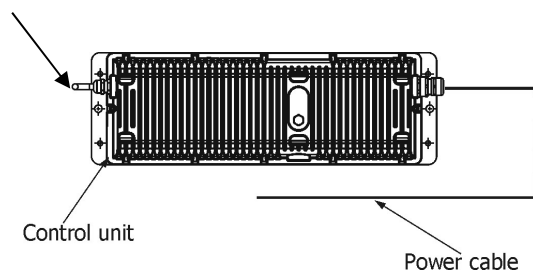

If the LED modules and the base are installed separately on the metal structure (LED modules and the base are galvanic interconnected), the LED modules fall under protection class I and must be grounded in accordance with all national and local electrical and construction regulations.

In case that LED modules and the base are installed separately on the insulant e.g. wall (LED modules and the base are not galvanic interconnected), the LED modules fall under protection class 3 and do not need to be grounded.

Cables

- LED modules connection: cable: Igus CF9.03.08
connectors: 4x Chogori 08BFFA-SL8001; 4x Chogori 08BMM-SL8001

NOTE: max. length between LED module and control unit: 20m

ArcPad Xtreme/W (Wireless DMX version)

Dimensions (mm)

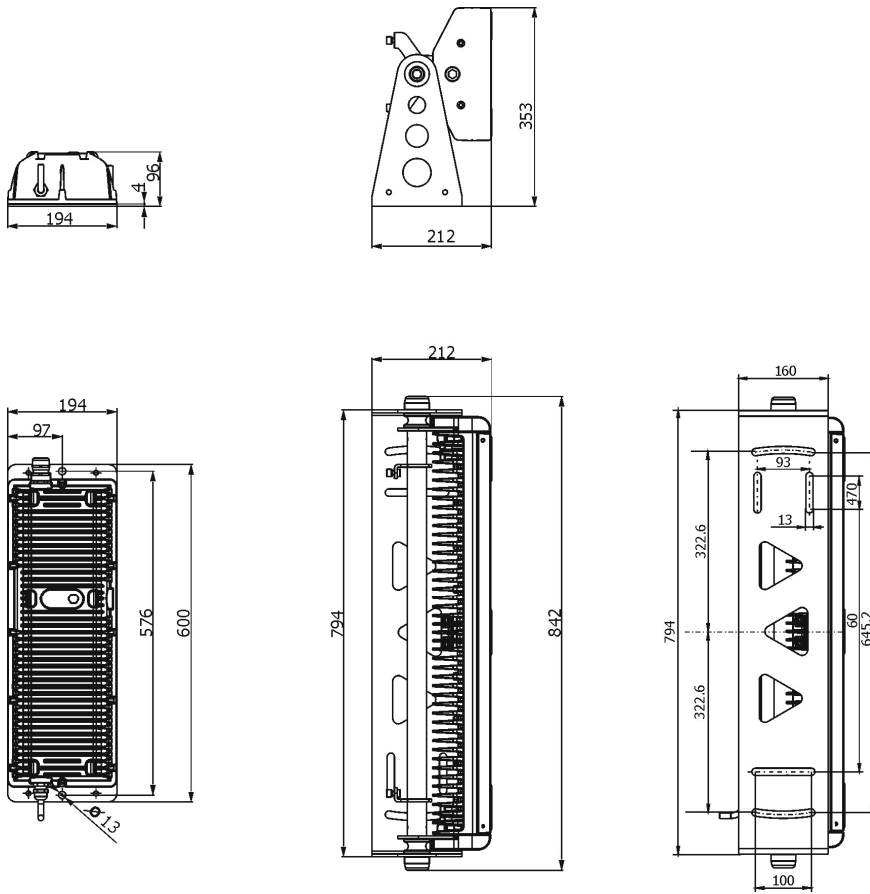

Weight

LED module with mounting bracket: 24 kg
Control unit: 9 kg

Specifications are subject to change without notice.

January 17, 2017

ArcPad Xtreme/W (Wireless DMX version)