

ArcPower Unit

Rack Mount
Rack Mount US
Rack Mount US LV

Wall Mount
Wall Mount US
Wall Mount US LV

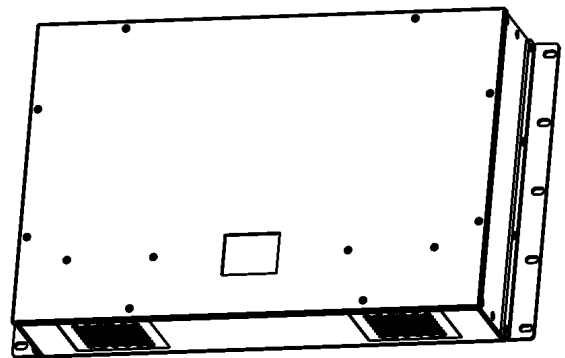
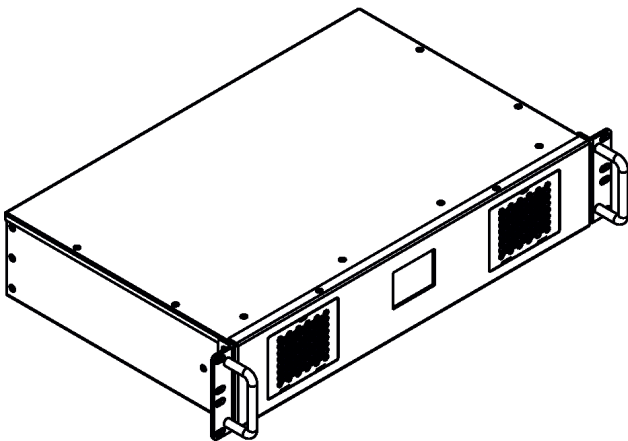

ArcPower Unit

Table of contents

1. Important safety instructions	3
2. Operating determinations	3
3. Description of the ArcPower Unit	5
4. Configuration of terminals	6
5. Installation	6
5.1 Connection to mains	6
5.2 Mounting the ArcPower Unit	8
5.3. DMX 512 operation	9
6. Global and zone effects	10
7. Fixture menu	15
7.1 Configuration	15
7.2 Information	21
7.3 Personality	23
7.4 Manual mode	24
7.5 Stand-alone setting	25
7.6 Special Functions	27
8. Diagnostic query	29
9. Technical Specifications	31
10. Maintenance	34
10.1 Replacing the air filters	34
10.2 Replacing the main fuse	35
10.3 Disposing of the product	35
11. ChangeLog	35

CAUTION!
Unplug mains lead before opening the housing!

**FOR YOUR OWN SAFETY, PLEASE READ THIS USER MANUAL CAREFULLY
BEFORE YOU INITIAL START - UP!**

1. Important safety instructions

Every person involved with installation and maintenance of this product has to:

- be qualified
- **follow all instructions and heed all warnings in this manual.**

CAUTION!
Be careful with your operations. With a high voltage you can suffer a dangerous electric shock when touching the wires inside the unit!

This product has left our premises in absolutely perfect condition. In order to maintain this condition and to ensure a safe operation, it is absolutely necessary for the user to follow the safety instructions and warning notes written in this manual.

WARNING
To prevent injury, this device must be securely attached to a rack in accordance with the installation instructions.

Do not block any ventilation openings. Install in accordance with the manufacturer's instructions.

Do not install near any heat sources such as radiators or other devices that produce heat.

Do not use this device near water. Clean only with dry cloth.

Only use attachments/accessories specified by the manufacturer.

Refer all servicing to qualified service personnel. Servicing is required when the device has been damaged in any way, such as power supply cord or plug is damaged, liquid has been spilled or objects have fallen into the device, the device has been exposed to rain or moisture, does not operate normally, or has been dropped.

Use a source of AC power that complies with local building and electrical rules. AC power has to have both overload and short circuit protection.

This device falls under protection class I. Therefore the ArcPower Unit has to be connected to a mains socket outlet with a protective earthing connection!

2. Operating determinations

This product was designed for indoor use only.

If the unit has been exposed to drastic temperature fluctuation (e.g. after transportation), do not switch it on immediately. The arising condensation water might damage your unit. Leave the unit switched off until it has reached room temperature.

Avoid brute force when installing or operating the unit.

When choosing the installation spot, please make sure that the unit is not exposed to extreme heat, moisture or dust.

Only operate the unit after having checked that the housing is firmly closed and all screws are tightly fastened. The maximum ambient temperature 50° C must never be exceeded.

Operate the unit only after having familiarized with its functions. Do not permit operation by persons not qualified for operating the unit. Most damages are the result of unprofessional operation!

Please use the original packaging if the product is to be transported.

Please consider that unauthorized modifications on the unit are forbidden due to safety reasons!

Warning: Operation of this equipment in a residential environment could cause radio interference.

Resistance of the equipment is designed for electromagnetic environments E1, E2, E3 according to the standard EN55103-2 ed.2 Electromagnetic compatibility. Product family standard for audio, video, audiovisual and entertainment lighting control apparatus for professional use. Part 2: Immunity. The product (covers and cables) must not be exposed to a high frequency electromagnetic field higher than 3V/m.

The installation company should measure levels of possible interferences above the tested levels E1,E2,E3 given by this standard (e.g. transmitters in surrounding area) before installing the equipment.

Emission of the equipment complies with the standard EN55032 Electromagnetic compatibility of multimedia equipment – Emission Requirements according to class A.

3. Description of the ArcPower Unit

The ArcPower Unit is designed in two variants:

The ArcPower Unit Rack Mount (ArcPower Unit Rack Mount US, ArcPower Unit Rack Mount US LV) is intended for mounting into 19-inch equipment rack.

The ArcPower Unit Wall Mount (ArcPower Unit Wal Mount US, ArcPower Unit Wall Mount US LV) is intended for mounting on the wall.

ArcPower Unit Rack Mount

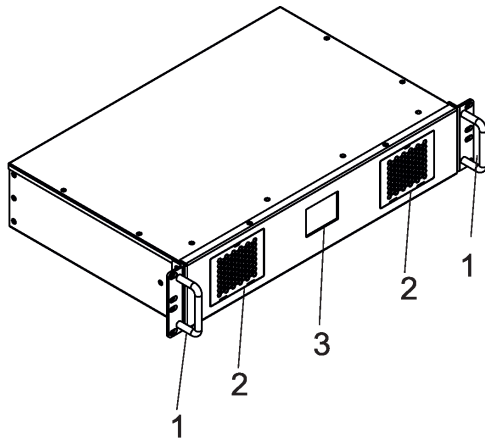

- 1 - Handles
- 2 - Air filter holders
- 3 - graphic touch screen

ArcPower Unit Wall Mount

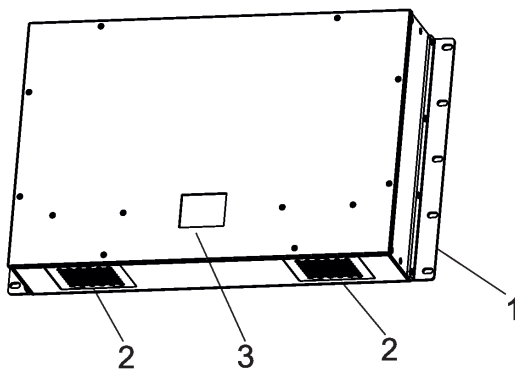

- 1 - Mounting holder
- 2 - Air filter holders
- 3 - graphic touch screen

Rear panel

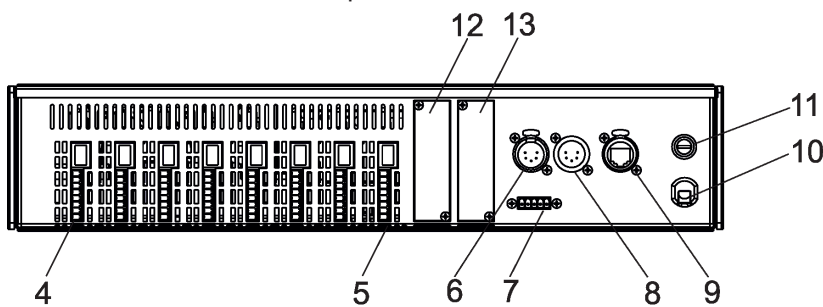

- 4 - LED zone 1 output
- 5 - LED zone 8 output
- 6 - LED pixel zone 6 output (US LV version only)
- 6 - DMX OUT (5-pin XLR)
- 7 - Input for trigger and 12V output
- 8 - DMX IN (5-pin XLR)
- 9 - Ethernet (RJ45)
- 10 - Mains input
- 11 - Fuse holder
- 12,13 - Free slots for optional zones (e.g. Fan zone, Real Time Zone, 0-10V Zone)

Rear panel (US LV version only)

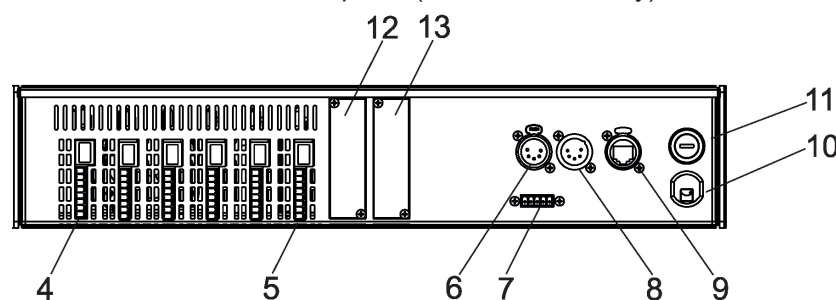

4. Configuration of terminals

DMX In/Out
(XLR mounting sockets)

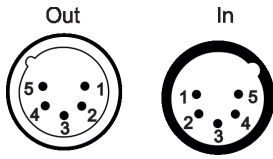

Pin 1: Shield
Pin 2: Signal (-)
Pin 3: Signal (+)
Pin 4: Not connected
Pin 5: Not connected

Ethernet
(RJ 45 female)

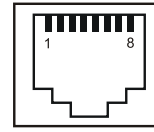

Pin 1: TX+
Pin 2: TX-
Pin 3: RX+
Pin 4: Not connected
Pin 5: Not connected
Pin 6: RX-
Pin 7: Not connected
Pin 8: Not connected

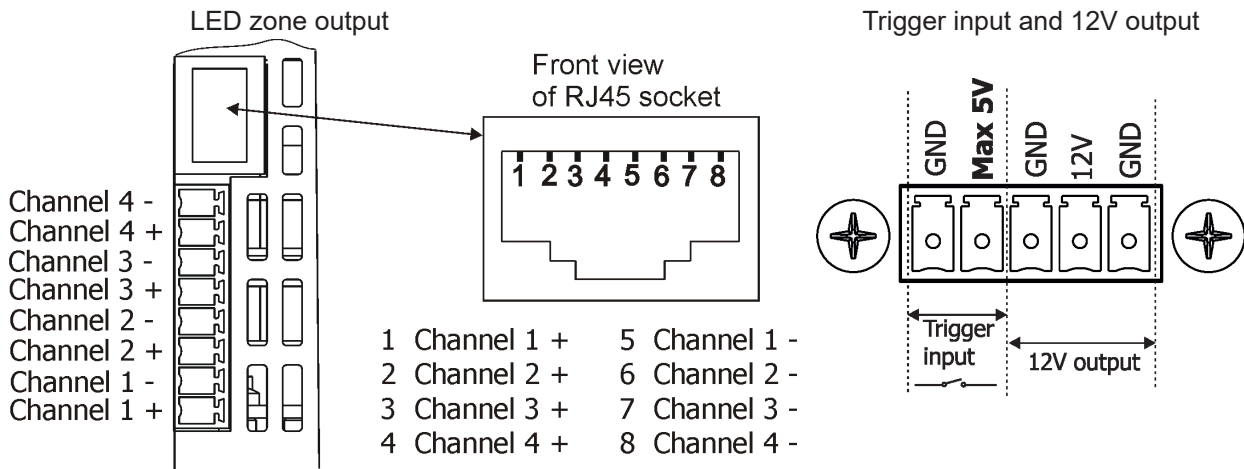

5. Installation

5.1 Connection to mains

CAUTION!

The ArcPower Unit must be installed by a qualified electrician in accordance with all national and local electrical and construction codes and regulations.

These servicing instructions are for use by qualified service personnel only. To reduce the risk of electric shock do not perform any servicing other than that contained in the operating instructions unless you are qualified to do so.

This device falls under protection class I. Therefore the ArcPower Unit has to be connected to a mains socket outlet with a protective earthing connection.

The ArcPower Unit Rack Mount (ArcPower Unit Wall Mount) is equipped with auto-switching power supply that automatically adjusts to any 50-60Hz AC power source from 100-240 Volts. Connect the fixture to the mains by means of inbuilt power cord.

The ArcPower Unit Rack Mount US (ArcPower Unit Rack Mount US) and the ArcPower Unit Rack Mount US LV (ArcPower Unit Rack Mount US LV) are equipped with auto-switching power supply that automatically adjusts to any 50-60Hz AC power source from 100-277 Volts. Connect the fixture to the mains by means of

inbuilt power cord.

If you need to install a cord plug on the power cord to allow connection to power outlets, install a grounding-type (earthed) plug, following the plug manufacturer's instructions. If you have any doubts about proper installation, consult a qualified electrician.

Core (EU)	Core (US)	Connection	Plug Terminal Marking
Brown	Black	Live	L
Light blue	White	Neutral	N
Green /Yellow	Green	Earth	

This device falls under class one and must be earthed (grounded).
Wiring and connection work must be carried out by qualified staff.

5.2 Mounting the ArcPower Unit

ArcPower Unit Rack Mount

The ArcPower Unit Rack Mount is designed for mounting into 19-inch equipment rack. Fasten the ArcPower Unit Rack Mount into rack by means of two screws on each side of the ArcPower Unit Rack Mount .

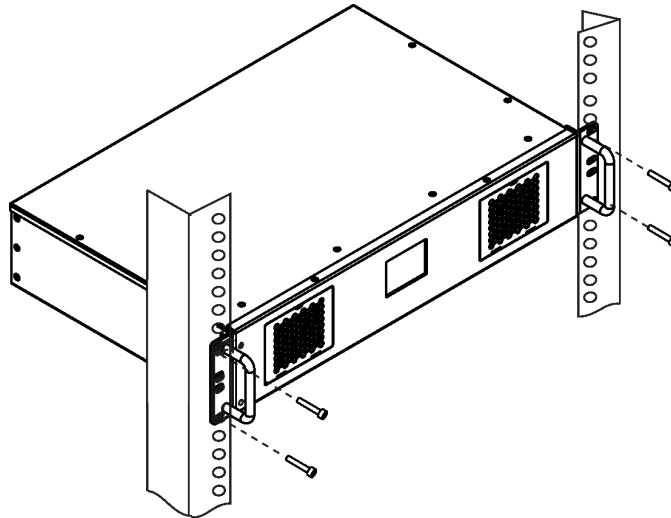

ArcPower Unit Wall Mount

The ArcPower Unit Wall Mount is designed for mounting on the wall. Fasten the ArcPower Unit Wall Mount on a non-flammable flat wall by means of screws (use two screws at least on each side of the ArcPower Unit Wall Mount).

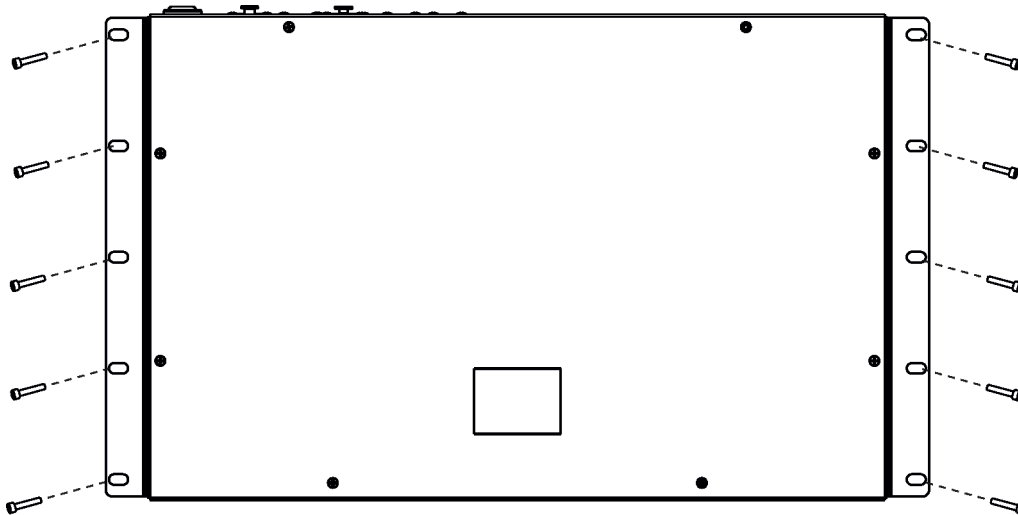

Multiple device mounting

If you install more than one piece of the ArcPower Unit Wall Mount, install them side by side, do not install them below each other (and do not install the ArcPower Unit Wall mount above some heat source) because the ArcPower Unit has suction fans on the front panel.

Correct mounting:

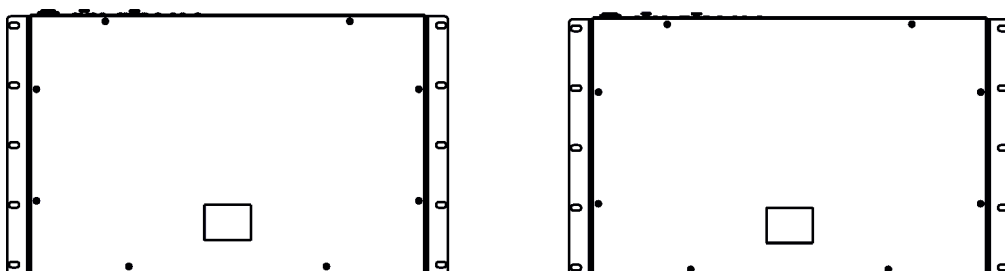

Incorrect mounting:

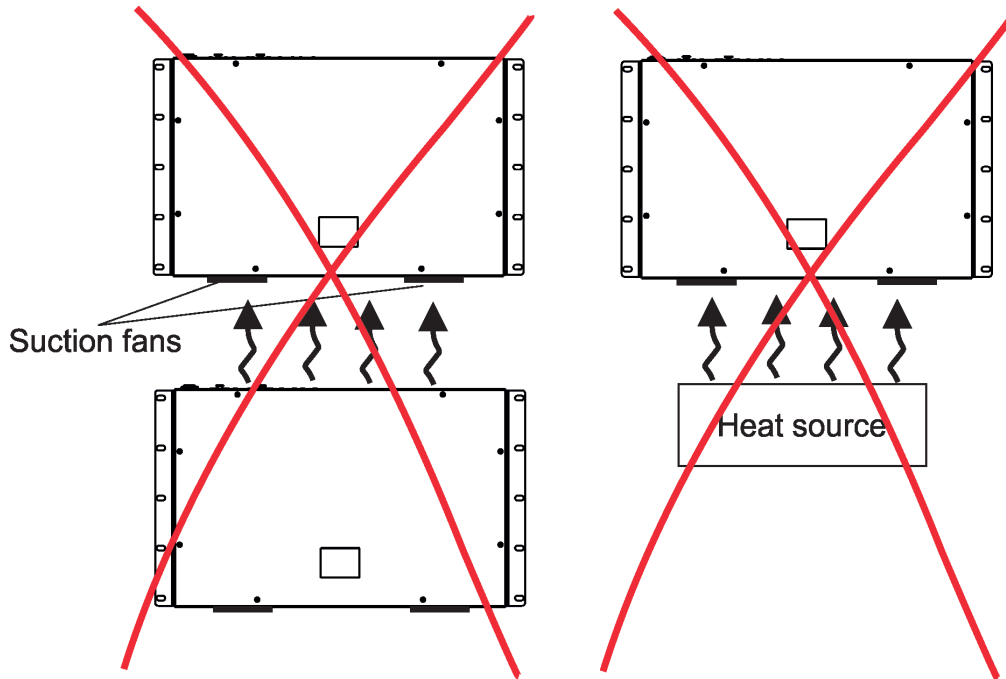

5.3. DMX 512 operation

The ArcPower Unit is equipped with 5-pin XLR sockets for DMX input and output. Only use a shielded twisted-pair cable designed for RS-485 and 5-pin XLR connectors in order to connect the fixture with the DMX controller or one fixture with another.

To build a DMX chain.

1. Unplug ArcPower Units from the mains before installation.
2. Connect the LED modules to the ArcPower Units .
3. Connect ArcPower Units each other. Max. 32 fixtures may be connected on a DMX link.
Terminate the DMX link by installing a termination plug in the output of the last fixture.
The termination plug is a male 5-pin XLR plug with a 120 Ohm resistor soldered between Signal (-) and Signal (+).
4. Connect ArcPower Units to mains.
5. Set each ArcPower Unit.
6. Connect the DMX controller to the first fixture.

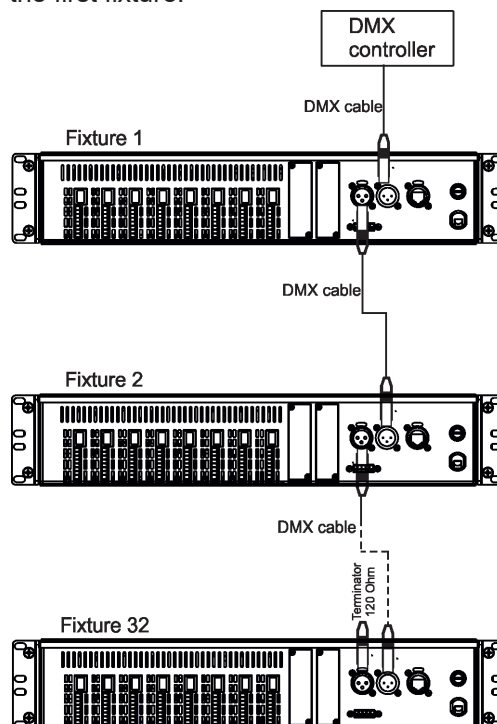

6. Global and zone effects

The ArcPower Unit uses two types of effects: global and local.

The global effects have priority to the local effects (= effects of LED modules at each zone).

The global effects always use the first 4 DMX channels from used DMX range (which begins by DMX address).

The global effects go for all LED modules on all zones.

Global effects (non-pixel module only)

The effects are used in DMX mode 1, 2 and 3.

List of global effects (if DMX address=1)

Used channel	Effect
1	Colour Macro
2	Strobe
3	Dimmer
4	Dimmer fine

Example: DMX address=1, channels 1-4 are used for global effects

DMX address =55, channels 55-58 are used for global effects

You cannot change the order of the effect assignment to DMX channels 1-4 (55-58) and this assignment goes for DMX modes 1, 2 and 3 and all type of LED modules, no matter if all the effects are included in these types of LED modules.

Local effects (non-pixel module only)

The list of local effects depends on selected DMX mode and used LED modules. These effects are not used for pixel control.

Mode 1 (Fixed order) - default

In this mode zones are controlled together, order of channels cannot be changed. Global effects are used.

RGBW module	RGB module	SW module	Single C. module	White module
Red	Red	Warm white	Colour	White
Red Fine	Red Fine	Warm white Fine	Colour Fine	White Fine
Green	Green	Cool white		
Green Fine	Green Fine	Cool white Fine		
Blue	Blue			
Blue Fine	Blue Fine			
White				
White Fine				

Custom (number of channels can be set)

CH1 (Channel 1)
 CH1F (Channel 1 Fine)
 CH2 (Channel 2)
 CH2F (Channel 2 Fine)
 CH3 (Channel 3)
 CH3F (Channel 3 Fine)
 CH4 (Channel 4)
 CH4F (Channel 4 Fine)

Mode 2 (8-bit)

Each zone can be controlled separately in 8-bit mode. Global effects are used.

RGBW module	RGB module	SW module	Single C. module	White module
Red	Red	Warm white	Colour	White
Green	Green	Cool white	Dimmer	Dimmer
Blue	Blue	Dimmer		
White	Dimmer	Colour macro (whites)		
Dimmer	Colour macro			
Colour macro				

Custom (number of channels can be set)

CH1 (Channel 1)
 CH2 (Channel 2)
 CH3 (Channel 3)
 CH4 (Channel 4)
 Dimmer

Mode 3 (16-bit)

Each zone can be controlled separately in 16-bit mode. Global effects are used.

RGBW module	RGB module	SW module	Single C. module	White module
Red	Red	Warm white	Colour	White
Red Fine	Red Fine	Warm white Fine	Colour Fine	White Fine
Green	Green	Cool white	Dimmer	Dimmer
Green Fine	Green Fine	Cool white Fine	Dimmer Fine	Dimmer Fine
Blue	Blue	Dimmer		
Blue Fine	Blue Fine	Dimmer Fine		
White	Dimmer	Colour macro (whites)		
White Fine	Dimmer Fine			
Dimmer	Colour macro			
Dimmer Fine				
Colour macro				

Custom (number of channels can be set)

CH1 (Channel 1)
CH1 Fine (Channel 1 fine)
CH2 (Channel 2)
CH2 Fine (Channel 2 fine)
CH3 (Channel 3)
CH3 Fine (Channel 3 fine)
CH4 (Channel 4)
CH4 Fine (Channel 4 fine)
Dimmer
Dimmer fine

Mode 4 (Fixed order - compatible with the ArcControl 1)

In this mode zones are controlled together, order of channels cannot be changed. DMX address is automatically set at 1 (but can be changed).

This mode does not use global effects.

RGBW module	RGB module	SW module	Single C. module	White module
Red	Red	Warm white	Colour	White
Green	Green	Cool white	Dimmer	Dimmer
Blue	Blue	Dimmer		
White	Dimmer			
Dimmer				

Mode 5 (8-bit without Global effects)

The mode 5 is similar to the Mode 2 but without colour macros, dimmer and Global effects. DMX address is automatically set at 1 (but can be changed)

RGBW module	RGB module	SW module	Single C. module	White module
Red	Red	Warm white	Colour	White
Green	Green	Cool white		
Blue	Blue			
White				

Custom (number of channels can be set)

CH1 (Channel 1)
CH2 (Channel 2)
CH3 (Channel 3)
CH4 (Channel 4)

Mode 6 (16-bit without Global effects)

The mode 6 is similar to the Mode 5, in addition the mode have fine channels. DMX address is automatically set at 1 (but can be changed). Global effects are not used.

RGBW module	RGB module	SW module	Single C. module	White module
Red	Red	Warm white	Colour	White
Red Fine	Red Fine	Warm white Fine	Colour Fine	White Fine
Green	Green	Cool white		
Green Fine	Green Fine	Cool white Fine		
Blue	Blue			
Blue Fine	Blue Fine			
White				
White Fine				

Custom (number of channels can be set)

CH1 (Channel 1)

CH1 Fine (Channel 1 fine)

CH2 (Channel 2)

CH2 Fine (Channel 2 fine)

CH3 (Channel 3)

CH3 Fine (Channel 3 fine)

CH4 (Channel 4)

CH4 Fine (Channel 4 fine)

DMX table for local and global effects

DMX Value	Local Effects	Type of control
0-255	Red Red LEDs saturation control (0-->100%)	proportional
0-255	Red Fine Red LEDs saturation control fine (min.-->max.)	proportional
0-255	Green Green LEDs saturation control (0-->100%)	proportional
0-255	Green Fine Green LEDs saturation control fine (min.-->max.)	proportional
0-255	Blue Blue LEDs saturation control (0-->100%)	proportional
0-255	Blue Fine Blue LEDs saturation control fine (min.-->max.)	proportional
0-255	White White LEDs saturation control (0-->100%)	proportional
0-255	White Fine White LEDs saturation control fine (min.-->max.)	proportional
0-255	Warm White Warm white LEDs saturation control (0-->100%)	proportional
0-255	Warm White Fine Warm white LEDs saturation control fine (min.-->max.)	proportional
0-255	Cool White Cool white LEDs saturation control (0-->100%)	proportional
0-255	Cool White Fine Cool white LEDs saturation control fine (min.-->max.)	proportional
0-255	Colour Single colour LEDs saturation control (0-->100%)	proportional
0-255	Colour Fine Single Colour LEDs saturation control fine (min.-->max.)	proportional
0-255	White White LEDs saturation control (0-->100%)	proportional
0-255	White Fine White LEDs saturation control fine (min.-->max.)	proportional
0-255	CH 1/2/3/4 (Channel 1/2/3/4) LEDs saturation control (0-->100%)	proportional
0-255	CH 1/2/3/4 Fine (Channel 1/2/3/4 fine) LEDs saturation control fine (min.-->max.)	proportional

DMX Value	Global Effects	Type of control
0-31	Strobe Shutter closed	step
32-63	Shutter open	step
64-95	Strobe-effect from slow to fast	proportional
96-127	Shutter open	step
128-143	Opening pulses in sequences from slow to fast	proportional
144-159	Closing pulses in sequences from fast to slow	proportional
160-191	Shutter open	step
192-223	Random strobe-effects from slow to fast	proportional
224-255	Shutter open	step
DMX Value	Local + Global Effects	Type of control
0-255	Dimmer Dimmer intensity (0-->100%)	proportional
0-255	Dimmer Fine Dimmer intensity fine (min.-->max.)	proportional
	Colour macro (RGB/RGBW modules)	
0	No function	step
1-15	Whites from warm -->cool	proportional
16	Blue (Blue=full, Red+Green+White=0)	step
17-55	Red=0, Green-->up, Blue =full, White=0	proportional
56	Light Blue (Red=0, Green=full, Blue =full, White=0)	step
57-95	Red=0, Green=full, Blue-->down, White=0	proportional
96	Green (Red=0, Green=full, Blue =0, White=0)	step
97-134	Red-->up, Green=full, Blue=0, White=0	proportional
135	Yellow-green (Red=full, Green=full, Blue=0, White=0)	step
136-174	Red=full, Green-->down, Blue=0, White=0	proportional
175	Red (Red=full, Green=0, Blue=0, White=0)	step
176-214	Red=full, Green=0, Blue-->up, White=0	proportional
215	Magenta (Red=full, Green=0, Blue=full, White=0)	step
216-254	Red-->down, Green=0, Blue=full, White=0	proportional
255	Blue (Red=0, Green=0, Blue=full, White=0)	step
	Colour macro (SW modules)	
0	Warm white=full, Cool White=0	step
1-127	Warm white=full, Cool white -->up	proportional
128	Warm white full, Cool White=full	step
129-254	Cool white=full, Warm white --> down	proportional
255	Cool white=full, Warm white=0	step

Example 1.

Order of DMX channels for 8 LED zone outputs for different LED modules (one LED module on each LED zone). Each LED zone is controlled separately.

DMX address=1, DMX mode 3 (16-bit)

DMX Channel	RGBW modules Effect	DMX Channel	SW modules Effect	DMX Channel	Single colour modules Effect
1	Colour macro (G)	1	Colour macro (G)	1	Colour macro* (G)
2	Strobe (G)	2	Strobe (G)	2	Strobe (G)
2	Dimmer (G)	3	Dimmer (G)	3	Dimmer (G)
4	Dimmer fine (G)	4	Dimmer fine (G)	4	Dimmer Fine(G)
5	Red -zone 1	5	Warm white- zone 1	5	Colour -zone 1
6	Red fine -zone 1	6	Warm white fine-zone 1	6	Colour fine-zone 1
7	Green -zone 1	7	Cool white -zone 1	7	Dimmer -zone 1
8	Green fine -zone 1	8	Cool white fine-zone 1	8	Dimmer fine-zone 1
9	Blue -zone 1	9	Dimmer -zone 1	9	Colour -zone 2
10	Blue Fine -zone 1	10	Dimmer Fine-zone 1	10	Colour fine-zone 2
11	White -zone 1	11	Colour macro -zone 1	11	Dimmer -zone 2
12	White 1 Fine	12	Warm white-zone 2	12	Dimmer fine-zone 2
13	Dimmer 1	13	Warm white fine-zone 2	:	:
14	Dimmer Fine-zone 1	14	Cool white-zone 2	33	Colour -zone 8
15	Colour macro -zone 1	15	Cool white fine-zone 2	34	Colour fine-zone 8
16	Red -zone 2	16	Dimmer -zone 2	35	Dimmer -zone 8
17	Red fine-zone 2	17	Dimmer fine-zone 2	36	Dimmer fine-zone 8
18	Green -zone 2	18	Colour macro -zone 2		
19	Green fine-zone 2	:	:		
20	Blue -zone 2	54	Warm white-zone 8		

21	Blue Fine-zone 2	55	Warm white fine-zone 82
22	White -zone 2	56	Cool white-zone 8
23	White Fine -zone 2	57	Cool white fine-zone 8
24	Dimmer -zone 2	58	Dimmer -zone 8
25	Dimmer Fine-zone 2	59	Dimmer fine-zone 8
26	Colour macro -zone 2	60	Colour macro -zone 8
:	:		
90	Dimmer 8		
91	Dimmer Fine-zone 8		
92	Colour macro -zone 8		

*no function

(G) - Global effect for all zones

Example 2.

Order of DMX channels for 8 LED output zones for different LED modules (one LED module on each LED zone). All LED zones are controlled together.

Correct type of LED modules is assigned to the corresponding fixture type via menu item "System Config" (menu CONFIG). If this assigning is not realized, SW modules and single colour modules will use 8 local channels for control (as RGBW modules).

DMX address=1, DMX mode 1 (fixed)

DMX Channel	RGBW modules Effect	SW modules Effect	Single colour modules Effect
1	Colour macro (G)	Colour macro (G)	Colour macro* (G)
2	Strobe (G)	Strobe (G)	Strobe (G)
3	Dimmer (G)	Dimmer (G)	Dimmer (G)
4	Dimmer fine (G)	Dimmer fine (G)	Dimmer Fine(G)
5	Red (zone 1,2..8)	Warm white (zone 1,2..8)	Colour (zone 1,2..8)
6	Red fine (zone 1,2..8)	Warm white fine (zone 1,2..8)	Colour fine (zone 1,2..8)
7	Green (zone 1,2..8)	Cool white (zone 1,2..8)	
8	Green Fine (zone 1,2..8)	Cool white fine (zone 1,2..8)	
9	Blue Fine (zone 1,2..8)		
10	Blue Fine (zone 1,2..8)		
11	White (zone 1,2..8)		
12	White Fine (zone 1,2..8)		

*no function

(G)=Global effect for all zones

Example 3

Order of DMX channels for 8 LED output zones for different LED modules (one LED module on each LED zone). Each LED zone is controlled separately.

DMX address=1, DMX mode 5 (8-bit without Global effects)

DMX Channel	RGBW modules Effect	DMX Channel	SW modules Effect	DMX Channel	Single colour modules Effect
1	Red -zone 1	1	Warm white- zone 1	1	Colour -zone 1
2	Green -zone 1	2	Cool white -zone 1	2	Colour -zone 2
3	Blue -zone 1	3	Warm white -zone 2	:	:
4	White -zone 1	4	Cool white -zone 2	8	Colour - zone 8
5	Red -zone 2	:	:		
6	Green - zone 2	15	Cool white-zone 8		
7	Blue - zone 2	16	Warm white-zone 8		
8	White - zone 2				
:	:				
29	Red -zone 8				
30	Green -zone 8				
31	Blue -zone 8				
32	White -zone 8				

7. Fixture menu





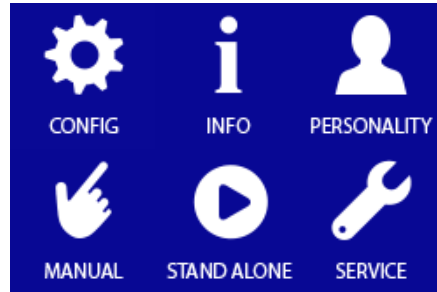

The ArcPower Unit menu allows to set the fixture according to your needs, obtain information on its operation and program it, if it has to be used in a stand-alone mode.

The fixture's menu can be controlled directly by touching desired icon.

After switching the fixture on, the display shows the initial screen for a few seconds and after that the main menu screen will appear.



Icons used in the touch screen menu.

-  - [back arrow] used to move to the previous screen
-  - [forward arrow] used to move to the next screen.
-  - [up arrow] used to scroll menu up.
-  - [down arrow] used to scroll menu up.
-  - [confirm] used to save adjusted values, to leave menu or to perform desired action.
-  - [cancel] used to leave menu item without saving changes.
-  - [back arrow] used to move to the main screen

7.1 Configuration



DMX Address ---Use the menu item to set DMX address of the ArcPower Unit, which is defined as the first channel from which the ArcPower Unit will respond to the DMX controller.

Selected DMX address has to allow inserting all channels (in set DMX mode) to one DMX universe.

DMX mode --- The menu item allows to select desired DMX mode (Mode 1-fixed, Mode 2-8 bit, Mode 3 -full 16 bit, Mode 4-fixed order, Mode 5- 8-bit without global effects, Mode 6- 16-bit without global effects).

DMX In --- The menu item allows to choose type of fixture control:

Wired - DMX signal is received by means of the standard DMX cable.

Ethernet- The signal is received by means of the Ethernet cable, supported protocols are ArtNet, MANet, MANet2, sACN.

Ethernet --- The menu allows needed settings for Ethernet operation

- Ethernet mode** - The option allows you to select desired protocol: ArtNet, gMA1, gMA2, sACN.
- Default IP Address** - Preset IP address, you can change only first byte of IP address (2 or 10) e.g. **002**.XXX.XXX.XXX or **010**.XXX.XXX.XXX.
- Custom IP Address** - The option enables to set up all bytes of IP address.
- Net Mask** - The option enables to set up all bytes of Net Mask.
- ArtNet Universe** - Use this item to set a Universe (0-255). The Universe is a single DMX 512 frame of 512 channels. The ArcPower Unit can use diagnostics packets to send diagnostic information over the network.
- MANet I/2 Universe** - Use this item to set a Universe (1-256).
- MaNet session ID** - Use this item to set a MANet session ID (1-32).
- sACN Universe** - Use this item to set a Universe (1-32000). The ArcPower Unit can receive up to 8 sACN Universes and allows to ArcPower Unit could be controlled by more controllers.

System config --- The menu allows to change setting of desired zone. Use + and - icons to select zone. After that you can change setting for the following items (number of displayed items depends on selected DMX mode and type of zone). You can change:

- Type of connected LED module
- Current (if the option Custom is selected, you can set a current for all channels together or for each channel separately)
- DMX offset for LED zone (only for DMX modes which allow this function, the red background of offset cautions that the number is wrong)
- Power limiting
- Channels (if a custom LED module is selected).

Note: we recommend to use this menu for changing setting of some zone (if it is needed) instead of using menu "Setup Assistant" because in the "Setup Assistant" you have to browse all zones in order to save changes made in one zone and as the Setup Assistant always re-counts DMX channel offsets, some changes in DMX channel offsets have to be set again.

Setup Assistant --- The menu serves as a guide of full configuration of the ArcPower Unit.

Note. Displayed options depends on selected DMX mode. If Mode 1 (fixed) is selected, the Setup Assistant is unavailable.

Procedure.

1. Select type of LED module connected to the zone 1 and touch .

- RGBW** - red/green/ blue/white LED module
- RGB** - red/green/blue LED module
- SW** - smart white LED module (with warm white and cool white LEDs).
- Single C.** - single colour LED module
- White** - white LED module
- Custom** - custom LED module (the item requires to set number of channels)

Note. We recommend to select option RGBW or Custom (4 channels) for LED modules which are not produced by Robe. Do not use RGB or SW/Single C./White options in this case.

2. Check offered channel offset for each effect on the zone 1 and touch desired channel if you need to change its offset. If DMX mode with "fine" channels is selected (Mode 3 -16-bit), the fine channels are not shown on the screen, but each fine channel is automatically assigned to the following channel after its coarse channel (e.g. if Red= DMX channel 6, Red Fine= DMX channel 7; if Blue=DMX channel 10, Blue Fine= DMX channel 11). If you are changing offered channel offset, the adjusted channel is displayed at the bottom left corner of the screen and has to be on a white background. The red background cautions that the number of the channel offset is wrong (channel is reserved for global effects) or the number is too high.

Touch  to go on the next screen.

Note: If you change DMX channel offset, the channel offset on the following zone will be re-counted in relation to this changed offset.

Range of used DMX channels you can find out by means of the item "DMX Address Range" in the menu Info.

3. Choose desired current (350mA, 700mA, Custom) for zone 1 and touch . The item Custom allows you to set LED current from 100mA to 1000mA (by 4 mA steps) by means of a slider on the screen. For SW LED modules is current range 100mA-900mA.

The current can be set for all channels together (option All ch.) or for each channel separately (option Individual ch.)

Note: Always check the max. allowed current for LED modules connected to the LED zone output of the ArcPower Unit because current overloading of the LED modules can destroy them.

4. If you wish to copy the setting of the zone 1 to the zone 2 choose option " Copy setting from Zone 01" (this option is not offered at last zone) .

If you need to set the zone 2 differently from the zone 1, select option " No, go to next step" and configure the zone 2. In this way set the rest of zones (2-8).

If you change DMX address of the LED Zone (menu "DMX Address") e.g. from 001 to 050, all channel offsets will be automatically re-counted to the new DMX address.

Power limiting --- The menu item allows to reduce LED current on desired zone. If this function is On (red icon), the sum of currents of all channels is limited to 1200mA.

Examples for current setting 350mA:

- Channel 1: 300mA
- Channel 2: 300mA
- Channel 3: 300mA
- Channel 4: 300mA
- or
- Channel 1: 150mA
- Channel 2: 350mA
- Channel 3: 350mA
- Channel 4: 350mA
- etc

Linear/Exponential --- This menu item allows you to choose desired dimmer running. Selected dimmer curve can influence local and global dimmer (option Dimmer) or colours (option Channels).

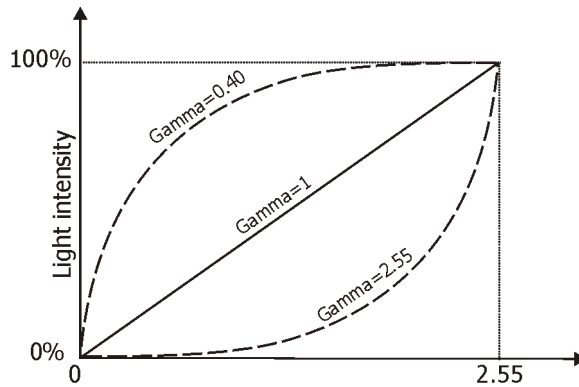

Fade Time --- The menu item allows to set fade time from 0 sec. to 25.5 sec. This time influences response on coming DMX value (e.g. dimmer is set at 20 DMX, coming DMX value is 255 and the Fade Time=10 sec. The light intensity will go from 20 DMX to 255 DMX during 10 seconds continuously without a jump).

ArcZone Pixel --- This menu serves for pixel zones only.

0-10V Zone Setting --- Use the menu item to assign the 0-10V Zone channels to the LED Zones channels. Note: If the 0-10V Zone is not installed, the message" no 0-10V zone to control" will appear.

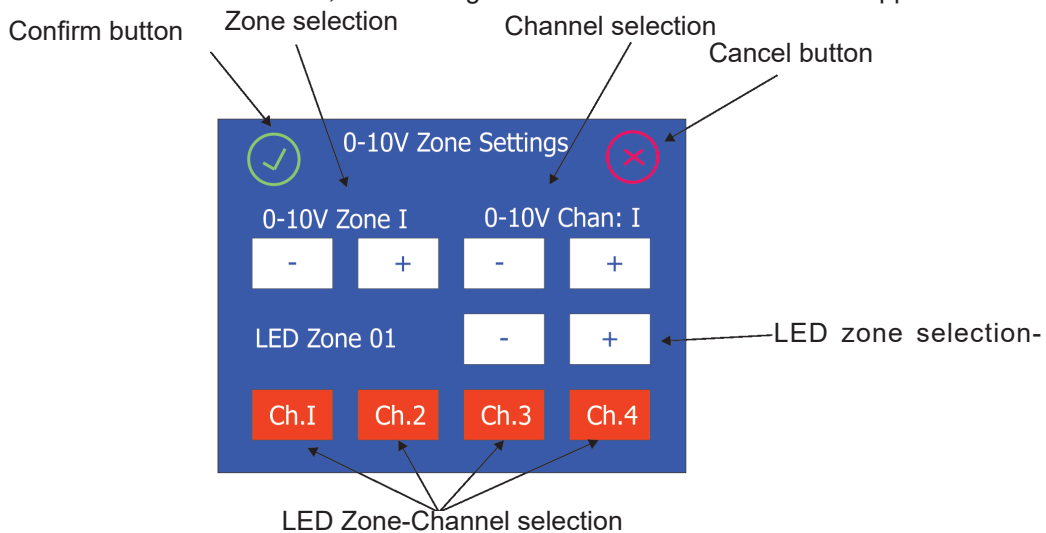

Examples:

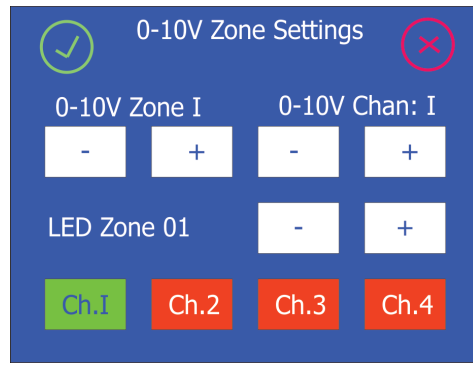

The channel 1 from LED Zone 1 is assigned to the channel 1 of the 0-10V Zone 1. When the voltage on the channel 1 is changed in range 0-10V, the channel 1 of the LED Zone 1 is controlled from min. to max. saturation (e.g. red) .

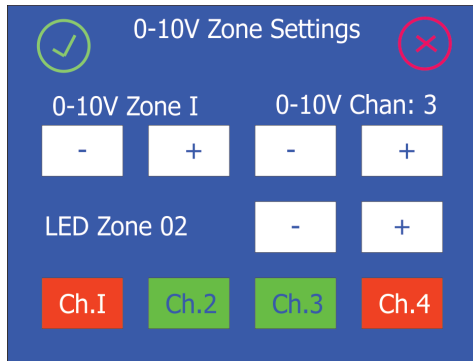

The channels 2 and 3 from LED Zone 2 are assigned to the channel 3 of the 0-10V Zone 1. When the voltage on the channel 3 is changed in range 0-10V, the channels 2 and 3 of the LED Zone 2 are controlled from 0 to full saturation min. to max. saturation (e.g. green + blue together).

Fan Zone Setting --- Use the menu item to set the Fan Zone (if the Fan Zone is installed).

Type of Sensor 1 - allows you to select desired type of a temperature sensor (PT500/PT1000/NTC) for temp. sensor input 1.

Type of Sensor 2 - allows you to select desired type of a temperature sensor (PT500/PT1000/NTC) for temp. sensor input 2.

Note: as NTC sensor use the NTC thermistor NTC10K-AWG26, 500mm (P/N 13052203)

Fan 1 Voltage - allows you to set desired voltage (12V/24V/48V for ArcPower Unit / ArcPower Unit US, 12V/24V for ArcPower Unit US LV) for supply of a fan connected to the fan output 1.

Fan 2 Voltage - allows you to set desired voltage (12V/24V/48V for ArcPower Unit / ArcPower Unit US, 12V/24V for ArcPower Unit US LV) for supply of a fan connected to the fan output 2.

Note: max. current consumption of 1 A for fan must not be exceeded.

Fan 1 Config - allows you to select a way of control of the fan 1:

Min. Pwr - the fan 1 runs at 50% of its set voltage (item "Fan 1 Voltage"). E.g. if the item Fan 1 Voltage is set at 24V, the fan 1 will run at 12V.

Max. Pwr - the fan 1 runs at 100% of its set voltage (item "Fan 1 Voltage"). E.g. if the item Fan 1 Voltage is set at 24V, the fan 1 will run at 24V.

By Sens 1 - the fan 1 runs according to the value set in the menu "Fan 1 Threshold"

By Sens 2 - the fan 1 runs according to the value set in the menu "Fan 2 Threshold".

Fan 2 Config - allows you to select a way of control of the fan 2:

Min. Pwr - the fan 2 runs at 50% of its set voltage (item "Fan 2 Voltage"). E.g. if the item Fan 2 Voltage is set at 24V, the fan 2 will run at 12V.

Max. Pwr - the fan 2 runs at 100% of its set voltage (item "Fan 2 Voltage"). E.g. if the item Fan 2 Voltage is set at 12V, the fan 2 will run at 12V.

By Sens 1 - the fan 2 runs according to the value set in the menu "Fan 1 Threshold"

By Sens 2 - the fan 2 runs according to the value set in the menu "Fan 2 Threshold".

Note: Both fans can be controlled by one temperature sensor.

Fan 1 Threshold - allows you to set a temperature (10°-60°) which will be used for a control of the fan 1 speed.

Fan 2 Threshold - allows you to set a temperature (10°-60°) which will be used for a control of the fan 2 speed.

Relationship between a temperature set in the Fan 1 Threshold (Fan 2 Threshold) menu

describes the graph below.

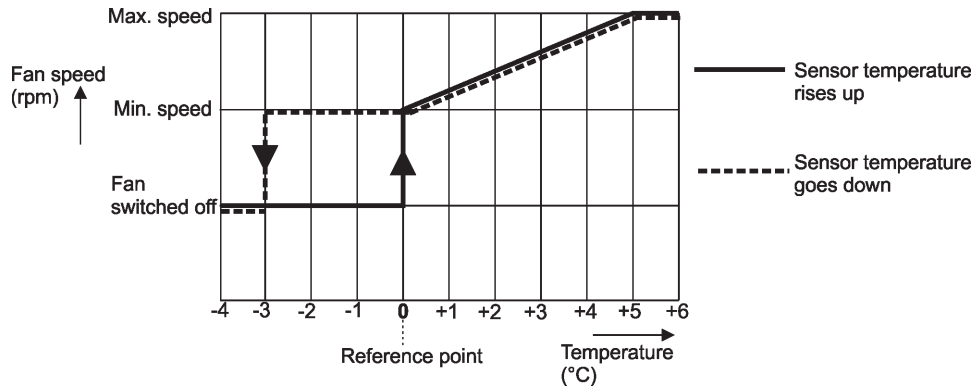

E.g. If a temperature in the Fan1 Threshold menu is set at 40°C, the controlled fan will behave as follows:

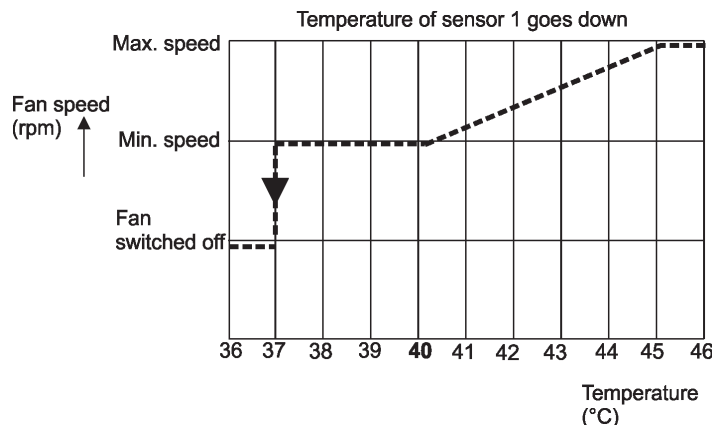
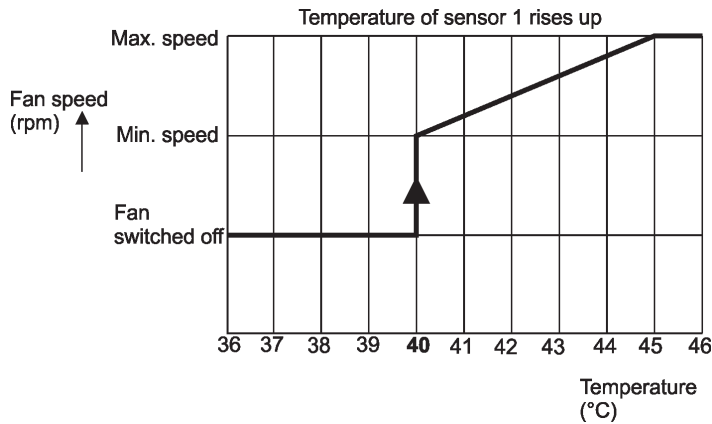

- Fan 1 RPM Sens.** - allows you to activate measuring of fan 1 revolutions if the fan is equipped with three lead wires (+,-, output signal).
 - Not Available** - select this option if the fan 1 is not equipped with 3rd wire for measuring of rpm.
 - Available** - select this option if the fan 1 is equipped with 3rd wire for measuring of rpm.
- Fan 2 RPM Sens.** - allows you to activate measuring of fan 2 revolutions if the fan is equipped with three lead wires (+,-, output signal).
 - Not Available** - select this option if the fan 2 is not equipped with 3rd wire for measuring of rpm.
 - Available** - select this option if the fan 2 is equipped with 3rd wire for measuring of rpm.

Main Power Fan --- Use the menu item to set a way of control of fan(s) in the ArcPower Unit.
Auto - revolutions of fans depend on a current load. If the current load of the ArcPower Unit falls below 20 W, the fans will stop operation.

If the current load of the ArcPower Unit exceeds 30 W, the fans will start operation at min. revolutions (=35% of max. revolutions). Fans speed will increase depending on increasing load.

Max - fans operate on max. revolutions.

Quiet- fans revolutions (noise) can be set by means of the slider in the range of 1-100 (100=max. rpm).

OFF=fans off. Set value is a max. speed limit for fans (revolutions will move in range of min. revs to set max. revs , depend on current load). Set max. revolutions of fans influence power to LEDs.

Relationship between fans revolutions and power to LEDs:

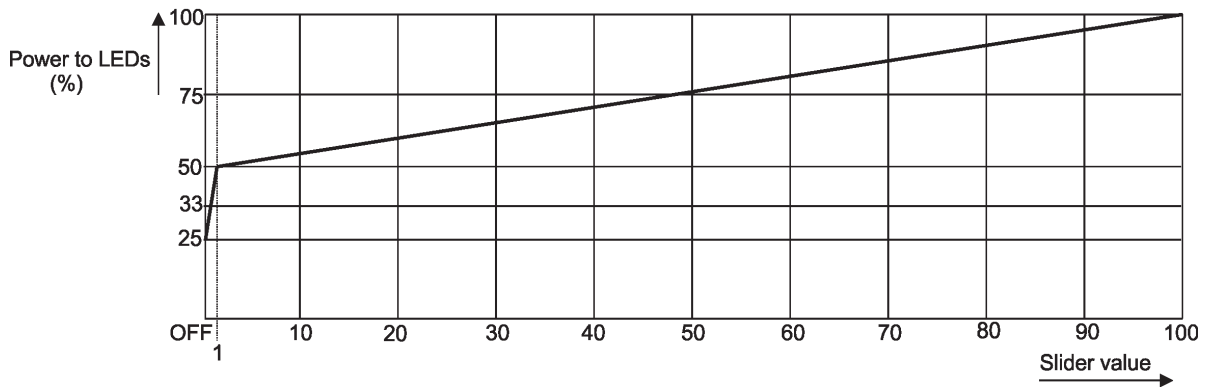
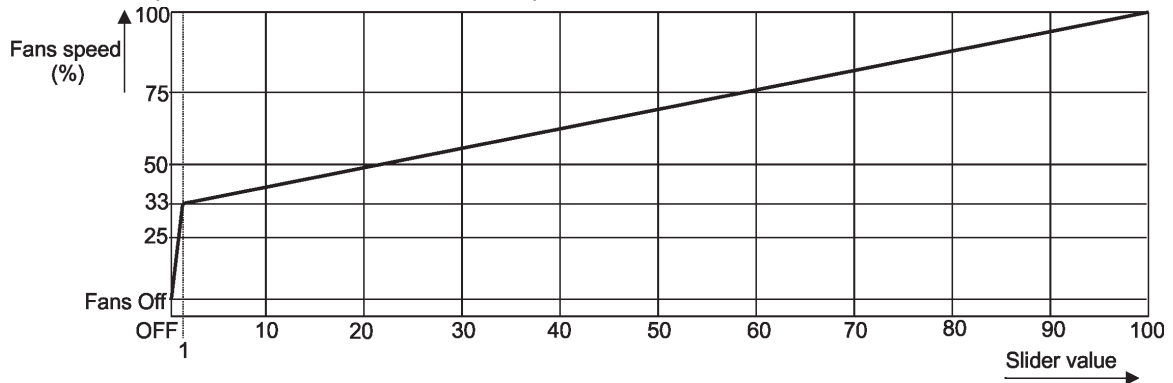

E.g. If the slider is set at 60, fans will operate in the range min. revs - 75% max. revs depend on current load.

Note: fans operate on max. speed for a short time when you switch on the ArcPower Unit or adjust fans speed from off to the desired level via the slider.

Power Supply --- the menu item serves for DRS only.

7.2 Information



Rack Unit overview --- Use the menu item to read:

DMX address

Connected zones

Installed load

Selected input (red letters=no signal is receiving, green letters=signal is receiving)

Power On Time (total number of operation years/days/hours since the ArcPower Rack Unit has been fabricated).

Version --- Use the menu item to read the software version of the control display unit and the hardware version of the control display unit. The versions are separated by a slash.

On the other lines are software and hardware versions (separated by a slash) of LEDS zones.

DMX address range --- Use this menu item to read the range of used DMX addresses for LED zones.

Zone Info --- Use this menu to read detail information of each zone setting:

Type of zone

Fixture type

Channels used

Power limiting

Current (displayed for each channel in the order: channel 1, channel 2, channel 3, channel 4)

By means of the + and - icons select desired zone.

Example:

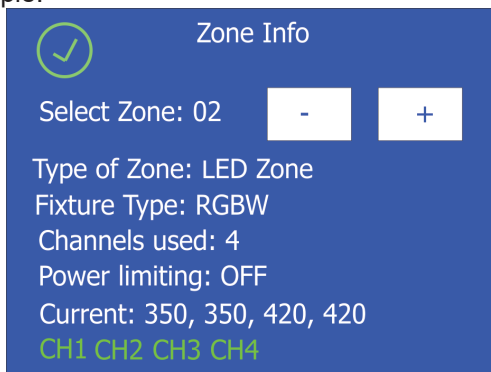

The green channels mean that connected LED module to the zone 2 has four channels (physically).

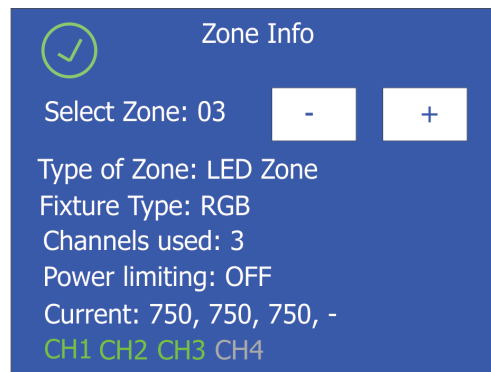

The green channels mean that connected LED module to the zone 3 has three channels (physically).

Note: zone 0-10V shows input value(0-255) on each channel (0=0V, 128= 5V, 255=10V).

By means of the + and - icons select desired zone.

Real Time Zone (ArcZone DRS RTC) shows a set time on line below the zone.

Temperatures --- Use this menu to read temperature of each zone and temperature of connected LED module (in case that LED module has a temperature sensor). Temperatures can be displayed in °C or °F.

By means of the + and - icons select desired zone.

Board actual / max. - a current temperature of the zone inside / max. temperature of the zone inside since the unit has been fabricated.

Board max R. - a max temperature of the zone inside since the counter was last reset. To reset this counter, touch the button shows this temperature.

LED actual / max. - a current temperature of the connected LED module / max. temperature of the connected LED module since the LED module has been fabricated.

LED max R. - a max temperature of the LED module since the counter was last reset. To reset this counter, touch the button shows this temperature.

RDM info --- Use this menu item to read the RDM number and Device label.

DMX Channels overview --- Use this menu to display channels with associated effects, DMX addresses and

DMX values for each effect. zone.

By means of the + and - icons select desired zone (or first or second part of desired zone).

Log View --- Use this menu to read important messages which have been recorded during fixture operation.

By means of the + and - icons browse through recorded logs.

Log nr. - number of the log

On date - date of recording of the log

On POT - power on time at recording the log.

Recorded events are colour differentiated:

Notice in red - error

Notice in yellow - warning

Notice in green - change of the ArcPower Unit setting.

7.3 Personality



Display Intensity - Use the menu to adjust the display intensity (1-min., 10- max).

Default Settings --- The menu item sets fixture parameters to the default (factory) values.

Note: All user settings will be lost except changes in the menu "Save Init Position" (menu Personality) and changes in the menu "Edit Program" (menu Stand alone).

Screen saver --- Use this menu item to switch OFF/ON the screen saver and to set time period (30 sec.-600 sec.) after that the display will be turned off. If the option Off is selected, the screen will permanetly light.

Lock screen --- Use the menu item to lock the screen.

Set Unlock code --- The menu item allows to enter password in order to prevent unauthorized person from changing setting of the fixture. This code is required after switching the fixture on and after waking from screen saver.

Disable Unlock code --- The menu item disables "Unlock code" function.

Emergency Trig --- The menu item allows to set an action, which will be performed after pressing the emergency button (the button connected to the trigger input).

OFF - state of LED modules is without change.

ON - all fixtures full - the function is on, all LEDs in LED modules will light.

ON - all fixtures off - the function is on, all LEDs in LED modules will be turned off.

Date/Time --- The menu item allows you to set a current date and time. The date and time is saved in the ArcPower Unit by one of the following ways:

1. Into the control display of the ArcPower Unit if the Real Time Zone (RTC) is not installed.

In case that the ArcPower Unit has been disconnected from mains and after a lapse of time is connected to mains, both date and time run from values before disconnecting mains. You have to set the date and time again to keep them current.

2. Into the Real Time Zone (RTC) if the zone is installed.

In case that the ArcPower Unit has been disconnected from mains and after a lapse of time is connected to mains, both date and time run without interruption and still keep current values due to a battery of the Real Time Zone. A presence of the Real Time Zone in the ArcPower Unit is indicated by the Battery line on the screen.

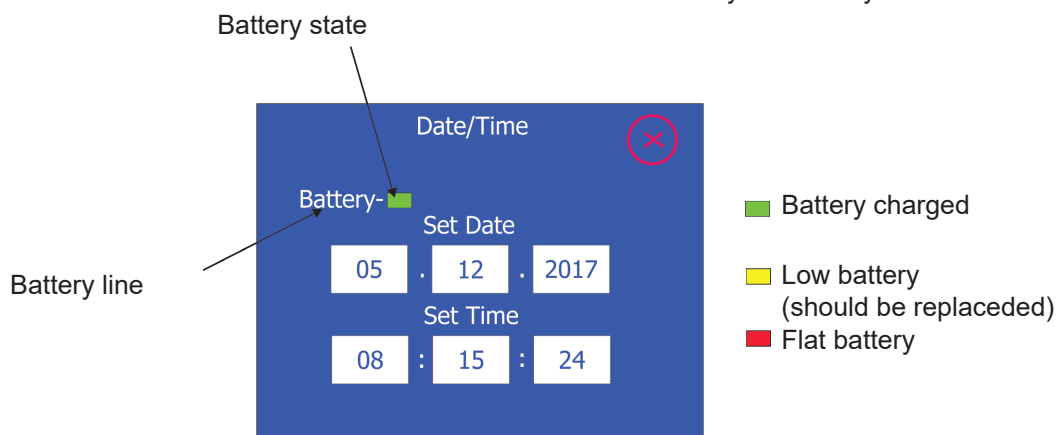

Real Time Zone information.

Accuracy of the Real Time Zone is typically +/-5 seconds per year. The battery should be replaced when a yellow field is displayed on the battery line. Disconnect the ArcPower Unit from mains before changing the battery.

After connecting ArcPower Unit to mains, a self-test of battery is performed and than every 24 hours. After changing the battery, set the date and time again.

In case of low or flat battery, error messages will appear on the main screen - see the item Diagnostic (in the menu Special Functions).

Init Position --- This menu allows to set behaviour of ArcPower Unit after switching it on if no DMX (or ArtNet or other Ethernet based protocol) signal is present.

Table - LED modules will light according the values saved in the item "Save As Init Position" in the menu Manual.

Prog.1 - ArcPower Unit will run the program 1 - see menu Stand alone.

Prog.2 - ArcPower Unit will run the program 2 - see menu Stand alone.

Prog.3 - ArcPower Unit will run the program 3 - see menu Stand alone.

all OFF - All LED modules will be off (default setting)

all ON - All LED modules will light at max. light output.

7.4 Manual mode



This menu serves for LED Zones only.

After entering this menu, both DMX and Ethernet inputs are blocked for LED Zones.

Channels For All --- Use the menu to set DMX values for local effects on all zones at the same time.

Channels By Zone --- Use the menu to set DMX values for local effects for each zone individually. By means of touching icons - and + you can browse zones.

Other By Zone --- Use this menu to set DMX values for dimmer, dimmer fine and colour macro for each zone.

Manual global --- Use this menu to set DMX values for global effects (go for all zones): dimmer, dimmer fine, colour macro, strobe.

Save Init Position --- Use this menu to set values which will be used after switching the fixture on without present of DMX or Ethernet signal. The item "Table" has to be selected in the menu item "Init Position" (menu Personality).

7.5 Stand-alone setting



After entering this menu, both DMX and Ethernet inputs are blocked for LED Zones.

Test sequence --- This menu item runs test sequence on all zones, you can set step time (1-9 sec.) and fade time (0-9sec.) for the test sequence.

Play Sequence - starts test sequence

Stop Sequence - stops test sequence

Play program --- Use this menu to run a desired program in a loop.

Edit Program --- Use this menu to create program or edit program.

The fixture offers 3 programs with up to 40 steps each.

To create a program

1. After entering the item Edit program, select desired program (Program 1 -Program 3) and enter it.

2. The first programming screen allows to edit global channels and fade/step time for prog. step. 1.

Step selection Change screen Step selection Change screen Global channels

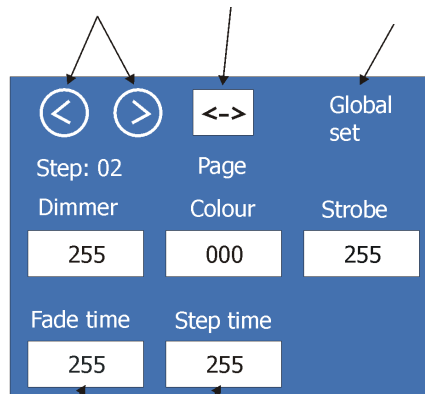
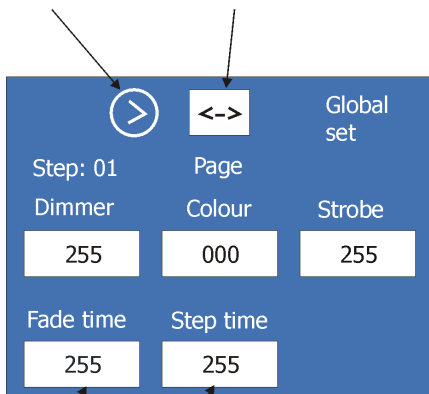

(0-25.5 sec.) (0-25.5 sec.)

(0-25.5 sec.) (0-25.5 sec.)

Note: 255=25.5sec., 100=10 sec., 10=1 sec. 1=0,1sec.

Use the buttons to change program step.

3. Touch the button to display the second screen which allows to edit local channels for actual step.

Use the buttons to display desired zone.

Step selection Change screen Step selection Change screen Zone selection

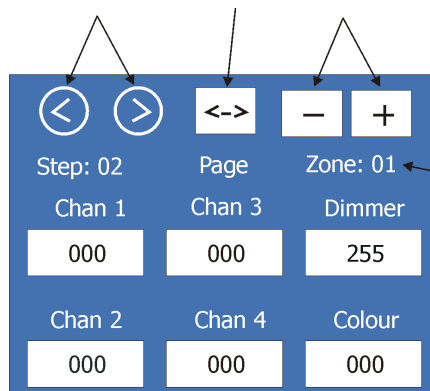

zone number

Use the buttons to change program step.

4. Touch the button  to display the third screen which allows to copy settings from actual step to the next step or to finish programming and save created prog. steps.

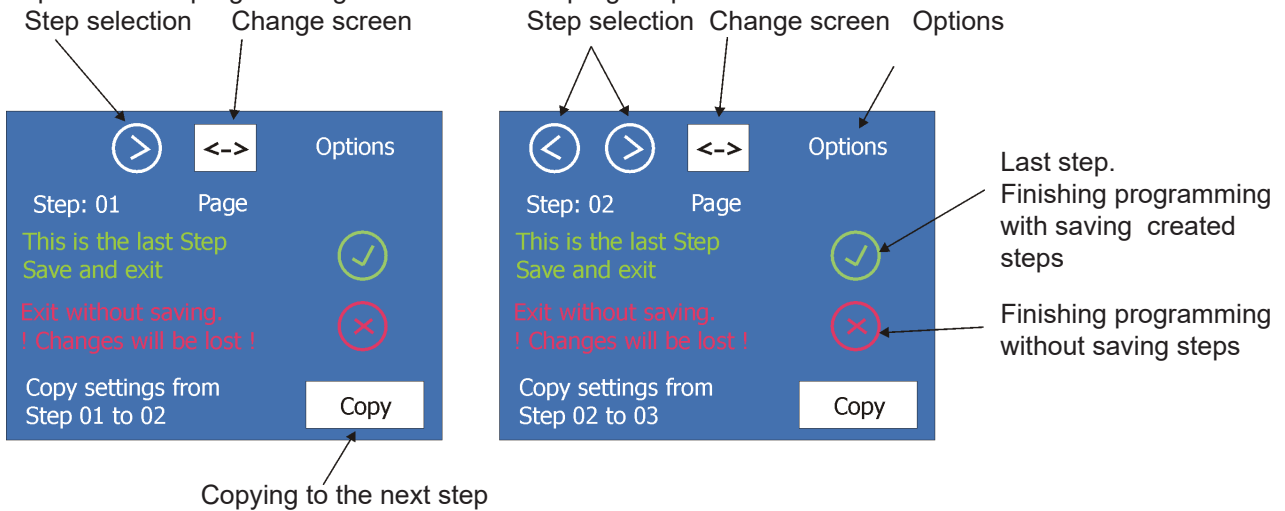

Program 1 Run Set --- Use this menu to set a mode of the run of the program 1.

Program 2 Run Set --- Use this menu to set a mode of the run of the program 2.

Program 3 Run Set --- Use this menu to set a mode of the run of the program 3.

Every menu item stated above allows to choose 2 modes of the program running.

Manual - If this option is selected, corresponding program can be run by the menu "Play Program" only.

by RTC - If this option is selected, the corresponding program will run in time period which is defined in the following screen (e.g. Program 1 Run Set):

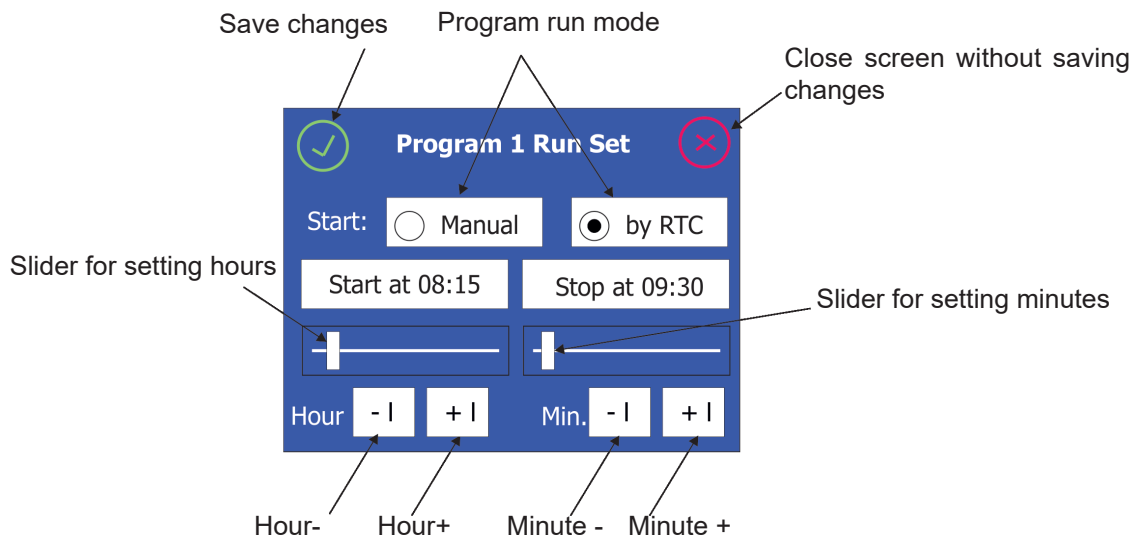

The program, which is controlled by the option "by RTC", can be also run via the menu "Play Program".

Note: The only one program can have the option "by RTC" active. If you activate the option "by RTC" at another program (e.g. Program 2 Run Set), the Program 1 Run set will be automatically set to the option manual "Manual".

All Chan. Together --- the menu item allows you to saturate all channels of connected LED modules (RGB, RGBW, single colour, smart white and pixel modules) on desired level - all LED modules will light. This function is useful for fast check of functionality of connected LED modules.

All by channels --- the menu item allows you to saturate red, green, blue and white channels on all LED zones.

7.6 Special Functions



Diagnostic --- The menu item runs diagnostic of the ArcPower Unit. There is a list of error (or warning) messages.

Note: message in red - error, message in yellow - warning

Overload - The ArcPower Unit is overloaded. Disconnect some LED modules or reduce LED current.

To many zones or not identified - probably some zone is faulty.

LED thermistors - Some LED module with a temperature sensor has been disconnected from the LED zone since last operation of ArcPower Unit.

Corresponding LED zone works, but its output power is reduced to 20% (from a safety reason).

The following error messages refer to the Fan Zone only. In all cases stated below the corresponding fan does not run.

Fan 1:1 - Fan 1 has been set to 48V (menu Fan 1 Voltage), but the 48V power supply is not available in the Arc Power Unit US LV.

Fan 2:1 - Fan 2 has been set to 48V (menu Fan 2 Voltage), but the 48V power supply is not available in the Arc Power Unit US LV.

Fan 1:2 - PCB of the fan 1 in the Fan Zone is overheated.

Fan 2:2 - PCB of the fan 2 in the Fan Zone is overheated.

Fan 1:4 - Type of a temperature sensor is not set in the menu Type of Sensor 1.

Fan 2:4 - Type of a temperature sensor is not set in the menu Type of Sensor 2.

Fan 1:8 - Short circuit on output terminals for fan 1.

Fan 2:8 - Short circuit on output terminals for fan 2.

Fan 1:16 - Max. output current (1A) for fan 1 was exceeded.

Fan 2:16 - Max. output current (1A) for fan 2 was exceeded.

Fan 1:32 - Too low revolutions (<400 rpm) of the fan 1 (if measuring of fan rpm was enabled).

Fan 2:32 - Too low revolutions (<400 rpm) of the fan 2 (if measuring of fan rpm was enabled).

The following error messages refer to the Real Time Zone only.

Battery is not in ideal condition - the battery of the Real Time Zone has low voltage and should be replaced.

Replace battery - the battery of the Real Time Zone is flat and has to be replaced.

The item "Servis" at the right bottom corner of the screen Diagnostic serves for service purposes only.

SW update/Reset --- the menu allows you to update software in the ArcPower Unit or reset the ArcPower Unit.

FirmWare Update - the menu item serves for updating software in the ArcPower Unit and all LED zones

The following items are required in order to update software:

- PC running Windows or Linux or macOS
- DSU file
- Flash cable RS232/DMX P/N13050624 (if you want to use a serial port of PC)
- Robe Universal Interface or Robe Universal interface WTX (if you want to use an USB port of PC)

To update software in the fixture:

1. DSU file is available from the Robe web site at <https://www.robe.cz/architectural/download/#software-updates>.
File with extension zip is intended for Windows (used and tested from XP to W10 on 32/64bit systems).
File with extension tbz is intended for Linux (used and tested on Debian and Ubuntu 32/64bit).
File with extension dmg is intended for macOS (used and tested on OSX up to Sierra) XQuartz required, install it from <https://www.xquartz.org/>
Save the download file to a folder on your computer.
In case that you use windows, extract files in the zip file (e.g. DSU_ArcPowerUnit_18020957.zip)
2. Disconnect the fixture from DMX controller.
3. If you use the flash cable RS232/DMX, connect a serial port of your computer with DMX input of the fixture by means of the cable.
If you use the Robe Universal Interface, connect a USB port of your computer with the Robe Universal Interface

by means of the USB cable and DMX input of the fixture with the DMX output of the Robe Universal Interface via a DMX cable.

Example for connection via the Robe Universal Interface:

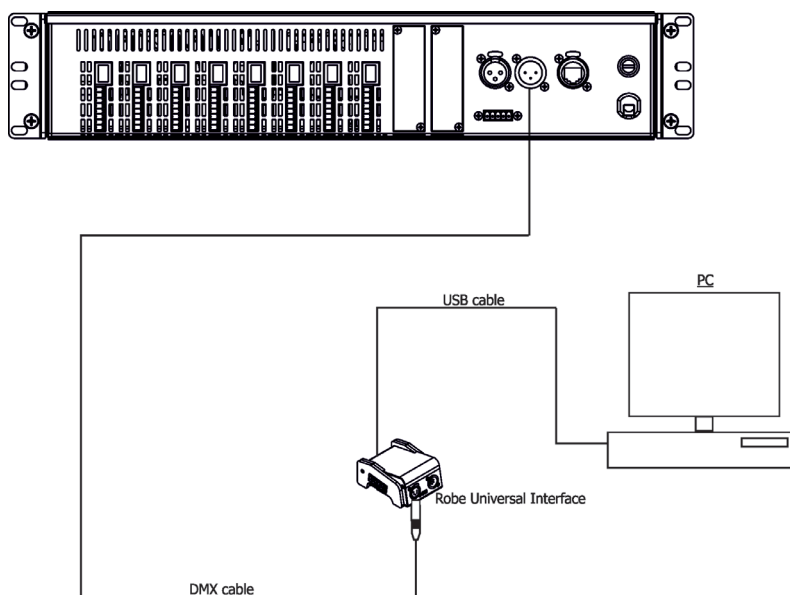

4. Switch the fixture to the update mode (Service --> SW update/Reset --> FirmWare Update).
Note: If you do not want to continue in the software update, you have to switch off and on the fixture to escape from the updating mode.
We recommend to cancel all running programs on your computer before starting the software update.
5. Double-click the software uploader file (e.g. DSU_ArcPowerUnit_18020957.exe) in the extracted files. The Software Uploader program will start running.

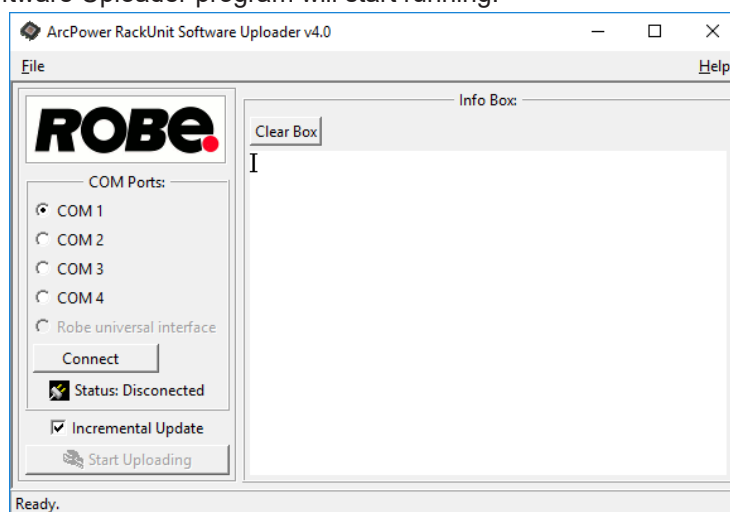

6. Select correct "COM " number if you use a Flash cable RS232/DMX or select "Robe Universal Interface " if you use the Robe Universal Interface/Robe Universal Interface WTX and then click on the "Connect" button.
7. If the connection is OK, click the "Start Uploading" button to start software uploading. It will take several minutes to perform software update.
If the option "Incremental Update" is not checked, all processors will be updated (including processors with the same software version).
If you wish to update only processors with not topical versions of software, check the "Incremental Update box".
Avoid interrupting the process. Update status is being displayed in the "Info Box" window.
When the update is finished, the line with the text "Fixture is successfully updated" will appear in this window.

In case upload process is interrupted (e.g. power loss), the fixture stays in "Updating mode" and you will have to repeat the software update again.

Another way, how to update software in the fixtures (especially large installation of fixtures) is to use the ROBE Uploader. It is a software for automatized software update of Robe fixtures. It can take advantage of Ethernet ports and RDM support if present in the units.

For more information please see <https://www.robe.cz/robe-uploader/>.

Example for Ethernet connection:

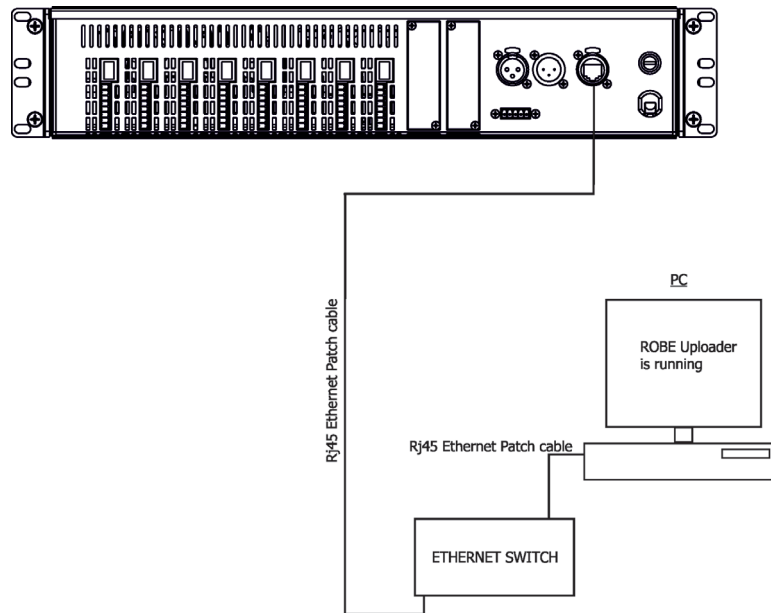

Reset device - use the menu item to reset the ArcPower Unit.

Pixel flash - the menu serves for pixel modules only.

Load test --- Use this menu item to run test whether the ArcPower Unit is able to supply all connected LED modules.

TTouch Calibration --- Use this menu item to run a calibration of the touch screen. The following message will appear on the screen:

Do you want to calibrate touch screen?

Tap on the screen..

Touch the screen and follow instructions on the screen. The calibration of the touch screen can be also initialized by touching and holding the touch screen for 5 seconds. The main menu screen has to be displayed.



8. Diagnostic query

The ArcPower Unit can reply to a diagnostic query (ArtDiag/ArtPoll). The reply depends on the priority of query and is the following:

1. Priority $\leq 0x10$ - the ArcPower Unit DRS sends real-time total dimmer (32 bit = 8bit for CH1, 8bit for CH2, 8bit for CH3 and 8bit for CH4, calculated from both global dimmer and local dimmer), size of the packet depends on number of connected zones.

2. Priority $\leq 0x40$ - DRS sends real-time power (8 bit, positions B0..B31, used positions according to the number of zones, a figure gives power in watts) + flags of individual zones (8 bit, positions B32..B63, used positions according to the number of zones, meaning of the flags - see the table below) + rest of the total packet 511B is filled with "0".

Flag	Meaning
b0	Channel 1 (Red): 1=disconnected, 0=connected
b1	Channel 2 (Green): 1=disconnected, 0=connected
b2	Channel 3 (Blue): 1=disconnected, 0=connected
b3	Channel 4 (White): 1=disconnected, 0=connected
b4	1= short circuit
b5	Reserved
b6	Trigger button 1= ON, 0= OFF
b7	Temperature sensor: 1=disconnected, 0=connected

9. Technical Specifications

Power supply

Input voltage:

ArcPower Unit Rack Mount/ ArcPower Unit Wall Mount: 100-240V AC, 50-60 Hz
ArcPower Unit Rack Mount US/ ArcPower Unit Wall Mount US: 100-277V AC, 50-60 Hz
ArcPower Unit Rack Mount US LV,/ArcPower Unit Wall Mount US LV: 100-277V AC, 50-60 Hz

Max. power consumption:

ArcPower Unit Rack Mount/ ArcPower Unit Wall Mount: 1350 W
ArcPower Unit Rack Mount US/ ArcPower Unit Wall Mount US: 1350 W
ArcPower Unit Rack Mount US LV/ ArcPower Unit Wall Mount US LV: 700 W

Max. output power*:

ArcPower Unit Rack Mount/ ArcPower Unit Wall Mount 1200 W
ArcPower Unit Rack Mount US/ ArcPower Unit Wall Mount US: 1200 W
ArcPower Unit Rack Mount US LV/ ArcPower Unit Wall Mount US LV: 600 W

Main fuse: T 16A

* Max. output power is sum of power consumptions of individual LED zones (and special zones) and their loads (e.g. LED modules, fans for ArcZone DRS Fan etc.).

Control & Programming

Setting and addressing: graphic touch screen

Control options: DMX, Art-Net, MANet, MANet2, sACN

Stand alone operation

3 user programs, each up to 40 steps

Number of LED zones: 8 (6 for ArcPower Unit Rack Mount US LV/ ArcPower Unit Wall Mount US LV)

DMX data in/out: Locking 5-pin XLR

Ethernet: RJ45

Further features: output 12V DC /100mA (counterpart P/N 13052503 included)
input for trigger (5V DC max.) (counterpart P/N 13052503 included)

LED Zone

Max. output voltage:

ArcPower Unit Rack Mount/ ArcPower Unit Wall Mount: <50V DC
ArcPower Unit Rack Mount US/ ArcPower Unit Wall Mount US: <50V DC
ArcPower Unit Rack Mount US LV/ ArcPower Unit Wall Mount US LV: <30V DC

Number of channels: 4

Output current per channel: 100 mA -1A (100mA -900mA for SW LED modules)

ArcPower Unit Rack Mount/ ArcPower Unit Wall Mount and ArcPower Unit Rack Mount US/ ArcPower Unit Wall Mount US: Max. 12 multi chip LEDs or 48 single chip LEDs total

(but max. 12 single chip LEDs per channel i.e. 12+12+12+12)

ArcPower Unit Rack Mount US LV/ ArcPower Unit Wall Mount US LV: Max. 6 multi chip LEDs or 24 single chip LEDs total (but max. 6 single chip LEDs per channel i.e. 6+6+6+6).

Max. Load: 192 W (ArcPower Unit Rack Mount/ ArcPower Unit Wall Mount)

192 W (ArcPower Unit Rack Mount US/ ArcPower Unit Wall Mount US)

118 W (ArcPower Unit Rack Mount US LV/ ArcPower Unit Wall Mount US LV)

LED connection*: RJ45

pluggable terminal block (counterpart P/N 13052502 included)

* *Only one type of LED output can be used.*

Temperatures

Operating Ambient Temperature: 0°C / +50°C (+32°F / +122°F)

Operating Temperature: +75°C @ Ambient +50°C (+167°F @ Ambient +122°F)

Total heat dissipation (calculated)

ArcPower Unit Rack Mount/ ArcPower Unit Wall Mount: 4606 BTU/h

ArcPower Unit Rack Mount US/ ArcPower Unit Wall Mount US: 4606 BTU/h

ArcPower Unit Rack Mount US LV/ ArcPower Unit Wall Mount US (LV): 2388 BTU/h

Protection factor

ArcPower Unit Rack Mount/ ArcPower Unit Wall Mount: IP20

ArcPower Unit Rack Mount US/ ArcPower Unit Wall Mount US: Suitable For Dry Locations

ArcPower Unit Rack Mount US LV/ ArcPower Unit Wall Mount US (LV): Suitable For Dry Locations

Weight

6.5 kg

Dimensions

mm [inch]

ArcPower Unit Rack Mount

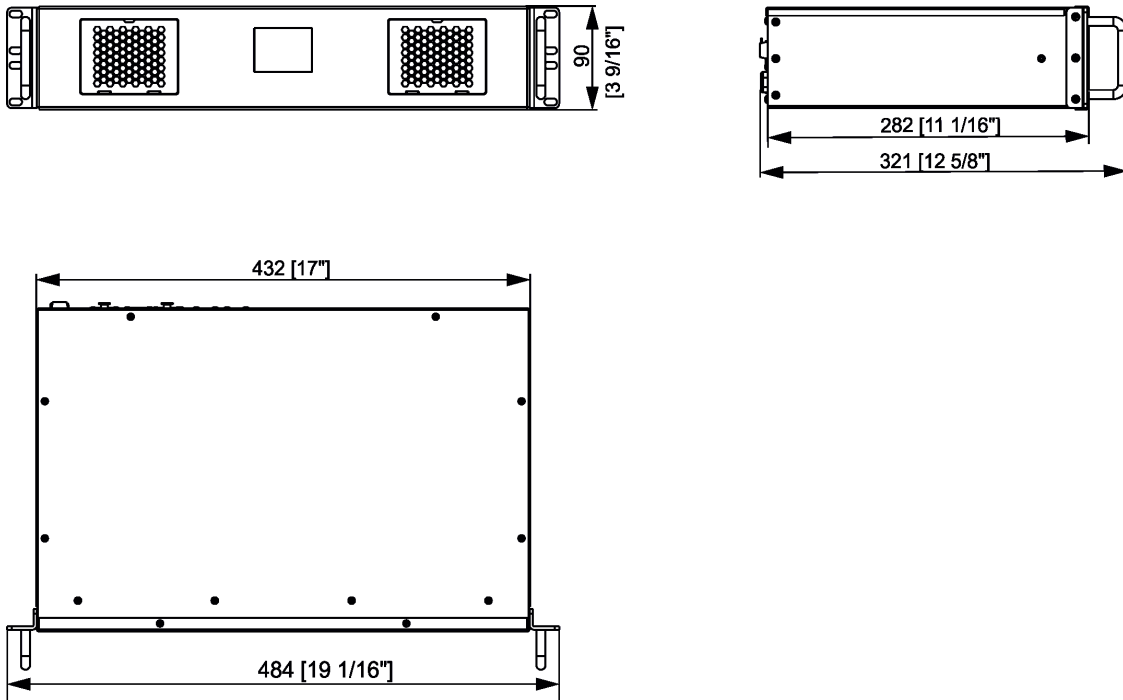

ArcPower Unit Wall mount

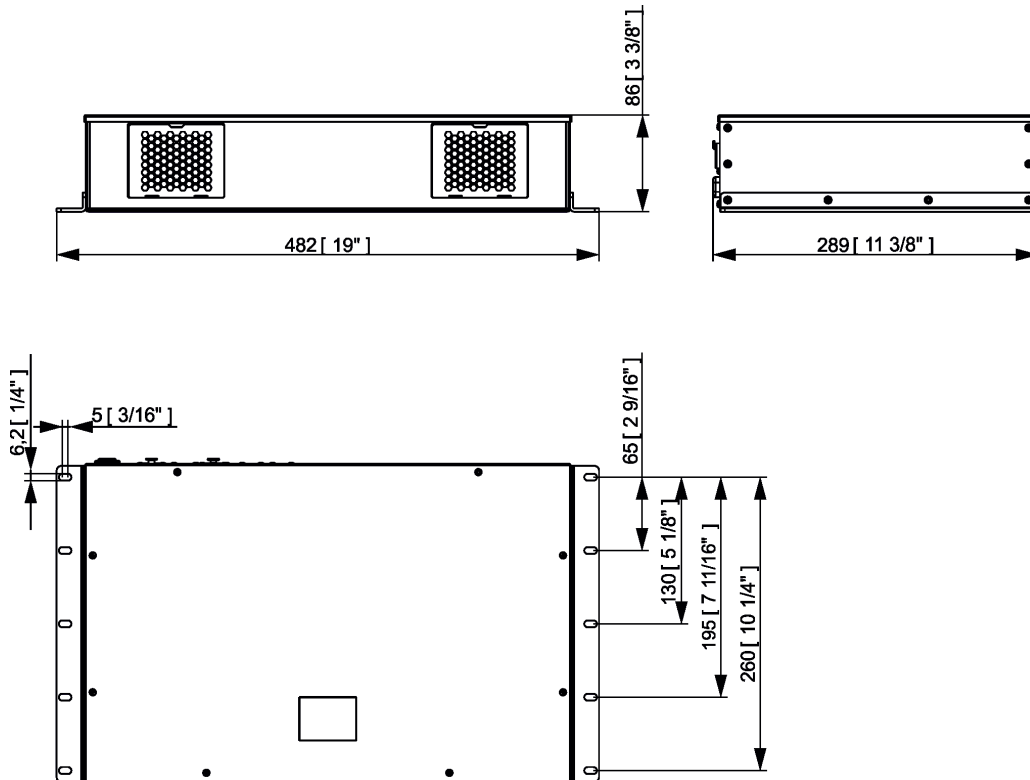

Included items

1 x ArcPower Unit
8 x Connector BCP-381-8GN (P/N 13052502) for ArcPower Unit /ArcPower Unit US
6 x Connector BCP-381-8GN (P/N 13052502) for ArcPower Unit US LV
1 x Connector BCP-381-5GN (P/N 13052503) for ArcPower Unit /ArcPower Unit US/ ArcPower Unit US LV
2 x Air filter (P/N 17031023)

Optional zones

Two free slots of the ArcPower Unit allows to install two optional zones according to customer needs.

Fan Zone

0-10V Zone

Real Time Zone

Optional zones specifications

ArcZone 0-10V

Input voltage: 28-49.5V DC

Power consumption: 1W (without LED module)

Connection:

Power input: Plug-in terminal block (5-pin)

Power output: pluggable terminal block (5-pin)

4 x input 0-10V DC: pluggable terminal block 8-pin (counterpart P/N 13052502 included)

Weight: 0.2 kg

Operating Ambient Temperature: 0°C / +50°C (+32°F / +122°F)

ArcZone RTC

Input voltage: 28-49.5V DC

Power consumption: 1W

Battery: CR2032/3V Lithium Battery or CR2032 P/H-T Lithium Battery (3V)

Connection:

Power input: Plug-in terminal block (5-pin)

Power output: pluggable terminal block (5-pin)

Operating Ambient Temperature: 0°C / +50°C (+32°F / +122°F)

Weight: 0.2 kg

ArcZone Fan

Input voltage: 28-49.5V DC

Power consumption: 1W (without fans)

Max. output power: 96W (at 2 x fan 48V/1A)

Number of fan outputs: 2

Max. fan current: 1A (per one fan output)

Fan voltage: 12V/24V/48V (12V/24V for ArcPower Unit US LV)

RPM measurement (if fan have signal wire).

Max. number of connected temperature sensors: 2

Supported temperature sensors: PT500, PT1000, NTC (only NTC thermistor NTC10K-AWG26 500mm,EPCOS, P/N 13052203)

Connection:

Power input: Plug-in terminal block (5-pin)

Power output: pluggable terminal block (5-pin)

Fans output: 2 x pluggable terminal block 3-pin (counterpart P/N 13052504 included)

Temp. sensors input: pluggable terminal block 5-pin (counterpart P/N 13052503 included)

Max. 1 ArcZone DRS Fan can be connected to the ArcPower Unit

Weight: 0.2 kg

Operating Ambient Temperature: 0°C / +50°C (+32°F / +122°F)

NTC thermistor NTC10K-AWG26, 500mm (P/N 13052203), for ArcZone Fan

Optional zones connections

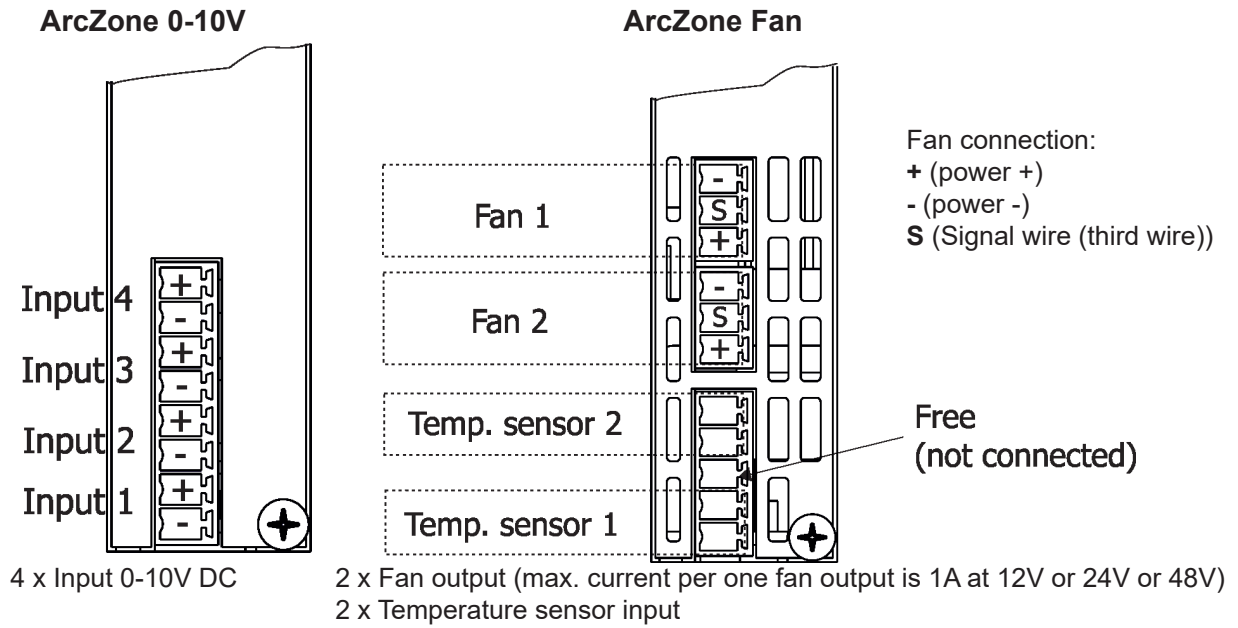

10. Maintenance

DANGER !
Disconnect from the mains before starting any maintenance work

10.1 Replacing the air filters

The ArcPower Unit is equipped with 2 air filters placed in front panel of the fixture.

To replace the air filters.

1. Disconnect the fixture from mains.
2. Open the protective grid (1).
3. Pull out the air filter (2).
4. Clean or replace the air filter (clean the air filters with a vacuum cleaner or you can wash them and put back dry).
5. Put the filter cover back to the protective grid and close the protective grid (1).
6. Repeat the same procedure for the second air filter.

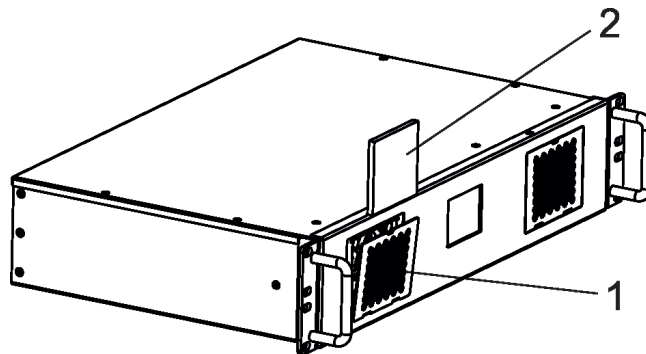

10.2 Replacing the main fuse

Only replace the fuse by the one of the same type and rating.

To replace the fuse.

1. Disconnect the fixture from mains.
2. Unscrew the fuse holder on the rear panel of the fixture with a fitting screwdriver from the housing (anticlockwise).
3. Remove the old fuse from the fuse holder.
4. Install the new fuse in the fuse holder.
5. Replace the fuse holder in the housing and screw it.

10.3 Disposing of the product

To preserve the environment please dispose or recycle this product at the end of its life according to the local regulations and codes.

11. ChangeLog

This section summarizes changes in the user manual.

Version of the manual	Date of issue	Description of changes
1.5	02/02/2018	Max. current for SW LED modules reduced to 900mA
1.6	12/02/2018	Software update description changed
1.7	08/03/2018	DMX Mode 6 added
1.8	13/08/2018	FirmWare update description changed
1.9	28/08/2018	Fixture renamed to the ArcPower Unit Rack Mount, ArcPower Unit Wall Mount
2.0	15/11/2018	Current setting for individual channels added (menu Setup assistant)
2.1	31/01/2019	Changes in menu Zone info.
2.2	30/09/2019	Added information about diagnostic query (ArtDiag/ArtPoll)
2.3	13/12/2019	Radio interference warning added
2.4	15/12/2020	12V output connector description changed
2.5	11/02/2021	Menu Touch calibration added

February 11, 2021

Copyright © 2017-2021 Robe Lighting - All rights reserved

All Specifications subject to change without notice

Made in CZECH REPUBLIC by ROBE LIGHTING s.r.o. Palackeho 416/20 CZ 75701 Valasske Mezirici