

User manual

Ambiane TD

The unit generates colored light by means of high power LEDs. The product was designed for indoor use only.

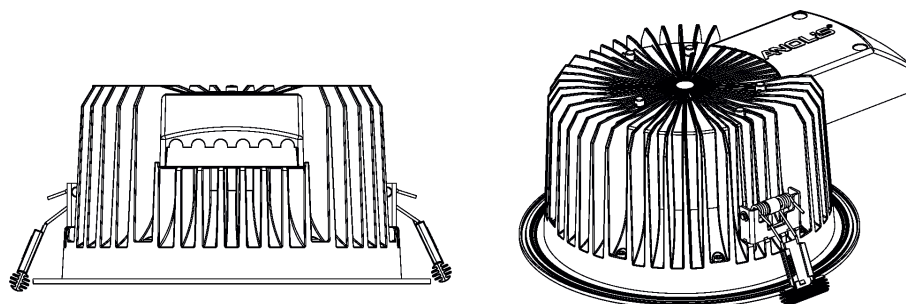

1. Attention

The unit must be installed by a qualified electrician in accordance with all national and local electrical and construction codes and regulations. The unit was designed for indoor use only.

Avoid looking directly into the LED light beam at close range!

Do not install the unit near highly inflammable liquids or materials.

Do not allow anything to rest on the unit.

Do not install the unit near an open flame.

Do not install the unit in dirty, dusty or badly ventilated location.

Sufficient air accessing to the housing of the unit has to be ensured, there must not be any heat or anti-noise insulation within a 0.6m x 0.6m area around the unit (non-IC rated fixture).



Suitable for fastening on non-flammable surfaces only



Unsuitable for covering by heat insulation material

2. Installation

1. Prepare a circular opening in the lower ceiling (1) as shown in the picture below.

2. Insert the Ambiane unit into the opening. Fasten the fixture by means of two spring fasteners (2) to the opening

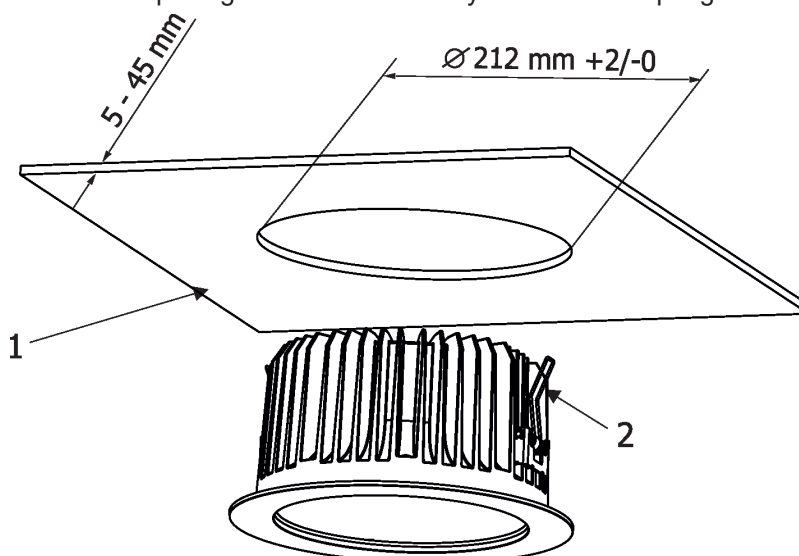

Always switch off power supply of the unit before connecting or disconnecting the unit

To connect needed cables to the fixture, unscrew two screws (4) from the plastic cover (3) and chip needed plastic thin-walled covers (6) off in order to pass cables to the connection blocks (5).

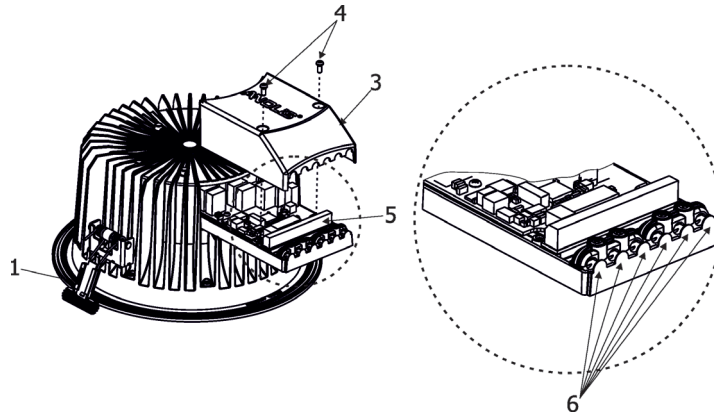

The connection blocks (5) have the following wiring:

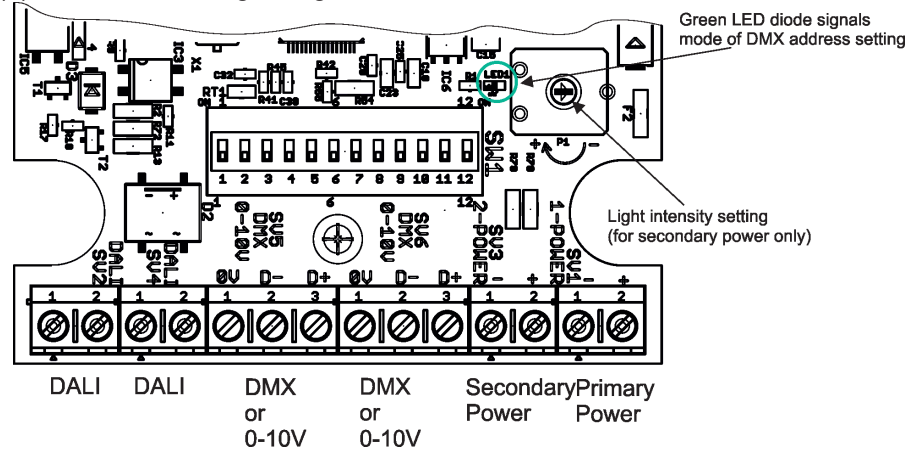

The primary power input serves for a standard power (e.g. ArcPower for Ambiane).
 The secondary power input serves for a backup power(in case that primary power failed).
 If both power inputs are under voltage, the primary power has a priority and the secondary power is disabled.
 If the fixture is supplied via the secondary power, the light output of the fixture is a white colour (3200K) and its light intensity can be set by a trimmer.

The fixture can be controlled by one of the following methods: DMX 512
 0-10V
 DALI

The fixture is equipped with two DMX and DALI connection blocks for easy connection to DMX or DALI chain (In/Out method).

DMX connection

PCB	Function
0V -	Shield
D+	Signal (+)
D-	Signal (-)

0-10V connection

PCB	Function
0V	0V
D+	+10V

Power connection

PCB	Function
+	Power +
-	Power -

3. DMX and DALI address setting and control

The DIP switch, located next to the connection blocks, allows to set a method of control, run test and also allows to switch the fixture to the update mode in case of software update.

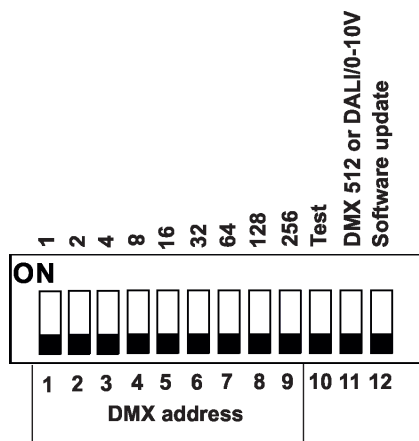

DIP 10 - if switched to ON=test light (the fixture lights at 3200K)
 DIP 11 - selection of fixture control: OFF=DMX 512 or DALI, ON=0-10V
 DIP 12 - change from OFF to ON position switches the fixture to the update mode.

DMX control

The DMX start address, is the first channel used to receive instructions from the DMX controller. The address may be any channel from 1 to 512. DMX address can be set either by DIP switch or by RDM. DMX address set by RDM overwrites address set by DIP switch and vice versa. The green LED on PCB signals way of DMX address setting:

LED lights-DMX address is set by means of the DIP switch.

LED does not light- DMX address is set by means of RDM.

DIP 11 has to be set in OFF position.

Example of DMX addresses:

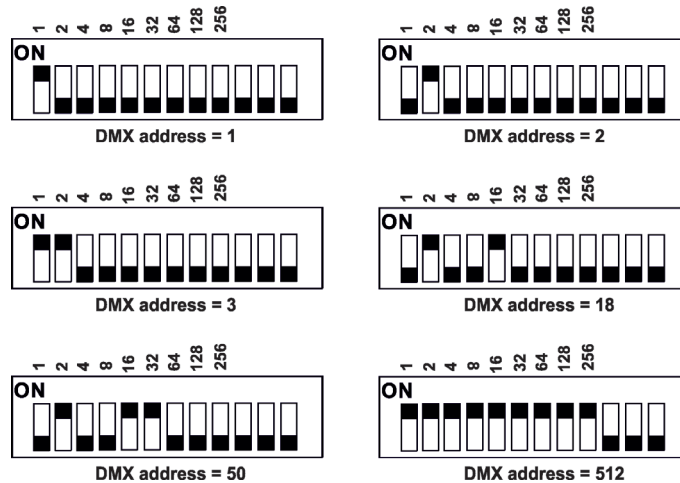

DALI control

Addressing of the fixture is made by means of an external DALI controller. The external DALI controller has to send activating command (8=ON) if you need to start the permanent control of the fixture (fixture will not respond to DMX commands) and deactivating command (0=OFF) to stop control of the fixture.

DIP 11 has to be set in OFF position.

Note: If DIP 11=OFF (fixture is controlled by DMX or DALI), the first coming command switches the fixture to the corresponding operation mode (DMX operation by a DMX command, DALI operation by a DALI command). E.g. the fixture stays in a DALI operation and coming DMX command switches the fixture to DMX operation. Next command is a DALI command and switches the fixture to the DALI operation etc. If you need the permanent DALI operation, you have to send a DALI command 8 to the fixture.

0-10V control

DIP 11 has to be set in ON position. 0-10V operation has priority to DALI commands.

4. RDM

This fixture supports RDM operation. RDM (Remote Device Management) is a bi-directional communication protocol for use in DMX512 control systems, it is the new open standard for DMX512 device configuration and status monitoring.

RDM allows you to set DMX address, select DMX mode and readout software version of the fixture.

5. Anti-glare ring installation

Insert the anti glare ring (1) into the fixture until three locks (2) snap into slots (3).

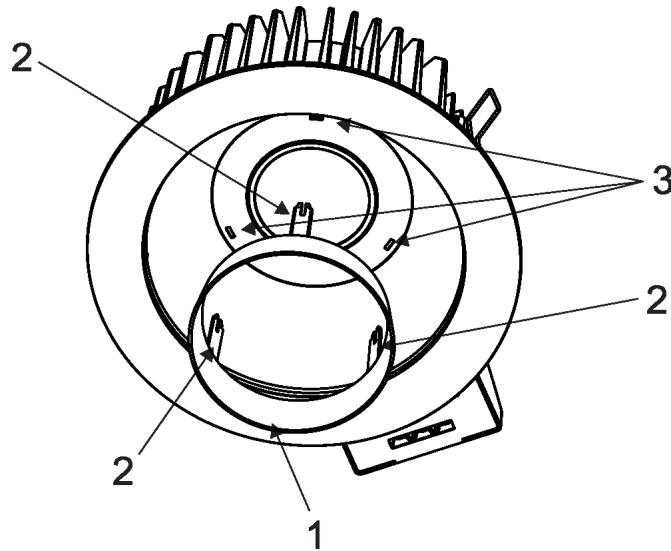

6. Adapter ring installation

1. Remove both spring fasteners (2) by unscrewing the four screws M4x10 (1).

2. Slide the adapter ring (4) onto the housing of the fixture. Screw the new fasteners (3) on the housing. Use original screws M4x10 (1).

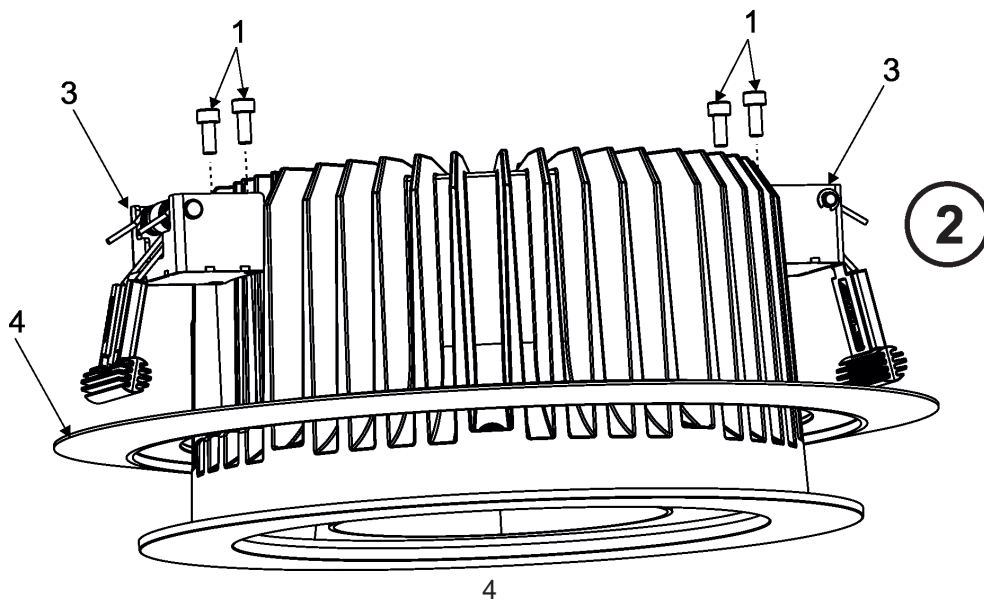
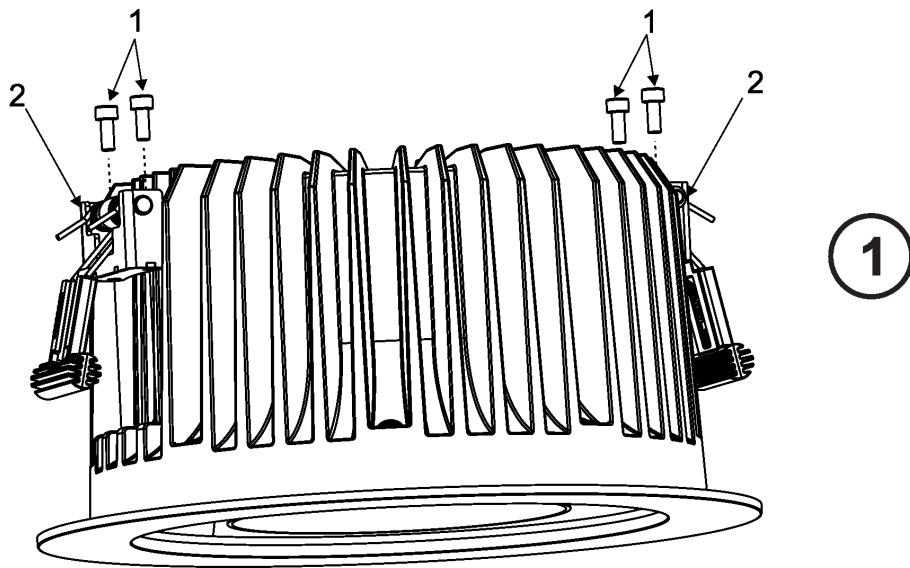

7. DMX protocol

version 1.1

Mode 1 Channel	Mode 2 Channel	Value	Function	Type of control
1	1	0-255	Dimmer Light intensity coarse 0% -->100%	proportional
-	2	0-255	Dimmer Fine Light intensity from min. -->max.	proportional

8. Technical specifications

Input voltage:	24V DC
Max. power consumption:	40W
Protection class:	CE:  (Class III)
Beam angle:	ETL: Class 2 or LVLE 67°, 80° with anti-glare ring
Colour temperature:	3200K
Control:	DMX, DALI, 0-10V, RDM compatible
DMX channels:	1 (Mode 1), 2 (Mode 2)
Typical Lumen maintenance:	70%@ 50,000 hours
Led life expectancy:	minimum 50,000 hours
Operating ambient temp. range:	-20°C/+45°C (-4F/+113F)
Operating temperature:	75°C @ Ambient +35°C (167°F @ Ambient +95°F)
Cooling :	convection
Total heat dissipation:	136 BTU/h (calculated)
Housing:	aluminium
Weight:	1.8 kg
Installation method:	via two spring fasteners
IC rating:	non-IC rated
Power/DMX/DALI connection:	screw connection block Degson DG306-5.0-02P (Wire range: 22-14AWG(UL), 1.5mm ² (IEC))
Max. distance between Ambiane and ArcPower for Ambiane:	1m (for 2 x 18AWG cable)
Protection factor:	IP 20 (without diffuser glass), IP20/IP54 (with Diffuser Glass)

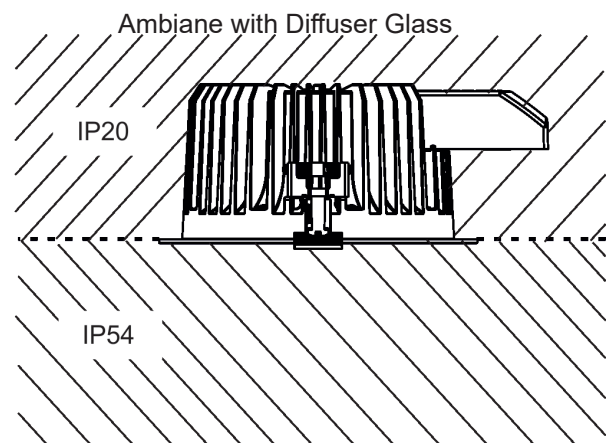
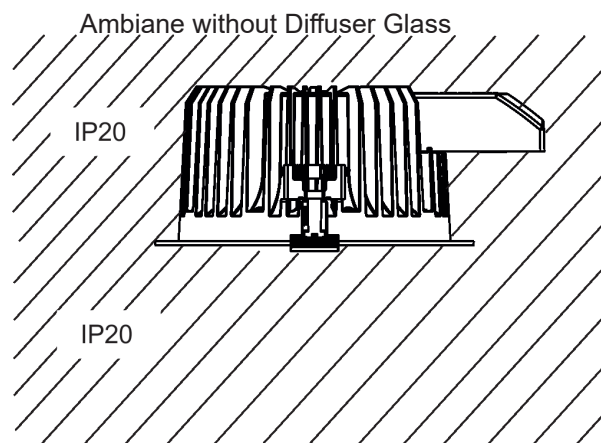

9. Optional Accessories

ArcPower for Ambiane (P/N 10063035)
 Anti-Glare Ring (P/N 10980386)
 Diffuser Glass Frosted (P/N 10980387)
 Adapter Ring (230-255mm) (P/N 10980388)

10. Maintenance

Keep the fixture clean, especially light source and the ribbed housing.

11. Dimensions

mm [inch]

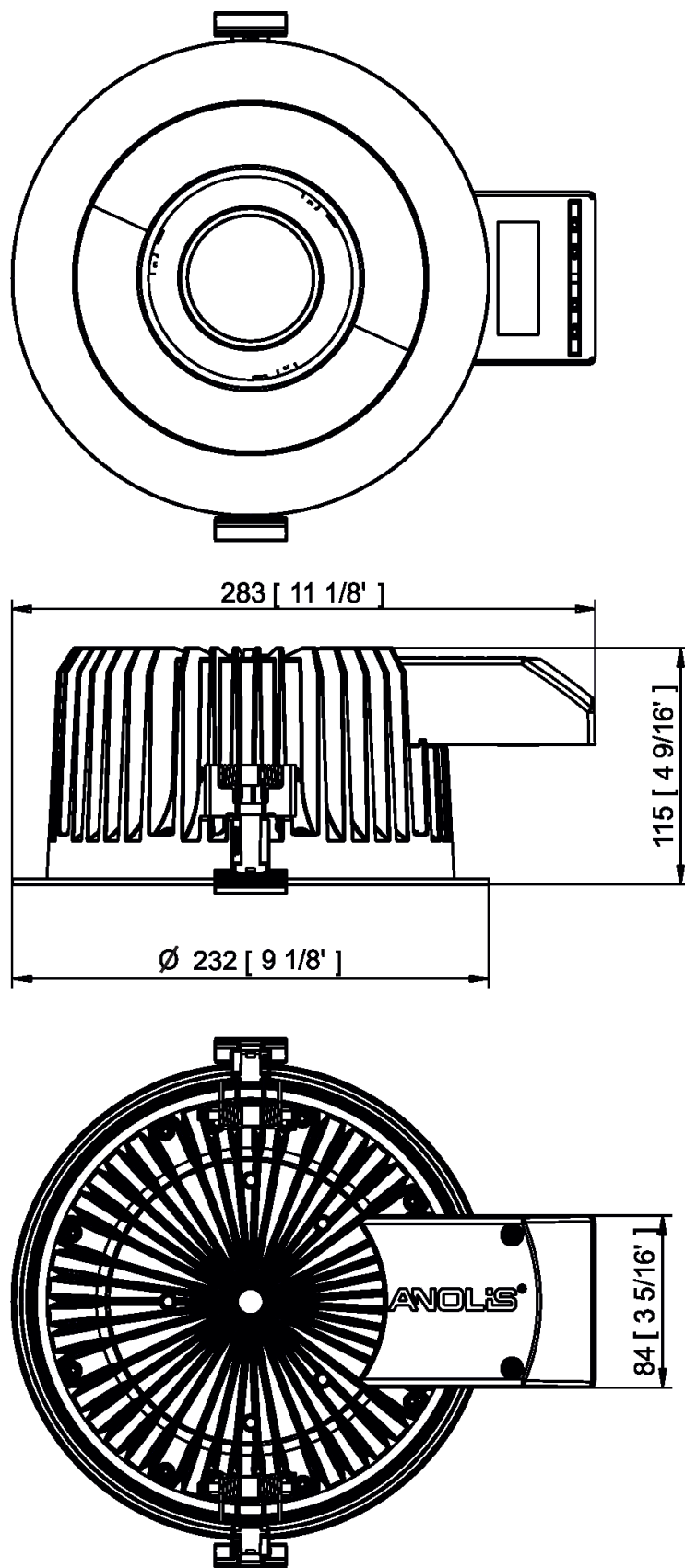

Version 1.9 May 11, 2018

Specifications are subject to change without notice.

Made in CZECH REPUBLIC by ROBE LIGHTING s.r.o. Palackeho 416/20 CZ 75701 Valasske Mezirici