

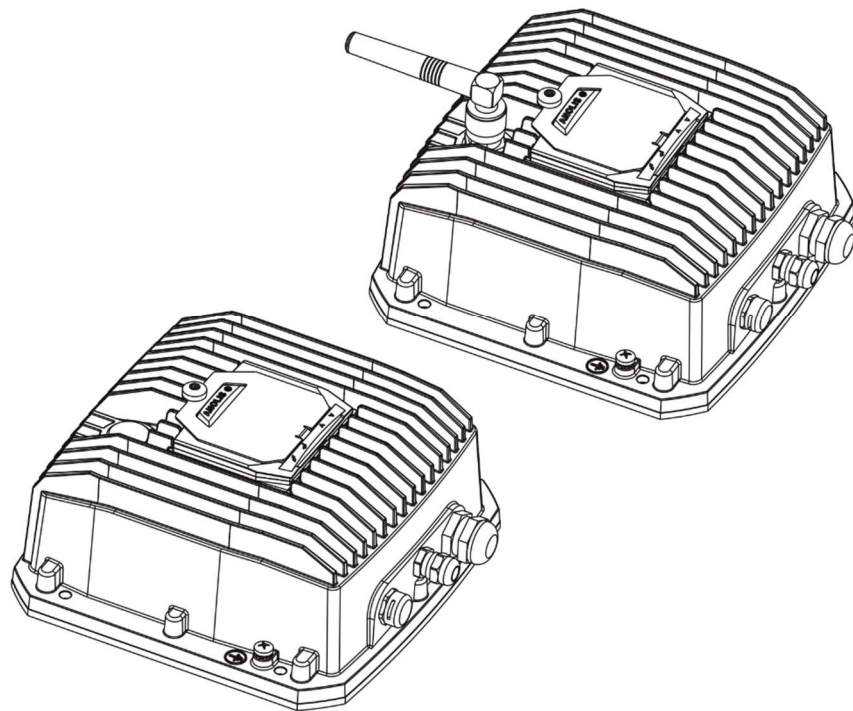

**ArcPower 48 Outdoor**  
**ArcPower 48 Outdoor /W**  
**ArcPower 48 Outdoor US**  
**ArcPower 48 Outdoor US /W**



**USER MANUAL**

Version 1.5

## Table of contents

1. Safety instructions .....	3
2. Fixture exterior view.....	4
3. Installation .....	5
3.1 Mounting the fixture .....	5
3.2 Connection to the mains .....	5
3.3 Wiring of the LED input connector .....	7
4. ArcPower 48 Outdoor (RGBW) - DMX protocol.....	8
4.1 ArcPower 48 Outdoor (RGBA) - DMX protocol.....	9
4.2 ArcPower 48 Outdoor (SmartWhite) - DMX protocol .....	11
4.3 ArcPower 48 Outdoor (Single colour) - DMX protocol .....	12
5. Control menu map.....	13
6. Fixture menu.....	16
6.1 Fixture Address.....	16
6.2 Fixture information.....	16
6.3 Personality .....	17
6.4 Manual mode.....	18
6.5 Test sequences.....	18
6.6 Stand-alone setting.....	18
6.7 Special functions.....	20
7. RDM .....	22
8. Error messages .....	23
9. Wireless DMX operation.....	23
10. Technical specifications .....	23
11. Cleaning and maintenance .....	25

**FOR YOUR OWN SAFETY, PLEASE READ THIS USER MANUAL CAREFULLY  
BEFORE POWERING OR INSTALLING YOUR ArcPower 48 Outdoor !  
Save it for future reference.**

This device has left our premises in absolutely perfect condition. In order to maintain this condition and to ensure a safe operation, it is absolutely necessary for the user to follow the safety instructions and warning notes written in this manual.

The manufacturer will not accept liability for any resulting damages caused by the non-observance of this manual or any unauthorized modification to the device.

Please consider that damages caused by manual modifications to the device are not subject to warranty.

## 1. Safety instructions

**DANGEROUS VOLTAGE CONSTITUTING A RISK OF ELECTRIC SHOCK IS PRESENT WITHIN THIS UNIT!**

This fixture should be operated only from the type of power source indicated on the marking label. If you are not sure of the type of power supplied, consult your authorized distributor or local power company.

Always disconnect the fixture from AC power before cleaning, removing or installing the fuses, or any part.

Do not overload wall outlets and extension cords as this can result in fire or electric shock.

Make sure that the power cord is never crimped or damaged by sharp edges. Check the fixture and the power cord from time to time.

Do not install the unit near naked flames.

During the operation the housing becomes hot (up to 80°C)

Refer servicing to qualified service personnel.

**This fixture falls under protection class I. Therefore this fixture has to be connected to a mains socket outlet with a protective earthing connection.**

Do not connect this fixture to a dimmer pack.

Keep combustible materials at least 20 cm away from the fixture.

If the fixture has been exposed to drastic temperature fluctuation (e.g. after transportation), do not switch it on immediately. The arising condensation water might damage your device. Leave the device switched off until it has reached room temperature.

Avoid brute force when installing or operating the fixture.

The fixture was designed for outdoor use. This fixture must not be used for underwater installation.

When choosing the installation spot, please make sure that the fixture is not exposed to extreme heat or dust.

Avoid using the unit in locations subject to possible impacts.

The fixture body never must be covered with cloth or other materials.

Only operate the fixture after having checked that the housing is firmly closed and all screws are tightly fastened.

Make sure that the area below the installation place is blocked when rigging, derigging or servicing the fixture.

The fixture becomes very hot during operation. Allow the fixture to cool approximately 30 minutes prior to manipulate with it.

Operate the fixture only after having familiarized with its functions. Do not permit operation by persons not qualified for operating the fixture. Most damages are the result of unprofessional operation!

Do not attempt to dismantle or modify the unit.

Please consider that unauthorized modifications on the fixture are forbidden due to safety reasons!

Please use the original packaging if the fixture is to be transported.

If this device will be operated in any way different to the one described in this manual, the product may suffer damages and the guarantee becomes void. Furthermore, any other operation may lead to dangers like short-circuit, burns, electric shock etc.

## 2. Fixture exterior view

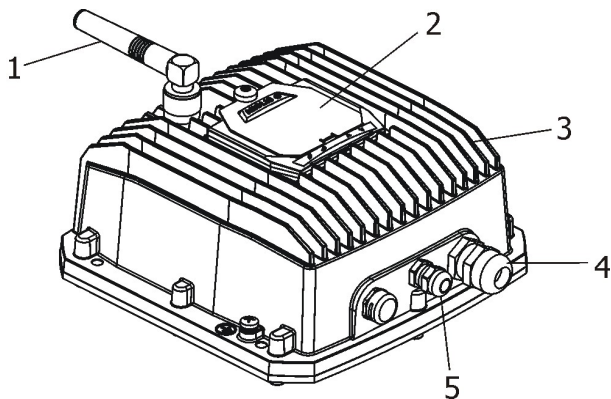

- |  |
|--|
| <ol style="list-style-type: none"><li>1. Antenna (only wireless DMX version)</li><li>2. Control board with anti-vandal cover</li><li>3. Housing</li><li>4. Power/data input</li><li>5. LED input</li></ol> |
|--|

### 3. Installation

**Note**

1. *Before connecting a LED module, check its technical data in order to set the correct LED current and find out if the LED module includes a temperature sensor. See the ArcPower 48 outdoor menu "Personality" → "Load" and "Personality" → "Temp Sen".*
2. *Do not overload the ArcPower 48 Outdoor.*
3. *Only one LED module with the temperature sensor can be connected to the ArcPower 48 Outdoor.*
4. *Mixing LED modules without temperature sensor and with temperature sensor is not allowed.*
5. *Max. length of connection cable between the ArPower 48 Outdoor and the LED unit should not exceed 20 metres.*

#### 3.1 Mounting the fixture

The ArcPower 48 Outdoor can be arranged in any position orientation.

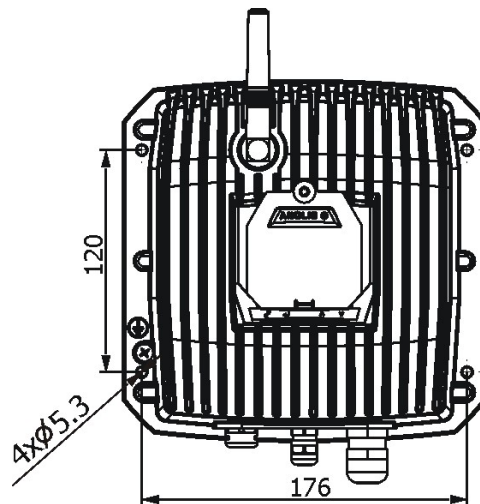

Four holes with diameter of 5.3mm in the control unit are intended for mounting on a flat, non-flammable surface. The length of the connection cable between the ArcPower 48 Outdoor and the LED unit should not exceed 20 m (at 700mA load) or 80m (at 350mA load).

**Warning for wireless DMX version of the ArcPower 48 Outdoor!**  
*The fixture is supplied with the cap screwed on the antenna connector. This cap provides declared IP rating of the fixture but when the cap is removed, the enclosed antenna must be installed on the fixture to keep declared IP rating of the fixture!*

#### 3.2 Connection to the mains

**Fixtures must be installed by a qualified electrician in accordance with all national and local electrical and construction codes and regulation.**

The ArcPower 48 Outdoor is equipped with a 5-cored power/data cable. The 3 cores serve for the power supply (3 x 1.5mm<sup>2</sup>) and next 2 shielded cores are intended for DMX connection as shown in the table.

Core	Connection	Core	Connection
Black	Live	Red	Data +
Blue	Neutral	White	Data -
Yellow/Green	⊕	Shielding	0

## ArcPower 48 Outdoor

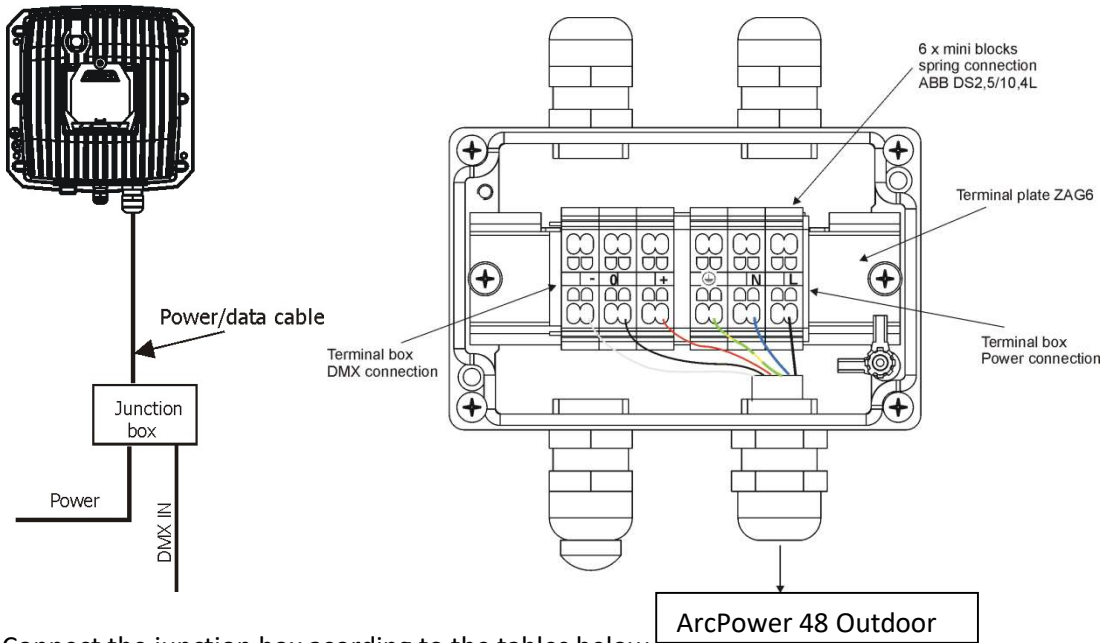

Connect the junction box according to the tables below

### Power connection

	L	N	⊕
EU	Braun	Blue	Green/yellow
US	Black	White	Green

Do not overload the supply line and the connecting leads.

### DMX connection

+	0	-
Data +	Data ground(shielding)	Data -

Remove end caps from cable glands before passing cables into the junction box. The four cable glands M20 with standard seals serve for cable of diameter of 6-12mm, for smaller diameter of cable (4-8mm) you have to remove original sealing from the cable gland M20 and use the enclosed reducing seal instead it. Four reducing seals for diameter of cable 4-8mm (P/N 13051388) are enclosed.

Fully tighten cable gland nuts and check that cables are properly fastened in the cable glands.

**Note:** To keep declared IP rating, every cable gland has to be covered with the end cap if this cable gland is not used for cable passing.

Screw the cover of the junction box and check that it is fully tighten.

# ArcPower 48 Outdoor

Cable gland M20 MS (P/N 13051206)

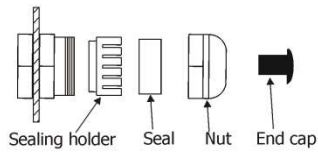

**4 x Standard seal** - part of cable gland M20 MS  
(for diameter of cable: 6-12mm)

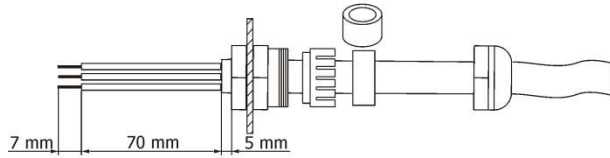

**4 x Reducing seal** (P/N 13051388) - enclosed, standard seal has to be removed before installing this seal  
(for diameter of cable: 4-8mm)

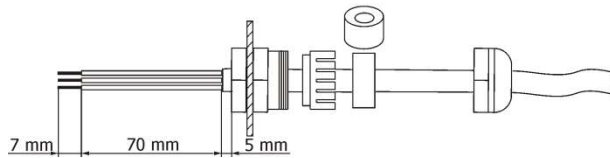

## 3.3 Wiring of the LED input connector

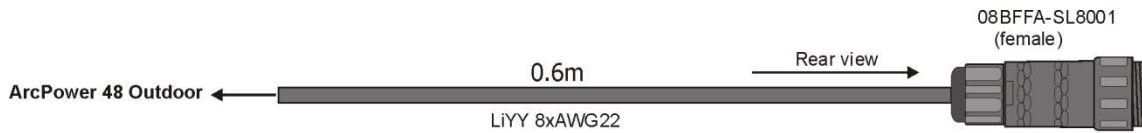

- 1 - R- ...orange
- 2 - + ...brown
- 3 - W- ...blue
- 4 - B- ...red
- 5 - + ...black
- 6 - G- ...white
- 7 - + ...yellow
- 8 - T\* ...green

\* Temperature sensor

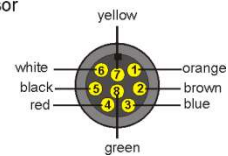
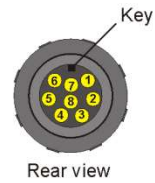







ArcPower 48 Outdoor

				248-251 252-255	Rainbow effect with fade time (fast →slow) Rainbow effect without fade time (fast →slow)	proportional proportional
-	-	-	7	0-31 32-63 64-95 96-127 128-143 144-159 160-191 192-223 224-255	<b><u>Shutter/ Strobe</u></b> Shutter closed Shutter open Strobe-effect from slow to fast Shutter open Opening pulses in sequences slow--> fast Closing pulses in sequences fast --> slow Shutter open Random strobe-effects from slow to fast Shutter open	step step proportional step proportional proportional step proportional step
2	-	-	8	0 - 255	<b><u>Dimmer</u></b> Dimmer intensity from 0% to 100%	proportional
-	-	-	9	0 - 255	<b><u>Dimmer fine</u></b> Fine dimmer intensity from low to high	Proportional

## 4.2 ArcPower 48 Outdoor (SmartWhite) - DMX protocol

Version 1.0

Mode/Channel			Value	Function	Type of control
1	2	3			
1	-	1	0 - 255	<b>Warm white LEDs</b> Warm white LEDs saturation control (0-100%)	proportional
2	-	2	0 - 255	<b>Cool white LEDs</b> Cool white LEDs saturation control (0-100%)	proportional
-	1	3	0 1-2 3-4 5-6 7-8 9-10 11-12 13-14 15-16 17-247 248 249 250-255	<b>Colour wheel</b> No function White 2800 K White 3200 K White 3800 K White 4200 K White 4600 K White 5000 K White 5600 K White 6300 K Warm white --> Cool white Rainbow effect (with fade time) Rainbow effect Reserved	 step step step step step step Step step proportional step step
-	-	4	0-31 32-63 64-95 96-127 128-143 144-159 160-191 192-223 224-255	<b>Strobe</b> Shutter closed Shutter open Strobe-effect from slow to fast Shutter open Opening pulses in sequences slow--> fast Closing pulses in sequences fast --> slow Shutter open Random strobe-effects from slow to fast Shutter open	 step step proportional step proportional proportional step proportional step
-	2	5	0 - 255	<b>Dimmer</b> Dimmer intensity from 0% to 100%	proportional
-	-	6	0 - 255	<b>Dimmer fine</b> Fine dimmer intensity from low to high	proportional

### 4.3 ArcPower 48 Outdoor (Single colour) - DMX protocol

Version 1.0

Mode/Channel		Value	Function	Type of control
1	2			
-	1	0-31 32-63 64-95 96-127 128-143 144-159 160-191 192-223 224-255	<b><u>Strobe</u></b> Shutter closed Shutter open Strobe-effect from slow to fast Shutter open Opening pulses in sequences slow--> fast Closing pulses in sequences fast --> slow Shutter open Random strobe-effects from slow to fast Shutter open	step step proportional step proportional proportional step proportional step
1	2	0 - 255	<b><u>Dimmer</u></b> Dimmer intensity from 0% to 100%	proportional
-	3	0 - 255	<b><u>Dimmer fine</u></b> Fine dimmer intensity from low to high	proportional

## 5. Control menu map

Default settings=**Bold print**

Menu Level 1	Menu Level 2	Menu Level 3	Menu Level 4	Menu Level 5	Menu Level 6
DMXA 0001	Set DMXA	0001-0512			
InFo	POn Time.	Total			
		Reset			
	DMX In	REd	0-255		
		:			
		Dimmer F	0-255		
	Temp.	Current	Led		
			Board		
		Highest	Led		
			Board		
		High Res.	Led		
			Board		
	Sw Ver.	IC-1			
		IC-2			
PErS	DMX Pres	Mod.1			
		Mod.2			
		<b>Mod.3</b>			
		Mod.4			
	DMX In	<b>Wired</b>			
		Wireless			
		Analog 0-10V			
	M. FTime	<b>0.1-25.5</b>			
	Display	Turn			
		On/Off T	On, <b>Off</b>		
		Contrast	0-100%		

ArcPower 48 Outdoor

		Backlight	0-100%		
Menu Level 1	Menu Level 2	Menu Level 3	Menu Level 4	Menu Level 5	Menu Level 6
	Load	350mA, 700mA			
	Temp Uni	°C, °F			
	Temp Sen	yes,no			
	I Ef Pos	Red	0-255		
		Green	0-255		
		Blue	0-255		
		White	0-255		
		CTC	0-255		
		C Wheel	0-255		
		Strobe	0-255		
		Dimmer	0-255		
		Dimmer F	0-255		
		Store			
	Defaults				
Manual	Red	0-255			
	:	:			
	Dimmer F	0-255			
Test Prg					
St Alone	Auto Run	<b>Off</b>			
		Test			
		Prog 1			
		:			
		Prog 3			
	Pr Play	Test Prg			
		Prog 1			
		:			
		Prog 3			

ArcPower 48 Outdoor

	Pr Edit	Prog 1	Step 01	Prg End	1-40
Menu Level 1	Menu Level 2	Menu Level 3	Menu Level 4	Menu Level 5	Menu Level 6
		:	:	Red	0-255
		Prog 3	Step 40	:	:
				S.Tim.	0-25.5 sec
				F.Tim.	0-25.5 sec
				Copy	
Special	rdM Low				
	rdM High				
	LED type	RGBW			
		Sin. Col.			
		Smart. W.			
	Wireless	Stat, Unlink			
	IniBlink	On, <b>Off</b>			
	Hold DMX	On, <b>Off</b>			
	Flicker freeM	On, <b>Off</b>			
	Adjust	DMX Val	Red	0-255	
			:		
			Dimmer F	0-255	
		Cal Col	Red C	0-255	
			:		
			Store		
		Cal.temp	2700K		
				Red C	0-255
				:	
				Whi C	0-255
				Store	
			3200K		
			4200K		
			5600K		
			8000K		
			Cal.Def.		

	Sw Upd	No/Yes			
--	--------	--------	--	--	--

## 6. Fixture menu

The control panel menu allows to set the fixture according to your needs, obtain information on its operation and manual control of all effects.

The four control buttons on the front have the following functions:

- ↖ - **ESCAPE** button-leaves menu without saving changes.
- ↵ - **ENTER** button- enters menu, confirms adjusted values and leaves menu.
- ▲ - **UP** and ▼ - **DOWN** buttons - move between menu items on the same level, sets values.

### 6.1 Fixture Address

**DMXA  
0001**

Use this menu to set the DMX address of the fixture.

**Set DMXA** --- **Set DMX address**. Select this submenu to set a DMX start address.

To set a DMX address.

1. Use the UP/DOWN buttons to find “ **DMXA/0001** ” menu.
2. Press the ENTER button.
3. Use the UP/DOWN buttons to select desired start address.
4. Press the ENTER button to confirm the choice.

**Note:** After switching on, the ArcPower 48 Outdoor will automatically detect whether DMX 512 data is received or not.

If there is no data received at the DMX input, the display will start to flash with actually set address.

### 6.2 Fixture information

**Info**

Use this menu to read useful information about the fixture status.

To display desired information.

1. Use the UP/DOWN buttons to find the “ InFo ” menu.
2. Press the ENTER button.
3. Use the UP/DOWN buttons to select the required menu item.
4. Press the ENTER button to confirm the choice.

**Pon Time** ---**Power On Time**. Use the menu item to read the number of operation hours of the fixture.

**Total** - the function shows the total number of the operation hours since the ArcPower 48 Outdoor has been fabricated.

**Reset** - the function shows the number of the operation hours that the ArcPower 48 Outdoor has been powered on since the counter was last reset.

In order to reset this counter to 0 you have to press and hold the UP and DOWN buttons and at the same time press the ENTER button.

**DM In** ---**DMX values**. Select this function to read DMX values of each channel received by the fixture.

**Temp** ---**Fixture Temperatures**. Select this menu to read the temperatures:

**Current** --- the current temperature of the LED driver/LED module.

**Highest** - the menu item shows the max. temperatures of the LED driver/LED module since the ArcPower 48 Outdoor has been fabricated.



**High Res.** --- the menu item shows the maximum temperatures of the LED driver/LED module since the counter was last reset. In order to reset this counter to 0 you have to press and hold the UP and DOWN buttons and at the same time press the ENTER button.

Measuring points: Led- a temperature inside the connected LED module  
Board- a temperature inside the ArcPower 48 Outdoor

**In case that LED module does not include temperature sensor, the sign "N/A" will be displayed.**

Note: The ambient temperature should not exceed 40°C.

The temperatures can be displayed in either °C or °F units - see option "tEM.U" in the menu "Pers".

**Sw Ver** --- **Software Versions.** Select this function to read the software version of the fixture processors.

## 6.3 Personality

### Pers

Use this menu to modify the ArcPower 48 Outdoor operating behaviour.

**DMX Pres** --- **DMX preset.** Select this menu item to set a desired DMX mode. Please refer to the chapter "DMX protocol" for detail description of each DMX mode.

**DMX In** --- **DMX input.** Use the menu to select mode of receiving DMX signal:

**Wired** - DMX signal is received by means of the standard DMX cable.

**Wireless** - DMX signal is received by means of the inbuilt wireless module (wireless DMX version only).

**Analog 0-10V** --- Analog dimmer. If this option is selected, the dimmer channel can be controlled via DC voltage (0-10V) connected between pins 1 (data ground) and 3 (Data +) of DMX input of the fixture (0-data ground, 10V-data +).

Procedure of setting:

1. Set fixture's channels at desired values (by means of menu item Init Effect Positions "I. Ef.Pos").
2. Disconnect DMX controller
3. Select option "Analog 0-10V" from menu DMX input
4. Connect DC voltage to the DMX input of the fixture

**M FTime** --- **Max. Fade time.** Select this menu item to set a desired max. fade time (0-25.5 sec.). This adjusted fade time influences fade of Red, Green, Blue, White and dimmer during DMX operation:

If time between two receiving DMX values is > than fade time set in the item "M Ftime", the entire adjusted fade time will be used.

If time between two receiving DMX values is < than fade time set in the item "M Ftime", the adjusted fade time will be reduced to fill entire time between the two receiving DMX values.

e.g "M Ftime"=2sec. and fixture has received Red=0 DMX, after 5 seconds will receive Red=255 DMX. It means, that red will go to full intensity during 2 seconds.

"M Ftime"=8 sec. and fixture has received Red=0 DMX, after 5 seconds will receive Red=255 DMX. It means, that red will go to full intensity during 5 seconds. (Max, fade time is reduced from 8 sec. to 5 sec.).

**Display.** --- **Display adjusting.** This function allows you to change the display settings.

**Turn** - This function turns the display by 180°.

**On/Off T** - This function allows you to keep the display permanent on or turn it off two minutes after last pressing any button on the control panel.

**Contrast** - Use this function to adjust contrast of the display (0-100%).

**Backlight** - Use this function to adjust backlight of the display (0-100%).

**Load** --- **Current load.** This function allows you to set desired current for connected LED module:

**350 mA**

**700 mA**

See technical information about LED module before connecting it to the driver!

**Temp Uni** --- **Temperature Unit.** Use this menu in order to display the fixture temperatures in desired units: °C or °F.

**Temp Sen** --- **Temperature sensor.** If this function is On, the ArcPower 48 Outdoor measures inside temperature of the connected LED module and according to the temperature reduces LED current to prevent overheating of the LED module. The LED module has to be equipped temperature sensor. If a LED module is without temperature sensor, this option must be set Off.

Note: in case that Temp Sen=On and the connected LED module is without a temperature sensor, the following error message will appear "Temp Sen Error". To cancel this message, set Temp Sen=Off.

**I Ef Pos** --- **Init effect positions.** Use this function to set all effects to the desired positions to which they will move after switching the fixture on (if DMX is not being received).

**Defaults** --- **Default Settings .**The menu item sets all fixture parameters to the default (factory) values.

## 6.4 Manual mode

### Manual

Use this menu for control the fixture without connected DMX console.

To control fixture channels.

1. Use the UP/DOWN buttons to find " Manual" menu.
2. Press the ENTER button.
3. Use the UP/DOWN buttons to select desired effect (channel).

List of control channels:

"Red" - red LEDs saturations

"Green" - green LEDs saturations

"Blue" - blue LEDs saturations

"White" - white LEDs saturations

"C TC" - a colour temperature correction

"C Wheel" - a virtual colour wheel

"Strobe"- a strobe, shutter

"Dimmer"- a dimmer

"Dimmer F" a fine dimmer

4. Press the ENTER button and use the UP/DOWN buttons to set value , press the ENTER button to confirm it.

## 6.5 Test sequences

### Test Prog

Use this menu to run demo-test sequences without an external controller, which will show you some possibilities of using the ArcPower 48 Outdoor .

## 6.6 Stand-alone setting

### Sta Alone

The fixtures on a data link are not connected to the controller but can execute pre-set programs which can be different for every fixture.

**Auto Run --- Automatic playback.** This function allows you to select the program which will be played after switching the fixture on. Selected program will be played continuously in a loop.

1. Use the UP/DOWN buttons to find “**Sta Alone**” menu.
2. Press the ENTER button.
3. Use the UP/DOWN buttons to select “**Auto Run**” item.
4. Press the ENTER button.
5. Use the UP/DOWN buttons to select desired program.
6. Press the ENTER button to confirm the choice.

**Pr Play --- Playing program.** By enter to this menu a complete overview of all programs is offered, from which the program to be run can be selected.

1. Use the UP/DOWN buttons to find “**Pr Play**” menu.
2. Press the ENTER button.
3. Use the UP/DOWN buttons to select desired program.
4. Press the ENTER button. The selected program runs in a loop.

**Pr Edit --- Editing a program.** The fixture offers 3 freely editable programs (Prog.1-Prog.3) each up to 40 steps. Every program step includes a fade time-the time taken by the step’s channel status to reach the desired level and a step time-the total time occupied by the step in the program.

E.g. If “F.tim.”=5 second and “S.tim.”=20 second, effects will go to the desired position during 5 seconds and after that they will stay in this position for 15 seconds before going to the next prog. step

1. Use the UP/DOWN buttons to find “**Sta Alone**” menu and press the ENTER button.
2. Use the UP/DOWN buttons to select “**Pr Edit**” menu and press the ENTER button.
3. Use the UP/DOWN buttons to select a program you want to edit (Prog.1-Prog.3) and press ENTER button.
4. Use the UP/DOWN buttons to select a desired program step ("Step 01" - "Step 40") and press ENTER button.
5. Use the UP/DOWN buttons to select a channel you want to edit and press the ENTER button.

List of editable items:

“Prg.En” - a total number of program steps (value 1-40). This value should be set before start programming (e.g. if you want to create program with 10 steps, set Prg.En=10).

“Red” - red LEDs saturations

“Green” - green LEDs saturations

“Blue” - blue LEDs saturations

“White” - white LEDs saturations

“C TC” - a colour temperature correction

“C Wheel” - a virtual colour wheel

“Strobe”- a strobe, shutter

“Dimmer”- a dimmer

“Dimmer F” a fine dimmer

“F.tim.”- a fade time, (0-25.5) seconds

“S.tim.”- a step time, value (0-25.5) seconds

“COPY”. – this item duplicates the current prog. step to the next prog. step. The item “Prg En” is increased automatically.

6. Use the UP/DOWN buttons to set a DMX value of the channel and then press the ENTER button.
7. Use the UP/DOWN buttons to select next channel and press the ENTER button.
8. After having set all channels in the current program step, press the MODE button to go by one menu level back and select another program step.

## 6.7 Special functions

### Special

**rdM Low** --- **RDM Code**. This menu item shows the first part of the RDM identification code.

**rdM High** --- **RDM Code**. This menu item shows the second part of the RDM identification code.

**LED type** --- **LED colour variant**. This menu allows to set desired colour variant according to connected LED module.

**RGBW** – RGBW variant.

**Sin. Col.** – Single colour variant.

**Smart W.** – Smart white variant.

**RGBA** – RGBAmber variant.

**Note: The menu items and DMX chart will be changed according to set colour variant!**

**Wireless** --- **Wireless state**. This menu serves for reading of the state of wireless operation (only Wireless DMX).

**Unlink** - The item serves for unlinking the fixture from the transmitter (only Wireless DMX version)

**IniBlink** --- **Initial blink**. If this function is on, the fixture makes auto-calibration (each LED colour lits on 100% for short time) after switching the fixture on.

**HoLd DMX** --- If the function is on, the last received DMX values are held in case, that DMX data receiving was interrupted (e.g. disconnected DMX controller).

**Flicker Free M** --- **Flicker free mode**. If the function is on, the light flickering visible in cameras is corrected but colour uniformity is worse.

**Adjust** - **Adjustment**. The menu allows the fine adjustment of colours.

**DMX Val**- **DMX values**. Use the menu to set DMX values of fixture's channels.

**Cal Col** - A calibration of red, green, blue and white colours by means of an automatic calibration with a factory equipment.

**Red C** – red LEDs saturation (0-255)

**Grn C** – green LEDs saturation (0-255)

**Blu C** – blue LEDs saturation (0-255)

**Whi C** – white LEDs saturation (0-255)

**Cal Temp** – Selection of colour temperature for manual calibration: 2700K, 3200K, 4200K, 5600K, 8000K.

Manual colour calibration:

1. Connect the fixture to the mains, go to the "Manual" menu and set the shutter, dimmer, red, green, blue and white channel at 255 DMX and let the LED module heat up (cca 1 hour).
2. Go to the "Manual" menu and set the C Wheel at 1 DMX (2700K)
3. Go to the "CalCol" menu, select "2700K" item and by means of the Red C, Green C, Blue C and White C items adjust the 2700K colour temperature as exactly as possible ( $\Delta u'v' = 0$ ). After calibration, press the "Store" item to save adjusted values.
4. Go to the "Manual" menu and set the C Wheel at 4 DMX (3200K).
5. Go to the "CalCol" menu, select "3200K" item and by means of the Red C, Green C, Blue C and White C items adjust the 3200K colour temperature as exactly as possible ( $\Delta u'v' = 0$ ). After calibration, press the "Store" item to save adjusted values.
6. Repeat this procedure for rest of colour temperatures (4200K, 5600K, 8000K).

**SW Upd --- Software update.** The menu item allows you to update software in the fixture via either serial or USB port of PC.

The following are required in order to update software:

- PC running Windows /7/8/10 or Linux
- DMX Software Uploader
- Flash cable RS232/DMX No.13050624 (if you want to use a serial port of PC)
- Robe Universal Interface (if you want to use an USB port of PC)

Note1: Software update should execute a qualified person. If you lack qualification, do not attempt the update yourself and ask for help your Anolis distributor.

Note 2: DMX address, programs and all items in the menu "PErS" will be set to their default values.

**To update software in the fixture:**

**I. Installation of the DMX Software Uploader.**

1. DMX Software Uploader program is available from the Anolis web site at WWW.anolis.cz.
2. Make a new directory ( e.g. Anolis\_Uploader) on your hard disk and download the software into it.
3. Unpack the program from the archive.

**II. Fixture software updating.**

1. Determine which of your port is available on your PC and connect it:
  - with the DMX input of the fixture if you using the flash cable RS232/DMX
  - with the DMX input of the Robe Universal Interface if you using the USB cable.

Disconnect the fixture from the other fixtures in a DMX chain. Turn both the computer and the fixture on.

2. Switch the fixture to the updating mode:
  - 1 Use the UP/DOWN buttons to find "SPEC." menu.
  - 2 Press the ENTER button.
  - 3 Use the UP/DOWN buttons to select " uPd." item.
  - 4 Press the ENTER button
  - 5 Use the UP/DOWN buttons to select " yES" option
  - 6 Press the ENTER button

Note: If you do not want to continue in software update, you have to switch off and on the fixture to escape from this menu.

3. We recommend to cancel all running programs before start of the Software Uploader.
4. Run the Software Uploader program. Select desired COM and then click on the Connect button.

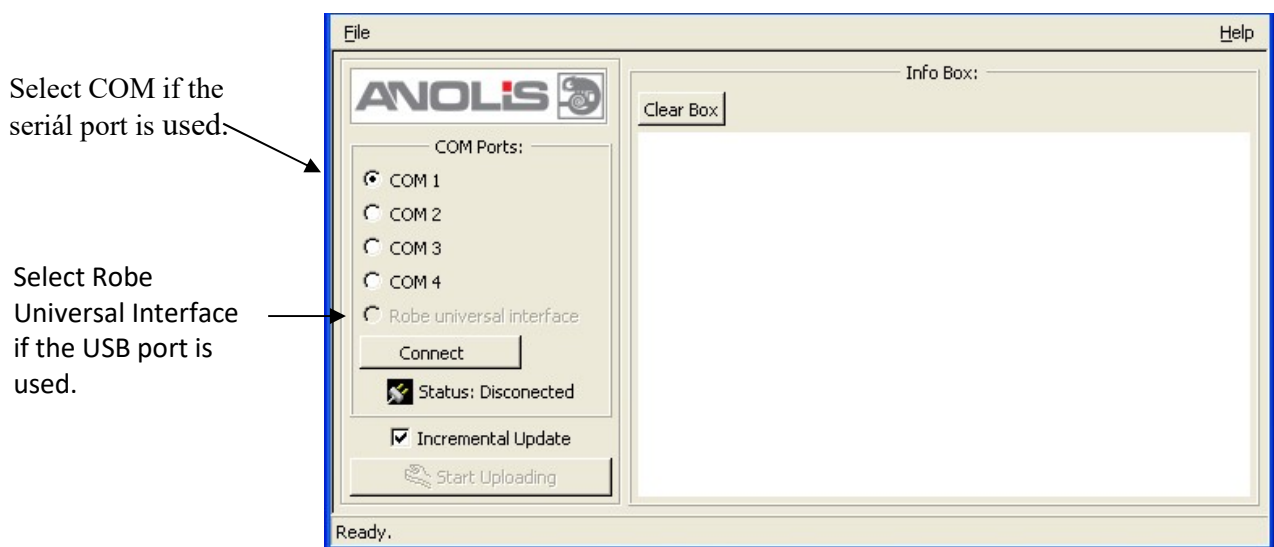

If the connection is OK, click on the Start Uploading button to start uploading. It will take several minutes to perform software update. If the option "Incremental Update" is not checked, all processors will be updated (including processors with the same software version). If you wish to update only later versions of processors, check the Incremental Update box.

Avoid interrupting the process. Update status is being displayed in the Info Box window.

When the update is finished, the line with the text “The fixture is successfully updated” will appear in this window and the fixture will reset with the new software.

**Note:** In the case of an interruption of the upload process (e.g. power cut), the fixture keeps the updating mode and you have to repeat the software update again.

For example: The fixture was switched off before finishing software upload. After switching again the fixture on, the fixture is still in the updating mode and the display is dark. Restart the Software Uploader program and repeat software update from your PC.

## 7. RDM

This fixture is ready for RDM operation. RDM (Remote Device Management) is a bi-directional communications protocol for use in DMX512 control systems, it is the new open standard for DMX512 device configuration and status monitoring.

The RDM protocol allows data packets to be inserted into a DMX512 data stream without adversely affecting existing non-RDM equipment. By using a special „Start Code,“ and by complying with the timing specifications for DMX512, the RDM protocol allows a console or dedicated RDM controller to send commands to and receive messages from specific moving lights.

RDM allows explicit commands to be sent to a device and responses to be received from it.

The list of commands for ArcPower 48 Outdoor is the following.

Parameter ID	Discovery command	SET command	GET command
DISC_UNIQUE_BRANCH	*		
DISC_MUTE	*		
DISC_UN_MUTE	*		
DEVICE_INFO			*
SUPPORTED_PARAMETERS			*
SOFTWARE_VERSION_LABEL			*
DMX_START_ADDRESS		*	*
IDENTIFY_DEVICE		*	*
DEVICE_MODEL_DESCRIPTION			*
MANUFACTURER_LABEL			*
DEVICE_LABEL		*	*
SENSOR_DEFINITION			*
SENSOR_VALUE			*
DISPLAY_LEVEL		*	*
DEVICE_RESET		*	
DMX_PERSONALITY		*	*
DMX_PERSONALITY_DESCRIPTION			*
STATUS_MESSAGES			*

STATUS_ID_DESCRIPTION			*
DEVICE_HOURS			*

Please, see the Robe Universal Interface user manual for detail description of RDM operation.

## 8. Error messages

**Temp Sen Error** – Connected LED module does not include temperature sensor, but the option “Temp Sen” is On. Set this option to Off (Personality →Temp Sen).

## 9. Wireless DMX operation

The wireless version of the ArcPower 48 Outdoor (ArcPower 48 Outdoor /W) is equipped with the Lumen Radio CRMX module and antenna for receiving DMX signal. CRMX module operates on the 2.4 GHz band.

1. Select wireless DMX input from the menu **PErS** (PErS-->dMX In-->Wireless).
2. To link the fixture with DMX transmitter.  
The fixture can be only linked with the transmitter by running the link procedure at DMX transmitter . After linking , the level of DMX signal ( 0-100 %) is displayed in the menu **Special** (Special-->Wireless-->Stat).
3. To unlink the fixture from DMX transmitter.  
The fixture can be unlinked from receiver via the menu **Special** (-->Wireless-->Unlink).

## 10. Technical specifications

### Power supply

- Electronic auto-ranging
- Input voltage (CE): 100 - 240V AC, 50-60 Hz
- Input voltage (US): 100 - 277V AC, 50-60 Hz
- Max. power consumption: 130W (power factor=0.93, I=0.55A at 230V)

### Light effects

- RGBW colour mixing
- Virtual colour wheel
- Adjustable strobe sequences
- White colour balance adjusting

### Load

- Max. output current: 350mA or 700 mA per colour (channel)
- Max. load (only one option):
  - 12 x 10W RGBW multi-chip LEDs
  - 48 LEDs@ 700mA (max. 12 LEDs per colour)
  - 48 LEDs @ 350mA (max. 12 LEDs per colour)

### Control

- Protocol: USITT DMX 512, RDM
- DMX modes: 4 (2,3,4,9 control channels)
- Operation modes: DMX, Stand-alone
- Setting and addressing: Two-row LCD display & control buttons or via RDM
- 3 user editable programs each up to 40 steps.

## ArcPower 48 Outdoor

### **Wireless DMX/RDM module** (for wireless DMX version only – ArcPower 48 Outdoor /W, ArcPower 48 Outdoor US /W )

- Compliance with USITT DMX-512 (1986 & 1990) and 512-A
- Full DMX fidelity and frame integrity
- Auto sensing of DMX frame rate and frame size
- <5ms DMX latency
- Operational frequency range of 2402-2480 MHz
- Producer: LumenRadio

### **Antenna** (for wireless DMX version only)

- Max. gain: 5dBi

### **Strobe**

- Strobe effect with variable speed (max. 20 flashes per second)
- Pre-programmed random strobe pulse-effects

### **Dimmer**

- Smooth 16-bit dimming from 0 - 100 %

### **Mounting**

- Via four mounting holes in the housing

### **Temperatures**

- Maximum ambient temperature: 40° C
- Maximum housing temperature: 60° C

### **Total heat dissipation**

- 443 BTU/h (calculated)

### **Dimensions (mm)**

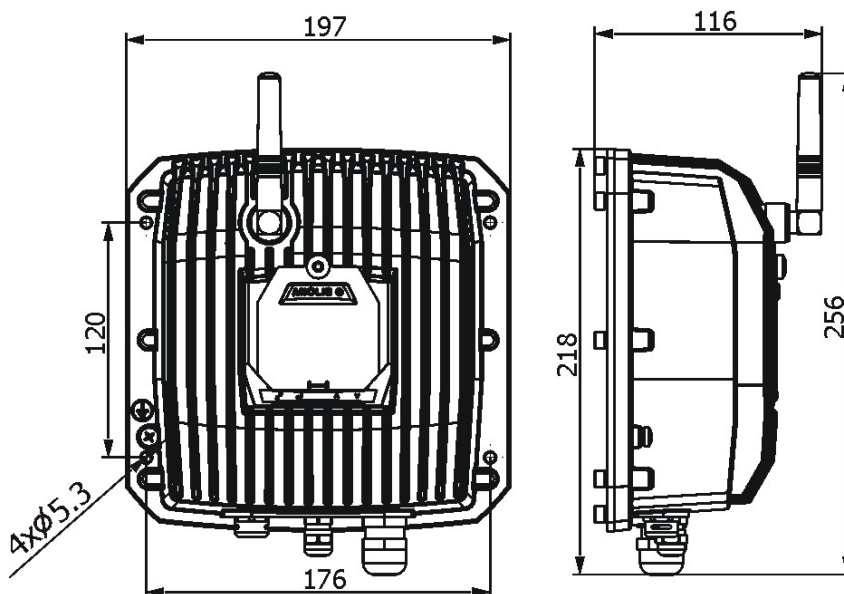

### **Weight**

- 4 kg



**Protection factor**

- **CE:** IP 67
- **US:** Suitable for wet location

**Connection**

- Data/power cable: Li9Y11Y 3xAWG16+2xAVG24 shielded and jacketed
- junction box
- connection between ArcPower 48 Outdoor and LED unit: LiYY 8xAWG22 UL Style 2517/CSA O.D. 6,70mm (length=0.6m) with connector CGRBDU-08BFFA (female)

**Note.** max. length of connection cable between the ArPower 48 Outdoor and the LED unit should not exceed 80m (at 350mA load) or 20m (at 700mA load).

**Included items**

- 1 x ArcPower 48 Outdoor
- 1x connector Chogori 08BMMA-SL8001 (male)
- 1 x Junction box
- 4 x reducing seal (P/N 13051388) - for diameter of cable 4-8mm
- 1 x User manual

## 11. Cleaning and maintenance

***DANGER !***  
***Disconnect from the mains before starting any cleaning or maintenance work***

Rinse off loose dirt with low pressure water spray. Wash the housing with a soft brush or sponge and a mild, non-abrasive washing detergent. Rinse it.

There are no serviceable parts inside the device.

Maintenance and service operations are only to be carried out by a qualified person.

Should you need any spare parts, please use genuine parts.

*Specifications are subject to change without notice.*

*October 2, 2017*