

QR code for Installations Instructions



The unit must be installed by a qualified electrician in accordance with all applicable regulations including local and national construction and electrical codes. This device falls under class I and must be grounded!



**STEP 1
 MOUNTING HOLE PREPARATION**

1A

Soft ground

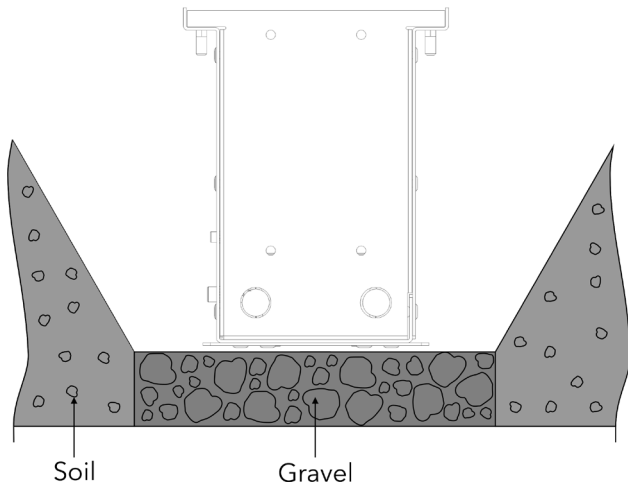

Soft ground mounting hole with gravel as drainage. (Minimum depth of gravel drainage is 300mm)

1B

Hard ground

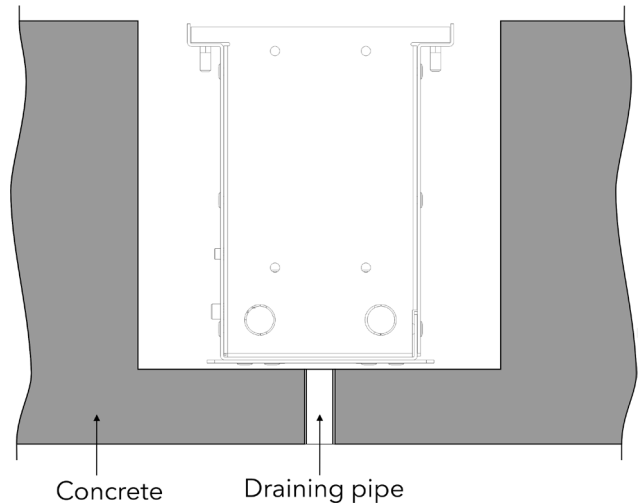

Hard ground mounting hole with draining pipe.

**STEP 2
 DRAINAGE TEST**

1A

Soft ground test drainage

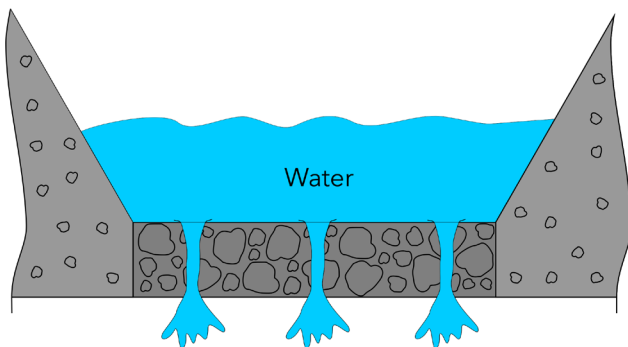

Drainage of mounting hole in soft surface via gravel drainage.

1B

Hard ground test drainage

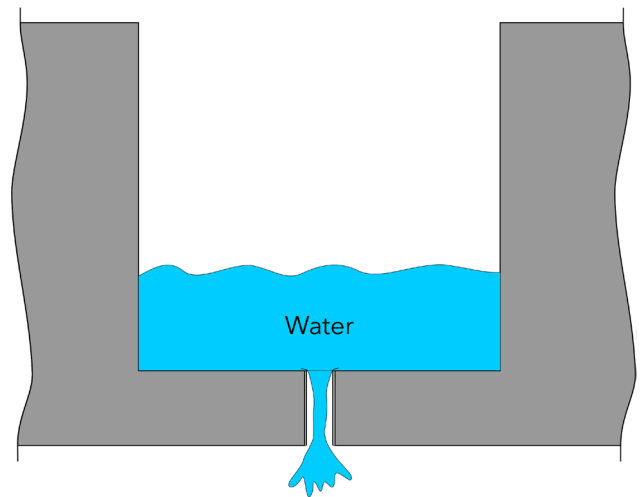

Drainage of mounting hole in hard surface via draining pipe.



Perform test by filling mounting hole with water. Water must drain away within 30 minutes.



Drainage Test

	WATER VOLUME	DRAINAGE RATE
Eminere 1	14 l	14l/30 min.
Eminere 2	20 l	20 l/30 min.
Eminere 4	35 l	35 l/30 min.

**STEP 3
MOUNTING SLEEVE INSTALLATION**

1 6X M5x10

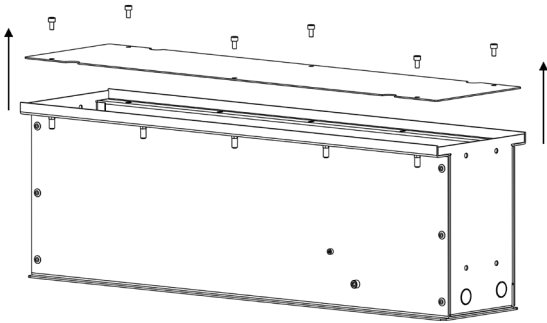

Unscrew six M5x10 bolts and remove the Temporary Cover from Mounting Sleeve.

3 2X M4x14

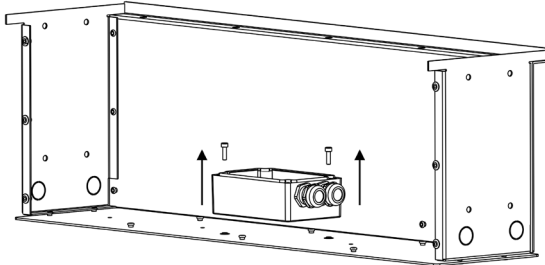

Unscrew two M4x14 screws and release the Junction Box from the Mounting Sleeve for easier access to connection terminals.

5 Conduit intallation (scope of others)

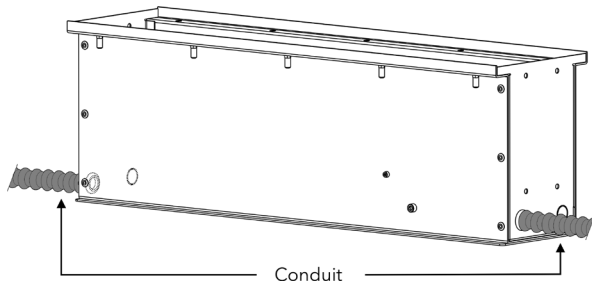

! The power/data cable to and from the mounting sleeve must be placed in a conduit **!**

7 HEAD2HEAD grounding of Mounting Sleeves

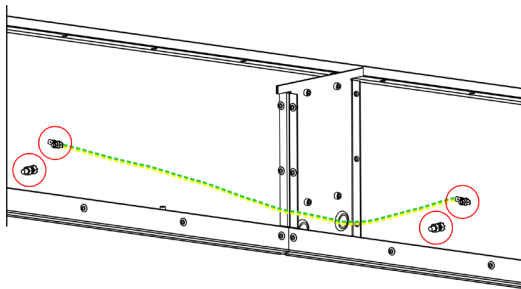

It is necessary to make grounding between sleeves. Connect wire either to faston terminal or by screw.

2 4X M4x20

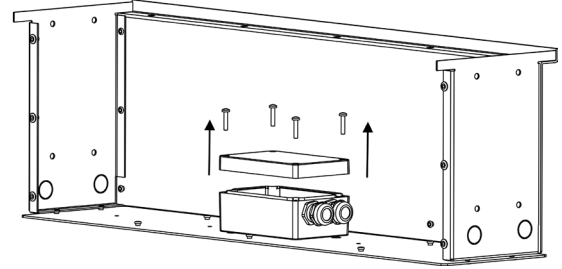

Unscrew four M4x20 screws and remove the Cover of Junction Box.

4

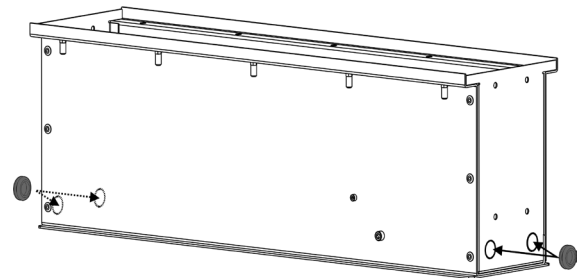

Push through pre-cut holes (diameter 20mm) for cables and insert protective Rubber Grommets into them.

6 HEAD2HEAD connection of Mounting Sleeves

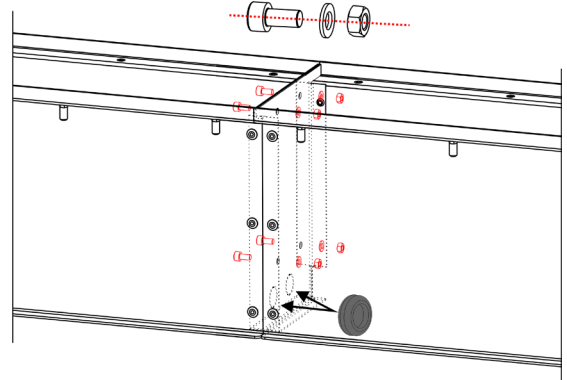

Push through pre-cut holes (diameter 20mm) for cables in both Mounting Sleeves and fasten them together with four screws M5x10, washers and nuts (as illustrated). Insert two protective Rubber Grommets into the cable openings of joined Mounting Sleeves.

8

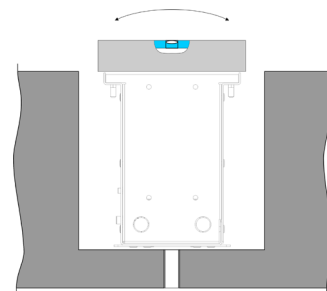

Insert the Mounting Sleeve into the mounting hole and level it using spirit level.

9 Mounting of Mounting Sleeve to the surface

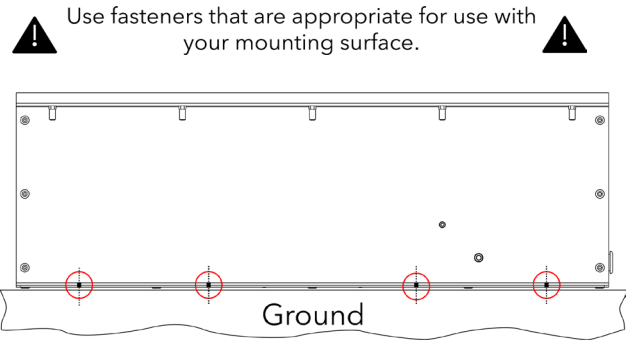
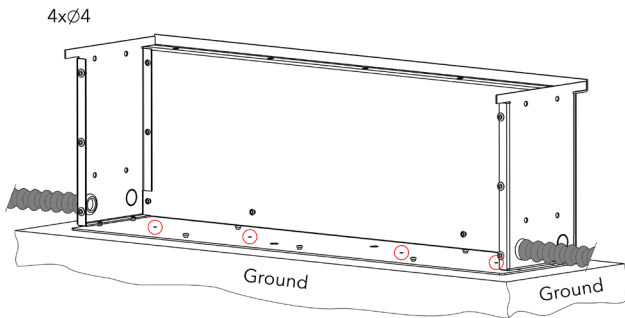

Fasten the Mounting Sleeve to the surface with four suitable fasteners via four holes with diameter of 4mm (highlighted in a picture).

STEP 4
CONNECTION

1

! Junction box must be positioned into the mounting sleeve in correct orientation. Side with 1 input facing the previous Eminere Inground/E-box and side with 2 outputs facing the following Eminere Inground. As illustrated on picture below. !

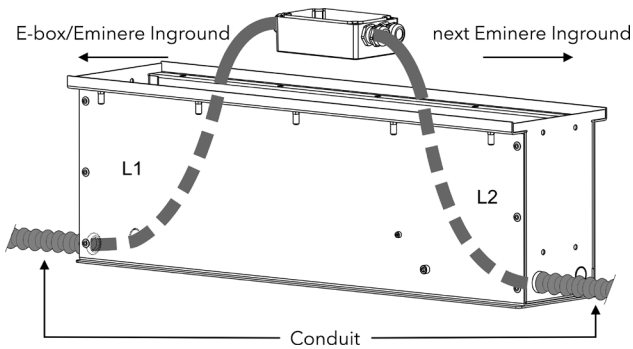

Connect the power/data cable with cable glands of Junction Box. See recommended cable lengths below.

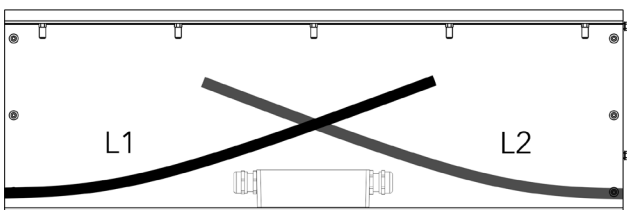

Recommended cable length

	CABLE LENGTH L1	CABLE LENGTH L2
Eminere 1	25 cm	55 cm
Eminere 2	40 cm	55 cm
Eminere 4	65 cm	85 cm

2

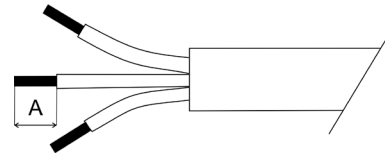

A	
Power Connection	9mm
Data Connection	9mm

Strip these lengths for cable connections.

3 Connection – colour coding

Wiring of the Eminere Cable - CE Leader

WIRE	POWER CONNECTION	WIRE	DATA CONNECTION
Brown	L	Orange	Data - (D-)
Blue	N	Purple	Data + (D+)
Green	Ground	Shielding	Data Ground (0V)

Wiring of the Eminere Cable - US Leader

WIRE	POWER CONNECTION	WIRE	DATA CONNECTION
Black	L	Orange	Data - (D-)
White	N	Red	Data + (D+)
Green	Ground	Shielding	Data Ground (0V)

4 Wiring connection

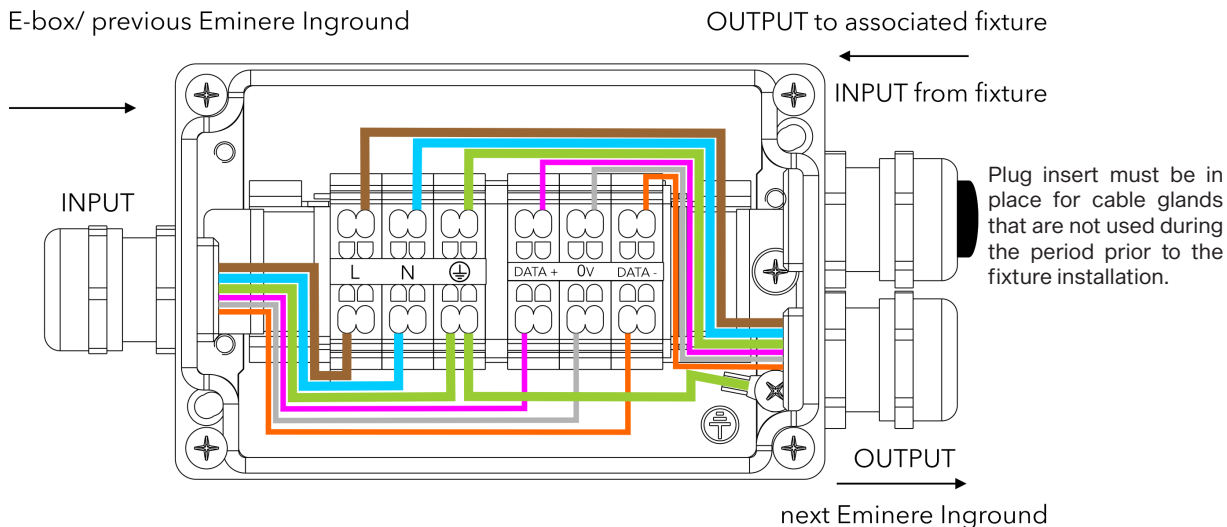

For Data and Power - EU color code shown

**STEP 5
CABLE GLAND INSTALLATION**

Put cable thru cable gland M20x1.5 and connect into connection terminal. Assemble cable gland as shown below. Use wrench size 24 for cable gland M20x1.5

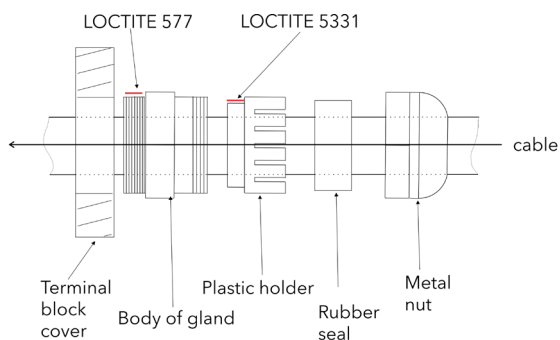

Apply Loctite 5331 thread sealant on the plastic holder and Loctite 577 thread locking compound on the gland body prior to assembly in the indicated locations.

Failure to properly install cable glands will result in failure of the water tight seal!

**STEP 6
REASSEMBLING OF JUNCTION BOX AND MOUNTING SLEEVE**

1

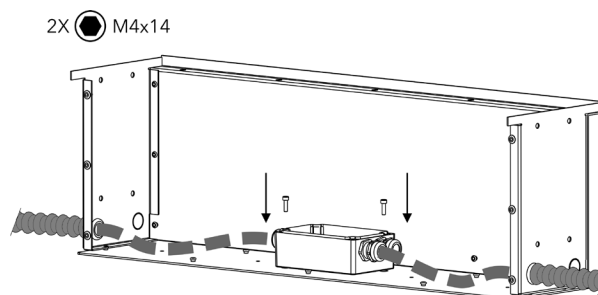

Mount the Junction Box back to Mounting Sleeve and fasten it by two M4x14 screws.

2 4X ⊕ 2 Nm

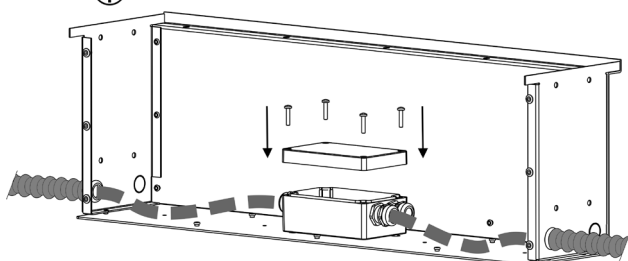

Put back the gasket of Junction Box, if it was removed. Connect the grounding wire to the junction box Cover and put the Cover back on Junction Box. Make sure that thread is clean and functional. Fasten the cover with four M4x20 screws.

3 6X M5x10

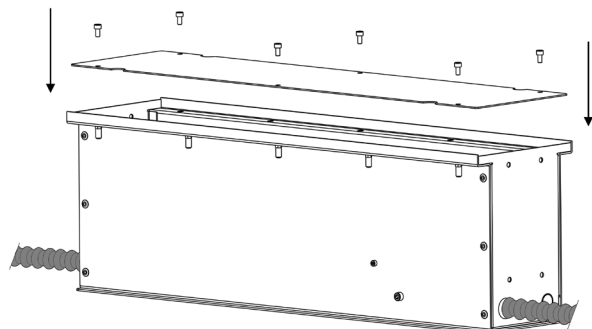

Insert Temporary Cover back into Mounting Sleeve and fasten it with six M5x10 bolts.

STEP 7
FILLING OF SURFACE MOUNTING HOLE

1A

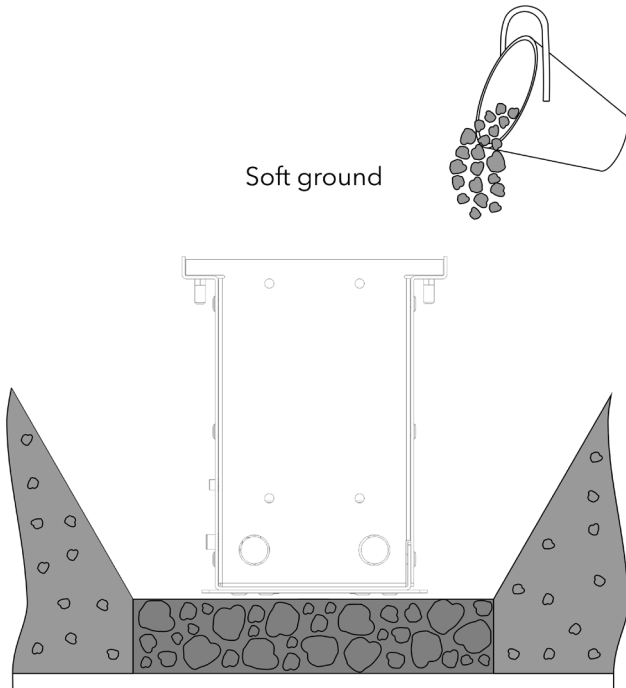

Mounting hole can be filled up with soil or gravel. Filling material must not obstruct the drainage.

1B

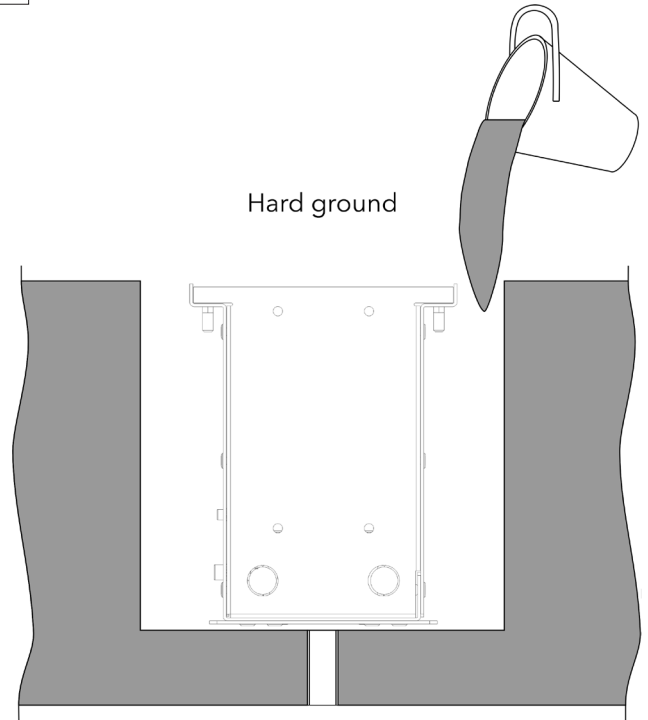

Mounting hole can be filled up with concrete, soil or gravel. Filling material must not obstruct the drainage.

2A

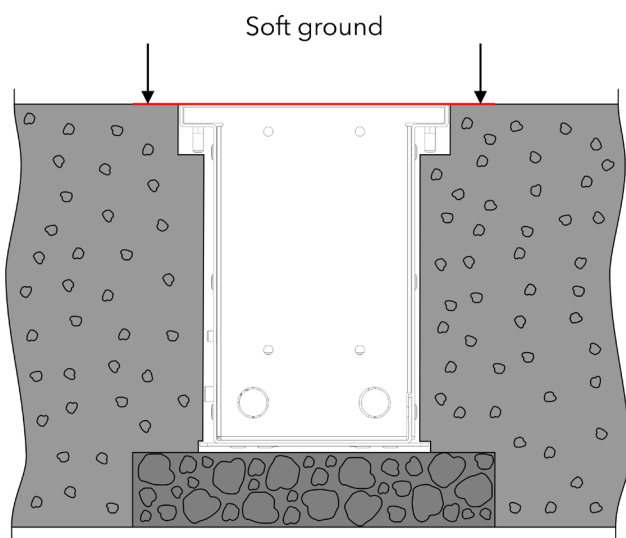

2B

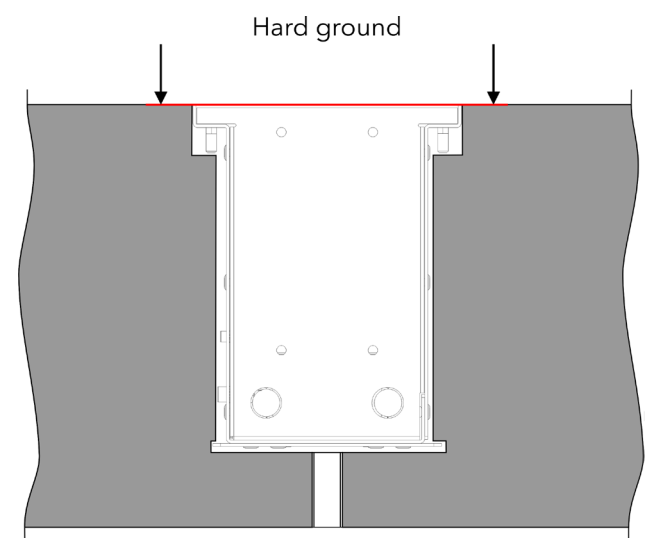

Filling material should be in same level with the top of Mounting Sleeve.