

ArcControl DU

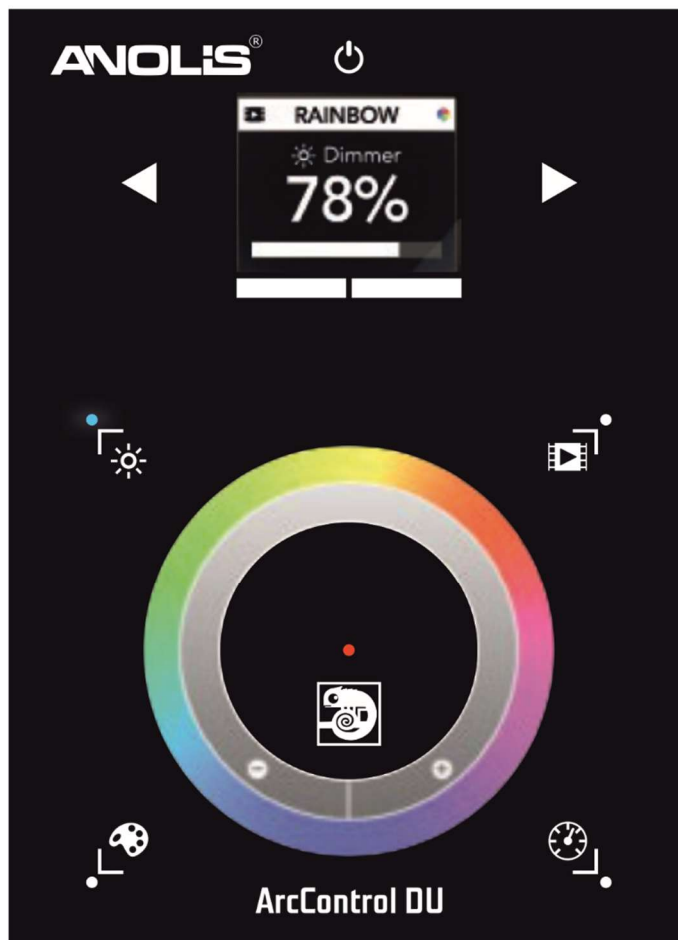

QR code for user manual



Table of contents

1. Features	3
2. Installation	3
3. Connections and hardware operation.....	5
4. Setting up the Controller	7
4.1 iPhone/iPad/Android Control.....	7
4.2 Programming the Controller.....	7
4.3 Color Temperature Mixing.....	7
4.4 Settings Menu.....	7
4.5 Service.....	8
5. Internal Menu	8
6. Troubleshooting.....	11
7. Technical specifications	12

1. Features

- Sleek glass design which sits 11 mm from the wall
- Graphical color display to show selected environment
- Color/dimmer/speed palette
- Color temperature mixing
- Touch sensitive buttons. No mechanical parts
- Touch sensitive wheel allows for accurate color selection
- Multi-zone microSD memory
- Multi-room control with 500 scenes, 10 zones
- 1024 DMX channels. Control 340 RGB fixtures
- USB & Ethernet connectivity for programming and control
- RS232, Dry Contact Ports and an Infra Red input port
- Clock and calendar with Sunrise/Sunset triggering
- Network communication. Control lighting remotely
- Catalog of designs including black and white glass
- OEM customization of the color palette and logo
- Windows/Mac software to set dynamic colors/effects
- iPhone/iPad/Android remote and programming apps

2. Installation

1. Mount an electrical box inside the wall

The controller can be installed in any standard electrical backbox. If you use a double size box, you can insert the power supply inside.

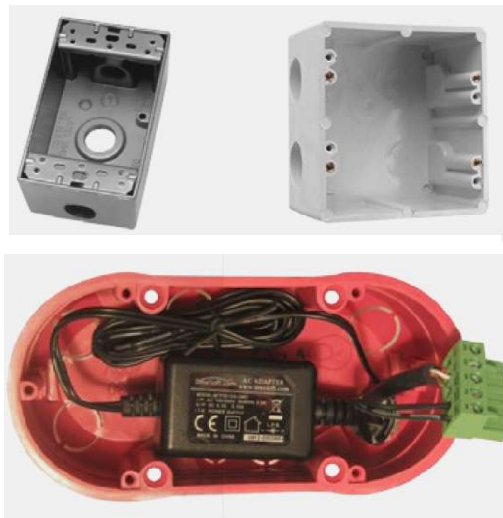

2. Connect the wires

POWER: Connect a 6V to 7V DC 0.6A ACDC supply. Be sure to not invert the + and the ground.

DMX: Connect the DMX cable to the lighting receivers (Leds, Dimmers, Fixtures..) (for XLR: 1=ground 2=dmx- 3=dmx+)



3. Mount the interface on the wall

First, mount the back side of the interface on the wall with 2 or more screws

Secondly, plug the connectors:

- DMX and power (connector block or RJ45)
- Ethernet cable

The front panel is mounted by pressing it against the back plate and then sliding down. 2 screws should then be attached underneath to hold the controller in place.



POWER+DMX WITH THE CONNECTOR BLOCK



POWER+DMX WITH THE RJ45 CABLE

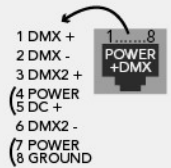

CHECK PIN CONFIGURATIONS. APPLYING POWER TO THE DMX INPUT WILL DAMAGE THE CONTROLLER. MAKE SURE THE CONTROLLER IS MOUNTED WITHOUT TOO MUCH FORCE BEHIND AS THIS CAN PUSH APART THE GLASS.

2x10 pins EXTENSION socket

DMX CHIP replacement

DMX universe #1

DMX universe #2

Ref: SP485ECN-L
MAX485 CSA



EXTENSION socket

VIN	20	19	PORT1
GND	18	17	PORT2
IR_RX	16	15	PORT3
3.3V	14	13	PORT4
Relay	12	11	PORT5
DMX2+	10	9	PORT6
DMX2-	8	7	PORT7
DMX1+	6	5	PORT8
DMX1-	4	3	RS232 RX
GND_DMX	2	1	RS232 TX

Compatible header connectors:

- WURTH ELEKTRONIK ref: 61301021121
- MOLEX ref: 10-89-7202
- TE Connectivity ref: 1-87227-0
- FCI ref: 77313-101-20LF
- HARWIN ref: M20-9981046
- SAMTEC ref: TSW-110-xx-T-D
- FARNELL ref: 1841232
- RS ref: 763-6754 673-7534 251-8165
- MOUSER ref: 538-10-89-7202
- DIGIKEY ref: WM26820-ND

3. Connections and hardware operation

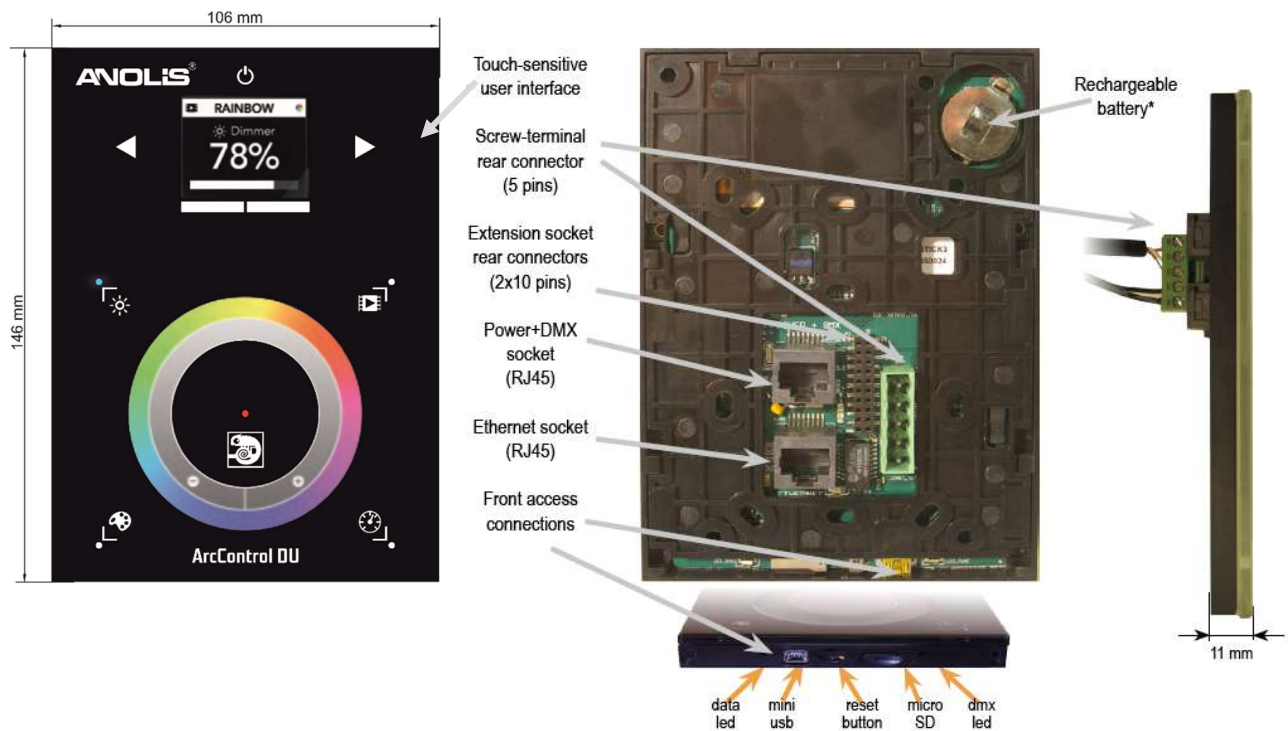

Dry Contact Port Triggering

It is possible to start scenes using the input ports (contact closure). To activate a port, a brief contact of at least 1/25 second must be established between the ports (1...8) and the ground (GND).

Note: the scene will not be switched off when the switch is released.

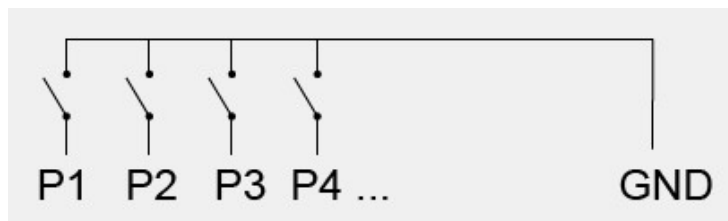

RS232 Triggering

Make a cable using the 3 pins: TX, RX and G (GND)

Set the RS232 parameters to: 9600bds 8 bits, no Parity, 2 Stop bits

Messages should be hexadecimal not decimal (ie. 1 = 01, 255 = ff etc.)

- To play a scene, send 4 bytes: 1 x y 255
- To stop a scene, send 4 bytes: 2 x y 255
- To pause a scene, send 4 bytes: 3 x y 255
- To release a pause, send 4 bytes: 4 x y 255
- To reset a scene, send 4 bytes: 5 x y 255

When (y)=0, (x) can be set between 0 and 255

-to stop scene 145, send the command: 2 145 0 255

When (y)=1, (x) can be set between 0 and 243 to trigger scenes 256-499

-to play scene 300, send the command: 1 44 1 255

BLACKOUT Relay (energy saving)

A relay can be connected between the RELAY and GND sockets of the 20 pin extension socket. This can be used to turn off other equipment such as lighting drivers. The signal is connected when the controller is in standby.

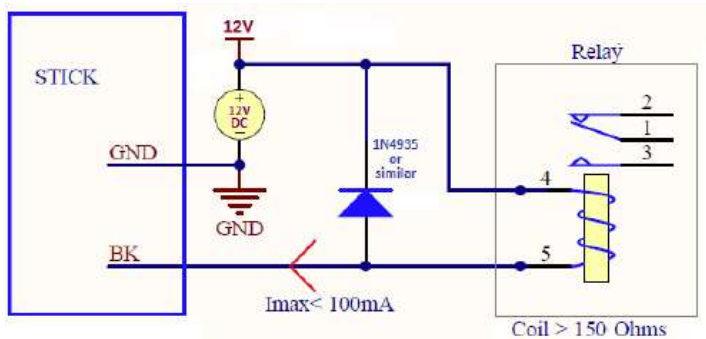

Example of relay :
FINDER Ref.
22.23.9.012.4000

Infra Red

The controller works with the official IR remote control, however there is no receiver. A 36khz infra red receiver can be connected, such as the TSOP34836 by Vishay Semiconductors. Farnell ref: 4913127. This can be attached to the 20 pin connector. It's a good idea to add a resistor and capacitor to surpress power supply disturbance.

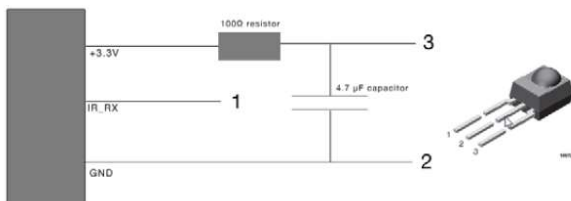

Network Control

The controller can be connected to a local network, allowing it to be controlled from a smartphone or tablet over WiFi.

- Connect the controller to a router or switch with an RJ45 cable
- The controller is set by default to get an IP address from the router via DHCP. If the network is not working with DHCP, a manual IP address and subnet mask can be set using the Hardware Manager
- If the network has a firewall enabled, allow ports 2430 and 2431

TCP Triggering

The controller can be connected to an existing automation system over a network and triggered via TCP packets on port 2431 or UDP packets on 2430. Refer to the remote protocol document for more information.

4. Setting up the Controller

4.1 iPhone/iPad/Android Control

The controller can be used with one of 3 different apps. Each available at Google Play and the App store.

DMX Lightpad 3

Designed to work seamlessly with the controller, DMX Lightpad 3 provides an easy way to control your lights over a local WiFi network. Use the wheel to change the dimmer, color or speed, and the arrows to select scenes and effects just like the wall panel. Swipe down to reveal quick access scene selection buttons.

Easy Remote

Create an entirely customized remote controller for your tablet or smartphone. Easy Remote is a powerful and intuitive app allowing you to easily add buttons, faders, color wheels and more. Connect to a WiFi network and the app will find all compatible devices.

Arcolis

The Arcolis application is a comprehensive tool allowing you to directly control and re-program the controller from your smartphone or tablet. This is a simple application which can be used by just about everyone in any situation. Mobile, easy to use and powerful, Arcolis is the ideal controller for dimming or switching traditional, LED and RGB color mixing DMX lighting fixtures. Program static and dynamic lighting scenes and effects. Arcolis is compatible with Android devices only.

4.2 Programming the Controller

The controller can be programmed from a PC, Mac, Tablet or Smartphone using the software available on our website.

Refer to the corresponding software manual for more information. The firmware can be updated using the Hardware Manager which is included with the programming software.

ESA Pro Software (Windows) - Timeline + Multi-Zone

ESA2 Software (Windows/Mac) - Single Zone

Hardware Manager (Windows/Mac) - Firmware, clock..

4.3 Color Temperature Mixing

In addition to mixing RGB using the color pallet, it's also possible to mix up to 3 custom colors. This is useful for mixing color temperature. To set this up, choose the correct profile for your lighting fixture when programming the controller.

Profiles for common channel configurations can be found in the 'Generic' folder:

RGBW for Red, Green, Blue, White

RGBA for Red, Green, Blue, Amber

RGBY for Red, Green, Blue, Yellow

WWCW for Warm White, Cold White

Once your show has been written to the controller, tap the color mode button and use the circular palette to change the color. If your lighting fixture has more than 3 color channels, tap the color mode button a second time to mix the additional colors

4.4 Settings Menu

To access the settings menu, hold the standby button for 3 seconds.

- Use the arrow buttons or palette to scroll through the menus
- Use the area buttons to navigate forwards and backwards
- The 'undo' button can also be used to navigate forwards

Mode (M): Manages the on/off button and the 4 modes (dimmer, speed, color, scene)

Arrows (A): Allows you to adjust which modes can be controlled by the arrows

Pallet (P): Allows you to adjust which modes can be controlled by the palette wheel

Scene (S): Scene management

First Start (F): Default settings when the unit is first powered up

Trigger (T): Manages the controllers external triggering properties

Ethernet (E): Enables the Ethernet socket on the controller

Date/Time (D): Manages the date and time stored inside the controller

Graphics (G): Screen management

DMX Output (X): Manage the timings of the DMX output messages and the page priorities (advanced function!)

Sensitive (S): Manage the touch sensitivity settings

Language (L): change the language of the text which appears on the screen

About: check the firmware release date and version number and assign a name for the controller



4.5 Service

Servicable parts include:

- Memory card - used to store the scenes
- Battery - used to store the clock/calendar
- DMX Chips - used to drive the DMX

To replace the Li-Ion rechargeable battery on the ArcControl DU:

1. You need a rechargeable 3.6v LIR 2032 replacement battery
2. Remove the back panel by pulling down and sliding it out.
3. Using a paper clip push the battery from the bottom so it slides out of its cage.
4. Slide the replacement battery in from the top, making sure the positive side is facing up.
5. Replace the back panel by pushing it up into place.

5. Internal Menu

MODE (M) : Manages the on/off button and the 4 modes (dimmer, speed, color, scene)

M OFF enable : enables/disables the use of the on/off button so that the controller is permanently on

M Dimm. enable : when enabled, scenes can be made brighter or darker

M Color. enable : when enabled, the color of a scene can be changed

M Speed. enable : when enabled, dynamic scenes can be made faster and slower

M Scene. enable : when enabled, the scene can be changed

M Auto mode : when enabled, the controller will revert to the default mode after it has been left for a specified period of time

M Auto time : the amount of time the controller will wait before reverting to the default mode

M Default : the default mode which the controller will revert to after a certain amount of time

M Dimmer 100% : when enabled, the dimmer mode will adjust between 0% and 100% without saturating to white between 100% and 200%

M Lock Control : Once this is enabled, you can hold the dimmer button for 5 seconds to enable/disable lock mode. It's automatically activated after 120 seconds. When lock is activated, you'll see a red border around the screen

Arrows (A) : Allows you to adjust which modes can be controlled by the arrows

A Dimmer enable : allows for the Dimmer mode to be controlled by the arrows

A Color enable : allows for the Color mode to be controlled by the arrows

A Speed enable : allows for the Speed mode to be controlled by the arrows

A Scene enable : allows for the Scene mode to be controlled by the arrows

A Default : the mode to jump to when the arrows are pressed, if the arrows are not enabled on the selected mode

Pallet (P) : Allows you to adjust which modes can be controlled by the palette wheel

P Dimmer enable : allows for the Dimmer mode to be controlled by the palette wheel

P Color enable : allows for the Color mode to be controlled by the palette wheel

P Speed enable : allows for the Speed mode to be controlled by the palette wheel

P Scene enable : allows for the Scene mode to be controlled by the palette wheel

P Default : the mode to jump to when the palette is pressed, if the palette is not enabled on the selected mode.

Scene (S) : Scene management

S 0(off) enable : displays an empty off scene before scene 0 in each area

S Pause enable : allows a scene to be paused if the scene mode button is held for 1 second

S Stop enable : allows a scene to be stopped if the scene mode button is held for 4 seconds

S Fade config : manages fading between scenes

From Show : the fade time set inside the show file will be used

Force : the automatic fade time set in the menu will override all fadetimes in the show file

Force Max : the controller will look at the show file fade time and the menu fade time and use the greatest

Force Min : the controller will look at the show file fade time and the menu fade time and use the smallest

Never : the controller will never fade between scenes

S Fade time : the time of the automatic fade between scenes

S Setting management : determines how dimmer/speed/color overrides are saved

SaveAlways : the dimmer/speed/color overrides all scenes until the reset button has been pressed

NeverSave : the dimmer/speed/color is never saved

AutoReset : the dimmer/speed/color is saved on the current scene

S Trigger : sets the scene triggering mode. Time Delay and Scene Butt allow for scenes to be scrolled through without playing

Auto : the scene will be triggered as soon as it's selected

Time Delay : a short delay is added before a scene is triggered

Scene Butt. : the selected scene will not play until the scene button is pressed

First Start (F) : Default settings when the unit is first started

F Scene Nr. : specify a default startup scene. 'Scene Star' mode must be enabled in the Scene Mode options (below)

F Start Scene Mode : manages the startup mode for scene selection

Scene Star : activates a specific scene at startup. The scene number is set in the F Scene Nr. option (above)

Recovery : activates the previous calendar/time triggered scene. Useful for recovering from power interruptions

Off : activates the off scene

F Display Time : when enabled, the time will be displayed on the screen at startup

F Display Firm : when enabled, the firmware version will be displayed on the screen at startup

F Start Trigger : when enabled, in combination with Recovery mode, a calendar triggered scene will start from where it was last playing, after a power interruption. When disabled, a scene will start at the beginning.

Trigger (T) : Manages the controllers external triggering properties

T Time enable : enables the clock triggering

T Ports enable : enables the 8 dry contact ports

T RS232 enable : enables scene triggering by RS232

T IR enable : enables the infra red port (disabled by default to prevent interference)

T UDP enable : allows the controller to send and receive UDP messages required for network control

T Blackout port : enables the blackout relay output which is triggered when the standby button is touched

Ethernet (E) : Manages the controller's network settings

Ethernet : Enables the Ethernet socket on the controller

Dynamic IP Addr : enables dynamic IP addressing (DHCP) which allows the controller to obtain an IP address from a router

Sync Blackout: when this option is enabled, all other controllers on the network will go into standby when the standby button is pressed

Enable NTP : enables Network Time Protocol. The controller will synchronize the clock with the internet if a connection is available

Ethernet : enable ethernet

Dynamic IP Add : If enabled, the controller will look for a DHCP server to receive network settings

Sync Blackout : synchronizes blackout mode across all controllers on a network

Enable NTP : enables time synchronization over the internet

NTP Server : the IP address of the server to synchronize the clock. The default is 005.135.141.108

DHCP Status: shows whether DHCP has assigned a valid IP address. DHCP success or fail displayed

Device's IP Add : the controller's static IP address that it will use if it does not receive an IP address via DHCP

Lease : the lease time for an IP address given by DHCP

Mask: the subnet mask of the controller if not set to DHCP. Generally this is 255.255.255.0

Default Gateway : the IP address of the router if not set to DHCP

MAC Address : a unique ID used to identify the controller on the network

Date/Time (D) : Manages the date and time stored inside the controller

Date : the controllers date

Time : the controllers clock time

G Bright normal : the % brightness when the controller is not sleeping
G Bright sleep: the % brightness when the controller is sleeping

G Bright LED : the % brightness of the mode and reset LEDs

Graphics (G) : Screen management

G Image enable : allows for images to be shown for each scene if they have been assigned in the programming software

G Image full : when enabled, the image will be displayed in full screen and the scene and area will not be visible

G Image time : the time it takes before the image is displayed in full screen

G Sleep enable : when enabled, the screen brightness will dim after a certain amount of time

G Sleep time : the amount of time to wait before sleeping

G Bright normal : the brightness of the screen's backlight

G Bright sleep : the brightness of the screen's backlight whilst the controller is sleeping

G Bright LED : the brightness of the scene, undo and standby LED's

DMX Output (X) : Manage the timings of the DMX output messages and the page priorities (advanced function!)

X MBB : Mark Before Break- the time to wait between sending each 512 channel DMX message (or 'packet')

X Break : Break- the time to wait just before sending a new packet, resetting the DMX line

X MAB : Mark After Break- the message which tells your receiver to begin reading data

X MBS : Mark Between Slots- the delay time between sending each DMX channels data within the DMX packet

Univ-1/Univ-2 : each timing can be set differently depending on the universe number

X Alphan Mode : if the same scene is triggered in the global area and a second area, the area with the highest letter will take priority

X LTP Mode : If the same scene is triggered in the global area and a second area, the latest scene triggered takes priority

Sensitive (S) : Manage the touch sensitivity settings

S USB Init : reset the touch sensitivity when the USB is connected and disconnected

S Auto Time : the time to wait before automatically resetting the touch sensitivity

S High Sense : when enabled, the sensitivity will be increased

S See Values : see each touch sensitive button number and palette value

Language (L) : change the language of the text which appears on the screen

About : check the firmware release date and version number and assign a name for the controller

Reset : Reset all settings to the factory default

6. Troubleshooting

The 4 Mode LEDs on the controller are flickering

The controller is in bootloader mode. This is a special 'startup mode' which is run before the main firmware loads.

- Check that there is nothing metallic touching the back of the controller
- Try re-writing the firmware with the latest hardware manager
- Try formatting or replacing the SD card

All LEDs on the controller are flickering

There has been no showfile detected on the SD memory card.

- Try formatting the SD card in the computer
- Try re-writing the show file
- Try replacing the SD memory card

All LEDs on the controller are flickering except the standby LED

There is no SD card detected.

- Check the SD card is properly connected
- Check the SD card is 32Gb or less in size
- Try formatting the SD card to FAT16 or FAT32 in the computer
- Try re-writing the show file
- Try replacing the SD memory card

The lights are not responding

- Check the DMX +, - and GND are connected correctly
- Check that the driver or lighting fixture is in DMX mode
- Be sure that the DMX address has been set correctly
- Check there are no more than 32 devices in the chain
- Check that the DMX LED is flickering to the right of the SD card

- Connect with the computer and open Hardware Manager (found in the software directory). Open the DMX Input/Output tab and move the faders. If your fixtures respond here, it is possibly a problem with the show file.

The controller is not detected by the computer

- Be sure that the latest software version is installed
- Connect by USB and open the Hardware Manager (found in the software directory). If it's detected here, try to update the firmware

7. Technical specifications

Input Power: 6-7V DC 0.6A

Output Protocol: DMX512 (x2)

Programmability: PC, Mac, Tablet

Connections: USB, Ethernet, RS232, Clock, 8 dry contact ports, 5V output relay

Memory: microSD (32Gb Max)

Temperature: -10 °C - 45 °C

Mounting: Single or double-gang wall socket

Dimensions: 146x106x11mm

Weight: 247g

Standards: EC, EMC, ROHS, ETL

Package: ArcControl SU, USB stick with software, USB cable, connector block

Optional accessories: DC power supply (P/N. 1305 1648)

Specifications are subject to change without notice.

May 30, 2022